

<http://www.ebaman.com>
TEKTRONIX®

**7L5
SPECTRUM ANALYZER
OPTIONS**

INSTRUCTION MANUAL

Tektronix, Inc.
P.O. Box 500
Beaverton, Oregon 97077

Serial Number _____

070-2155-03

FIRST PRINTING OCT 1976

WARRANTY

This Tektronix product is warranted against defective materials and workmanship, under normal use, for a period of one year from date of initial shipment. Tektronix will repair or replace, at its option, those products determined to be defective within the warranty period and returned, freight prepaid, to a Tektronix Service Center. There is no implied warranty for fitness of purpose.

Please direct all requests for service or replacement parts to the nearest Tektronix Service Center or Field Office; include the type or part number of the product and its serial number.

Copyright © 1976, 1977, 1978 by Tektronix, Inc. All rights reserved. Contents of this publication may not be reproduced in any form without the permission of Tektronix, Inc.

Products of Tektronix, Inc. and its subsidiaries are covered by U.S. and foreign patents and/or pending patents.

TEKTRONIX, TEK, SCOPE-MOBILE, TELEEQUIPMENT, and  are registered trademarks of Tektronix, Inc.

Printed in U.S.A. Specification and price change privileges are reserved.

GENERAL INFORMATION

INTRODUCTION

This manual contains documentation for the 7L5 Spectrum Analyzer Options. Each is a complete and separate section or supplement to the manual. Changes and corrective information are added, at the back of the manual. This information is incorporated into the respective manual text and diagrams when the option section is reprinted. History information is included with the updated data. Original pages are identified by the symbol @, revised pages by a revision date on the lower inside corner of the page. These options add an assembly, with its part number; to the 7L5 instrument. The suffix portion of the part number signifies updating process of the assembly. Up-dated manual supplements may contain information that is not applicable to your instrument; however as previously stated, the manual does contain history information.

Depending on the production model of the 7L5, it may be impractical to field install some option assemblies. Contact your local Tektronix Field Office or representative for information.

INSTALLATION AND REPACKAGING

Initial Inspection

The instrument was inspected both mechanically and electrically before shipment. It should be free of marks or scratches and electrically meet or exceed all specifications. To confirm this, inspect the instrument for physical damage that may have occurred in transit and test the electrical performance by following the Operating Instructions and Performance Check Procedure in the section applicable to the Option. If there is damage, or if the instrument does not perform, contact your local Tektronix Field Office or representative.

Installation

These options are normally shipped attached to the 7L5 and ready to plug into the 7000-Series mainframe. If the option is shipped as a field modification kit, instructions on how it is installed to the 7L5 will be included with the kit. After installation, plug the 7L5 with option into a 7000-Series mainframe, and proceed as directed in the Operations section of this manual. (Both Options 25 and 21 require a mainframe with readout.)

Repackaging for Shipment

If a Tektronix instrument is to be shipped to a Tektronix Service Center for service or replacement, attach a tag showing, owner (with address) and the name of an individual at your firm that can be contacted. Include complete instrument serial number and a description of the service required.

Save for re-use the shipping container your instrument was shipped in. If the original packaging is not available, or is unfit for use, repackage as follows:

1. Obtain a shipping container made of heavy corrugated cardboard or wood with inside dimensions of no less than six inches more than the instrument dimensions; this will allow room for cushioning. Refer to Table 1 for carton test strength requirements.
2. Wrap the instrument in heavy paper or polyethylene sheeting. Protect the front panel with urethane foam or cardboard strips.
3. Cushion the instrument on all sides by tightly packing dunnage or urethane foam between the carton and the instrument allowing three inches on all sides.
4. Seal the carton with shipping tape or an industrial stapler.

TABLE 1

Gross Weight (lb)	Carton Test Strength (lb)
10-30	275
30-100	375
120-140	500
140-160	600

If you have any questions, contact your local Tektronix Field Office or representative.

7L5 OPTION 21

Log Sweep

General Information

The 7L5 Option 21 provides the additional feature of an IRIG logarithmic frequency span (250 Hz to 222 kHz) display. Because the display is generated from three sweeps, covering a decade of frequency each, digital storage memory operation is used. Resolution and sweep time are automatically controlled to provide an amplitude calibrated display for the data acquisition time. Signal acquisition time for one display is no more than 2.5 seconds. A Sweep Inhibit feature will store and display any full span log display until SWP INHIBIT is switched off. This is equivalent to single sweep operation.

An IRIG graticule overlay is provided as a standard accessory. The graticule can be inserted over the face of the crt behind the crt bezel. The following table lists proportional bandwidth subcarrier channels.

**IRIG PROPORTIONAL BANDWIDTH
SUBCARRIER CHANNELS**

CHANNEL	LOWER LIMIT (CPS)	CENTER FREQ (CPS)	UPPER LIMIT (CPS)	BAND WIDTH (CPS)
1	370	400	430	60
2	518	560	602	84
3	675	730	785	110
4	888	960	1,032	144
5	1,202	1,300	1,398	196
6	1,572	1,700	1,828	256
7	2,127	2,300	2,473	346
8	2,775	3,000	3,225	450
9	3,607	3,900	4,193	586
10	4,995	5,400	5,805	810
11	6,799	7,350	7,901	1,102
12	9,712	10,500	11,288	1,576
13	13,412	14,500	15,588	2,176
14	20,350	22,000	23,650	3,300
15	27,750	30,000	32,250	4,500
16	37,000	40,000	43,000	6,000
17	48,560	52,500	56,440	7,880
18	64,750	70,000	75,250	10,500
19	86,025	93,000	99,975	13,950
20	114,700	124,000	133,300	18,600
21	152,625	165,000	177,375	24,750

TABLE OF CONTENTS

SECTION 1	SPECIFICATIONS	Page
	Electrical Characteristics	1-1
	Environmental Characteristics	1-1
	Accessories	1-1
SECTION 2	OPERATING AND PERFORMANCE CHECK INSTRUCTIONS	
	Introduction	2-1
	Function of Controls and Connectors	2-1
	Operational Check	
	1. Preliminary Preparation	
	2. Check Frequency Range and Display Flatness	
	3. Verify Sweep Inhibit Operation	
WARNING		
<p><i>THE FOLLOWING SERVICING INSTRUCTIONS ARE FOR USE BY QUALIFIED PERSONNEL ONLY. TO AVOID PERSONAL INJURY, DO NOT PERFORM ANY SERVICING OTHER THAN THAT CONTAINED IN OPERATING INSTRUCTIONS UNLESS YOU ARE QUALIFIED TO DO SO.</i></p>		
SECTION 3	CALIBRATION	
	Equipment Required	3-1
	1. Preliminary Preparation	
	2. Calibrate the Sweep Span to 10 kHz	
	3. Calibrate the Log Sweep	
	4. Calibrate Resolution Bandwidth	
SECTION 4	CIRCUIT DESCRIPTION	
	General	4-1
	Detailed Description	
SECTION 5	MAINTENANCE INSTRUCTIONS	
	Introduction	
	Preparing the Instrument for Service	
	Replacing the Assembly	
SECTION 6	REPLACEABLE ELECTRICAL PARTS	
SECTION 7	DIAGRAMS	
SECTION 8	REPLACEABLE MECHANICAL PARTS	
CHANGE INFORMATION		

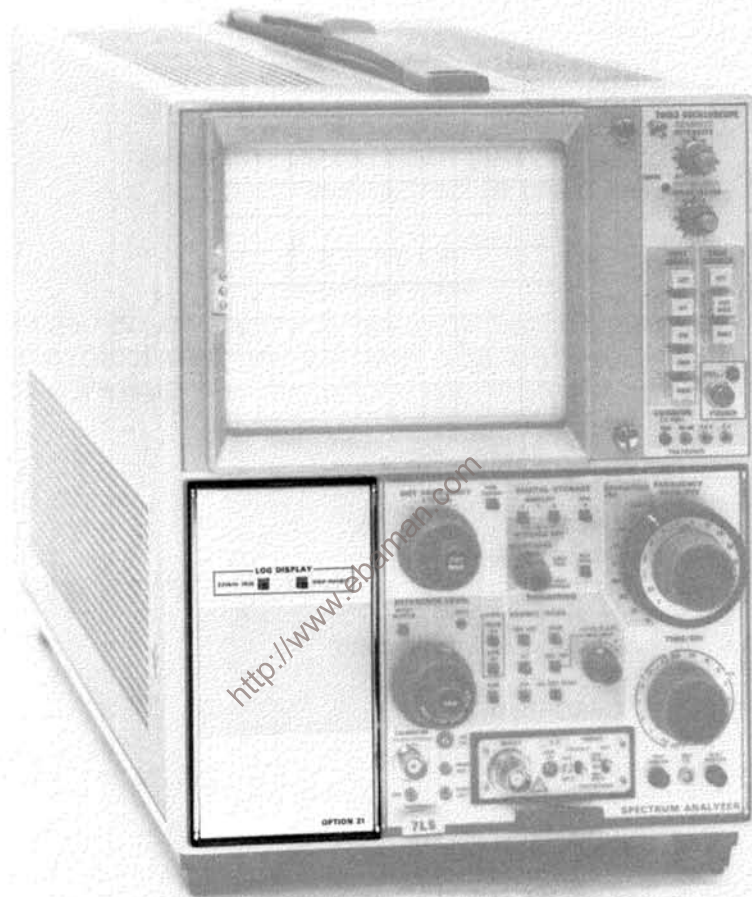

2155-19A

Fig. Option 21. 1-1. 7L5 Option 21 (Log Sweep).

SPECIFICATIONS

ELECTRICAL CHARACTERISTICS

The following characteristics and features apply to the Option 21 (Log Display) portion of the 7L5 Option 21 Spectrum Analyzer. 7L5 characteristics are not affected by this option. These characteristics are applicable over the environmental specifications criteria for the 7000-Series mainframe.

Frequency Range (Log Display): 250 Hz to 222.25 kHz, in increments of; 250 Hz—2.25 kHz, 2.25 kHz— 22.25 kHz, and 22.25 kHz—222.25 kHz.

Signal aberration (spread or overlap) generated at the crossover points (i.e. 2.25 kHz, 22.25 kHz, etc.) shall not exceed 0.5 minor division.

Display Flatness: +0.5 dB, -1.5 dB from 300 Hz to 180 kHz.

Acquisition Time/Full Log Display: Not more than 2.5 seconds. When 220 kHz IRIG (Log Display) is on, all except the REFERENCE LEVEL, Display Mode, and MAX HOLD selectors on the 7L5 are disabled. DOT FREQUENCY is not operational. When 220 kHz IRIG (Log Display) is off, the 7L5 operation is normal. When

SWP INHIBIT is enabled (illuminated) with Log Display, sweep operation is similar to single sweep mode. Data acquired during full log span period, is stored and displayed until the sweep is retriggered by switching SWP INHIBIT off.

ENVIRONMENTAL CHARACTERISTICS

As previously described, the instrument will meet the electrical characteristics over the environmental limits of the 7000-Series mainframe. Complete details on test procedure are described in the mainframe manual.

Operating and Storage Requirements

Operating Temperature Range: 0°C to +55°C.

Storage Temperature Range: -54°C to +75°C.

ACCESSORIES

Standard Accessories

Manual, Instruction

IRIG Log Graticule for 7L5 Option 21 331-0421-00

OPERATING AND PERFORMANCE CHECK INSTRUCTIONS

Introduction

This section describes the function of front panel selectors and provides an operational or performance check procedure. This operational check can be used to verify that the instrument is operating satisfactory and will serve as a guide for incoming inspection.

The Option 21 assembly provides a logarithmic display over the Inter Range Instrumentation Group (IRIG) requirements for the frequency range 250 Hz to 222.25 kHz. Log display is front panel selectable. Normal linear operation of the 7L5 is unchanged when the Option 21 is off. A IRIG graticule overlay, with subcarrier channels noted, is a standard accessory.

Function of the Panel Selectors

Two momentary pushbutton switches illuminate when their function is asserted.

220 kHz IRIG: Switches the spectrum analyzer span to a 300 Hz to 180 kHz log display. When on, all except the 7L5 Reference Level, Display Mode, (Log-Lin) and Max Hold selectors are disabled. Sweep consists of three segments with breakpoints at 2.25 kHz and 22.25 kHz. When off, the 7L5 operation is normal.

SWP INHIBIT: When activated (illuminated) the instrument will complete a full log display. The data acquired will remain stored and displayed until the switch is pushed again to change the state to off.

OPERATIONAL CHECK

This check will verify that the Option 21 assembly meets the electrical characteristics specified.

Equipment Required or Recommended

Test equipment specifications are the minimum required for these checks.

1. Two Sine Wave Signal Generators: Frequency range 250 Hz to 250 kHz. Variable output level. Output impedance 50 Ω or 600 Ω . TEKTRONIX SG 502 Oscillator of the TM 500 Series Test and Measurement instruments.

2. An "L"-Series plug-in module that matches the source impedance of the signal generator.

3. One, BNC "T" Adapter: Tektronix Part No. 103-0030-00.

1. Preliminary Preparation

a. Plug the 7L5 Option 21 into a 7000-Series mainframe with readout. Install an "L" series plug-in module into the 7L5. (Plug-in module input impedance should be the same as the signal generator output impedance.)

b. Turn the mainframe power on and allow a few minutes (about 5) warmup.

c. With the Log Display (220 kHz IRIG) off, calibrate the 7L5 span and position the display as described in the 7L5 Operating instructions.

2. Check Frequency Range and Display Flatness

a. Apply the output from two signal generators through a BNC "T" connector and coaxial cable to the input of the 7L5 plug-in module.

b. Set the frequency of one generator to 300 Hz and the frequency of the other generator to 180 kHz. Adjust the output level of both generators to 0 dBm.

c. Switch the 7L5 Display Mode to 10 dB/DIV and the 220 kHz IRIG Log Display on.

d. Check—the display for the 300 Hz and 180 kHz signals within +0.5, -1.5 dB, of 0 dBm. Note that only the Display Mode and Reference Level selectors of the 7L5 are functional when the Log Display is active.

3. Verify Sweep Inhibit Operation

a. Activate the sweep inhibit mode by pressing the SWP INHIBIT pushbutton.

b. Verify that the sweep is locked out, at the completion of one sweep by changing the Display Mode to 2 dB/DIV of LIN and observe that the display does not change.

WARNING

THE FOLLOWING SERVICING INSTRUCTIONS ARE FOR USE BY QUALIFIED PERSONNEL ONLY. TO AVOID PERSONAL INJURY, DO NOT PERFORM ANY SERVICING OTHER THAN THAT CONTAINED IN OPERATING INSTRUCTIONS UNLESS YOU ARE QUALIFIED TO DO SO.

CALIBRATION PROCEDURE

The following procedures describe the steps necessary to re-calibrate the Option 21 (Log Sweep) assembly. When calibrated, the instrument will operate within the characteristics specified in the Specifications section.

History Information

The instrument and manual are periodically evaluated and updated. If modifications require changes to the calibration procedure, history information applicable to earlier instruments is included.

Equipment Required

Equipment for calibration includes the equipment listed for the Performance Check plus the following additional equipment.

1. Oscilloscope: Vertical sensitivity 1 V/Div, sweep rate 1 s/Div. Tektronix 5000, 7000, or 400 series with appropriate time domain vertical and horizontal plug-in units.
2. Three plug-in extenders: Tektronix Part No. 067-0616-00.
3. Tuning screwdriver: 1/8 inch blade.

1. Preliminary Preparation

NOTE

The performance of the 7L5 must be checked and verified before calibrating the Option assembly. To gain access to the 7L5 for service and calibration, refer to the Maintenance Instructions.

Calibrate the instrument within its ambient operating temperature range. Allow a warmup period (with power on) of at least 10 minutes before making any calibration adjustments.

- a. Turn the mainframe power off. Remove the 7L5 Option 21 plug-in unit from the mainframe plug-in compartment.
- b. Remove the snap-on sidepanel to expose the circuit board and its adjustments.
- c. Connect the 7L5 Option 21 through flexible plug-in extenders (Calibration Fixture No. 067-0616-00) to the mainframe interface connectors, or, plug the 7L5 Option 21 back into the mainframe and remove the side panel of the mainframe.
- d. Switch the power on and after warmup, proceed with the calibration.

Calibration Procedure—7L5 Option 21

2. Calibrate the 7L5 Sweep Span to 10 kHz (2.25 kHz to 22.5 kHz)

a. Apply the output of two signal generators through a BNC "T" connector and coaxial cables to the Input of a "L" plug-in module. Termination impedance of the plug-in module should match the source impedance of the signal generators.

b. Set the 7L5 controls as follows:

DOT FREQUENCY	2.25 kHz
SPAN/DIV	0
RESOLUTION	30 Hz
Display Mode	10 dB/DIV
TIME/DIV	AUTO
Option 21 LOG DISPLAY	OFF

c. Set the frequency of one signal generator to the 7L5 dot frequency of 2.25 kHz (maximum response) then adjust the generator output for an on-screen amplitude reference level (i.e., 7 divisions).

d. Change the 7L5 DOT FREQUENCY to 22.25 kHz then adjust the frequency of the second signal generator to the 7L5 dot frequency. Again adjust the generator output level so the 22.25 kHz signal amplitude equals the 2.25 kHz signal.

e. Set the 7L5 controls as follows:

DOT FREQUENCY	2.25 kHz
SPAN/DIV	2 kHz
RESOLUTION	COUPLED
Digital Storage	Off

f. Calibrate the lower and upper limits of the 7L5 span to 2.25 kHz with R664 and 22.25 kHz with R665 respectively. Sweep should not overspan or underspan these limits (see Fig. 3-1).

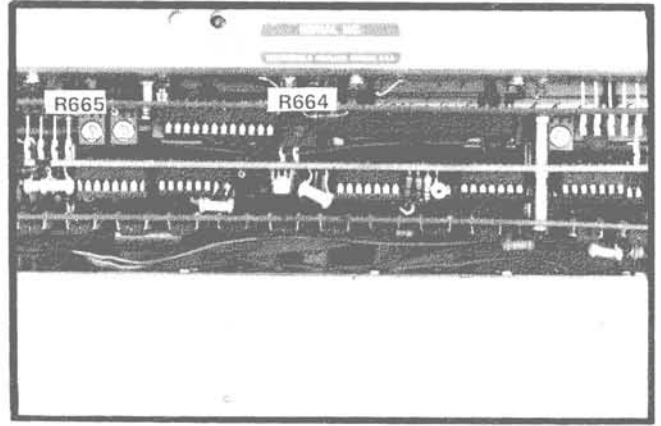

A. Sweep adjustment location on the 7L5.

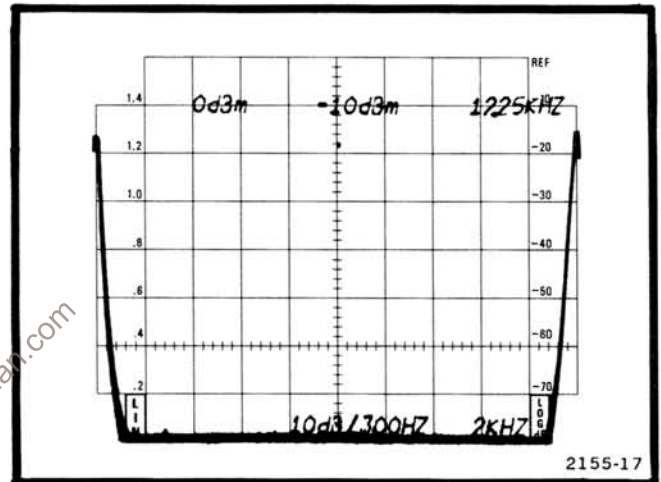

B. Typical calibrated 2.25 kHz span.

Fig. Option 21. 3-1. Adjustment location and typical calibrated display of the 7L5 2.25 kHz to 22.5 kHz span.

NOTE

Refer to the 7L5 Service manual for access instruction to these adjustments on the Sweep circuit board.

3. Calibrate the Log Sweep

a. Center the Resolution Gain (R5610) and Resolution Offset (R5625) adjustments (see Fig. 3-2).

b. With the signal generator frequencies of 2.25 kHz and 22.25 kHz applied to the 7L5 Input as described in step 2, adjust the Log Gain (R5595) and 22.25 kHz Offset (R5615) for minimum shift of the two signals as the analyzer sweeps through these two frequency points. See Fig. 3-3.

c. Change the signal generator frequencies to 500 Hz and 111.00 kHz.

d. Adjust the separation of the two signals to eight divisions with R5645 (Swp Gain), then, adjust R5605 (Swp Offset) so the two signals are aligned with their respective IRIG Log graticule markers (500 Hz and 111.00 kHz).

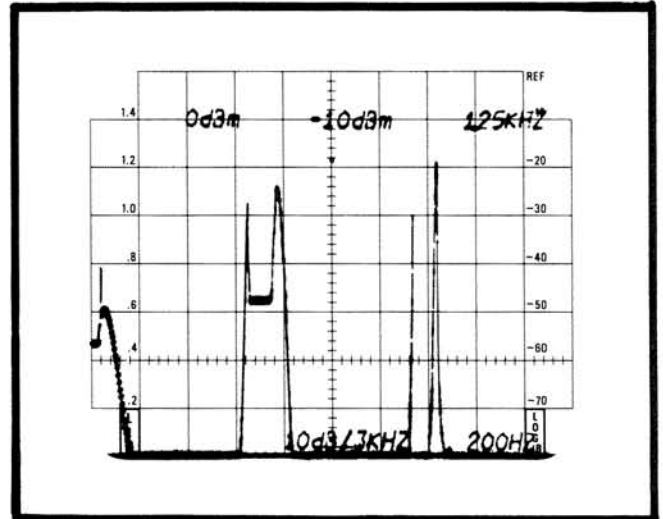

A. Typical display when log span and 22.5 kHz offset are incorrect.

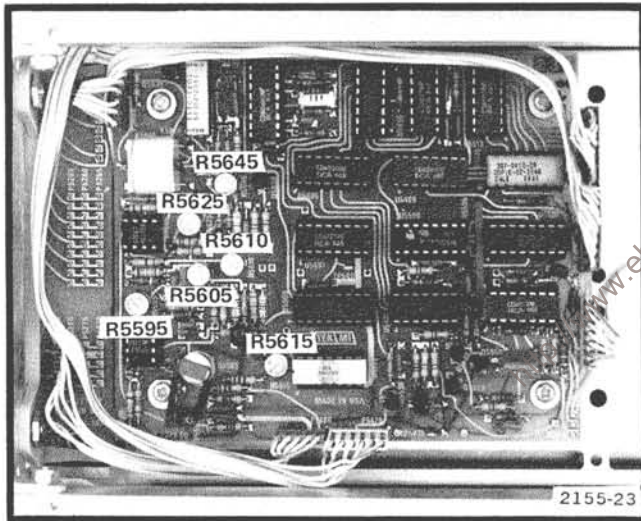
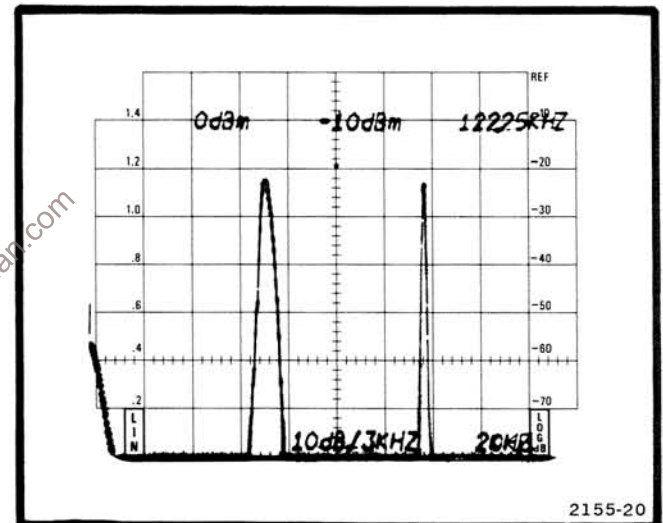

Fig. Option 21. 3-2. Calibration adjustment locations for Option 21.



B. Typical calibrated log display with 2.25 kHz and 22.5 kHz signal applied.

Fig. Option 21. 3-3. Log display calibration, 22.25 kHz.

Calibration Procedure—7L5 Option 21

4. Calibrate Resolution Bandwidth

a. Connect the probe from a test oscilloscope to pin 7 of U5605. Set the sweep rate to 500 ms/Div and vertical sensitivity to 1 V/Div.

b. Adjust the Resolution Gain (R5610) for 4 volt ramp and Resolution Offset (R5625) so the ramp sweeps from 0 to +4 volts (see Fig. 3-4).

c. Disconnect the test oscilloscope probe.

This completes the calibration of the Option 21 (Log Sweep) assembly.

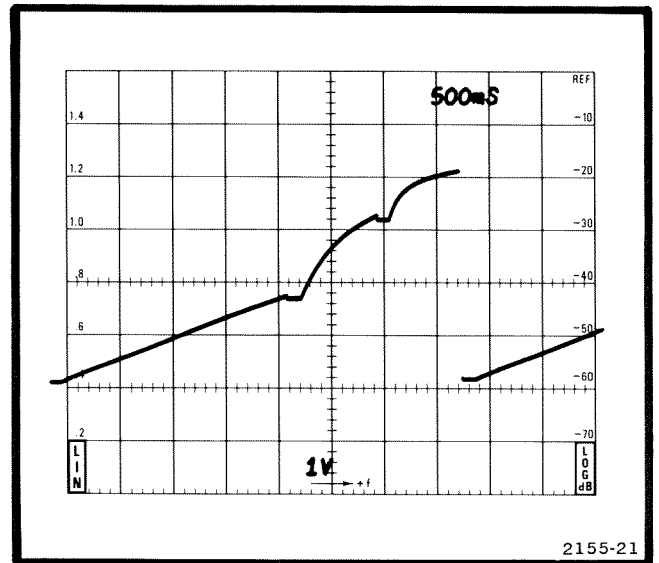

Fig. Option 21. 3-4. Composite sweep for log display.

CIRCUIT DESCRIPTION

General

The Log Sweep Option provides a log display from 250 Hz to 222.25 kHz, generated by combining three 7L5 sweeps. Each sweep spans a decade in frequency. The assembly circuits consist of a digital section to program the 7L5 center frequency, resolution, sweep time, and frequency span; plus an analog circuit to shape the sweep and automatically correct the resolution bandwidth and sweep time as the frequency increases.

During the 7L5 sweep holdoff period, the digital circuit generates and sends center frequency, frequency span, resolution, and sweep time data to the 7L5. This data then programs the 7L5 circuits for the next sweep. When the 7L5 sends Valid (sweep running), the digital circuit is inhibited and the analog circuit shapes and compresses the sweep horizontal (from the 7L5) into a logarithmic sweep. The sweep is then sent to the 7L5 digital storage circuit. After three sweeps the sweep horizontal out of the digital storage, is a composite of the three sweeps and the display is a log span from 250 Hz to 222.25 kHz. Fig 4-1 illustrates the conversion sequence. This display meets the requirements of the Inter Range Instrumentation Group (IRIG) within the specified frequency range.

Detailed Description

Valid input from the 7L5 is high during sweep time. It is inverted by U5455E, differentiated by C5493-R5493, then diode CR5493 couples the positive pulse portion of the differentiated signal to the Set input of two flip-flop IC's U5466A and U5466B. When U5466B is set, a master oscillator, consisting of U5455C, U5455B is enabled and outputs a clock with a frequency of approximately 1.1 kHz.

The positive-going portion of $\overline{\text{Valid}}$, clocks a modulo-3 counter (U5497A & B). This counter is initially reset to 00 (by the Q output of U5542A) when the Option 21 is switched on; so the counter is clocked through 0,1,2, for each series of three $\overline{\text{Valid}}$ input signals.

When the master oscillator is enabled, the 1st clock pulse is gated through U5476B and inverted by U5481B to load the shift register U5505 with a byte of data out of ROM U5500. The initial address into ROM U5500 is 0000, derived from the output of the 6-bit counter (U5485A & B) and the output of the modulo-3 counter (U5497A & B). The data in the shift register (U5505) is now clocked out on line N as center frequency data and into shift registers U5513, U5489.

With the 8th clock pulse the A output of U5485B goes to 1 to change the address to ROM U5500 and another byte of data is loaded into U5505 (8th pulse is gated through U5476B). The 16th clock changes the B output of U5485B to 1. This generates a new byte of data out of ROM U5500 and again this is loaded into the shift register U5505. The high on the B output of U5485B enables gate U5476C so that the next count to the K input of U5466A goes high. The 17th pulse now clocks the flip-flop, inhibits the gate U5476D, and terminates the clock to the MOS IC (on line N) for the 7L5. The 24th pulse changes the output of the 6 bit counter (U5485B) and loads a new byte of data into the shift register U5505. The 32nd pulse changes the output of U5485B to 100 (4) with the high out of C, strobing data in shift registers U5513 and U5489 to output latches within the IC. Up to this time, excess data bits were clocked out of U5489. The 14 bits of data strobed from the two registers in U5513, U5489 provide a new and different program for the 7L5 frequency span, resolution, and sweep time.

The high on this line (C output of U5485B) allows the next clock pulse to clock the flip-flop U5466B and disable the oscillator. The Option 21 circuit is now ready for the 7L5 sweep to run.

At the end of the next $\overline{\text{Valid}}$ the modulo-3 counter shifts up one count, the oscillator is enabled, and the process repeats with a 1 at the A₂ input to ROM U5500, U5497A & B counts 0,1,2, then repeats. The output of this counter is also applied through R5412 and R5614 to the input of operational amplifier U5605A so; as the counter cycles, the input dc level to amplifier U5605A is offset and the sweep voltages to the amplifier input are stacked for three sweeps.

Calibration Procedure—7L5 Option 21

The analog section log shaping circuit consists of two transistors, within a common package (U5585), and amplifier U5580A. The base-emitter junction of one transistor is in the feedback loop of amplifier U5580A. So the junction characteristics provide the logarithmic gain characteristics for the amplifier. The other transistor provides temperature compensation to maintain the response characteristics as temperature varies. The input of the amplifier is offset so all sweeps out of the logarithmic circuit start from a common reference level.

The compressed log sweeps out of buffer amplifier U5580B are applied to a gain and offset amplifier U5605A. As previously described, the dc level at the input of U5605A is changed by the digital circuitry to offset each sweep. The output of U5605A is therefore three log sweeps with each sweep stacked on the other. Gain and Offset adjustments, R5595 and R5605, are set so the three decades of frequency span do not overlap and the total sweep amplitude covers 250 Hz to 222.25 kHz. The output of U5605A is then fed through Swp Gain adjustment R5645 to the Horizontal of the 7L5 digital storage.

The three sweeps out of U5605A are also fed to another operational amplifier with a Gain and Offset adjustment

(R5610 and R5625) to drive the 7L5 resolution filter and sweep timing circuits. These are adjusted to provide optimum resolution bandwidth and sweep rate as frequency increases.

A sweep inhibit circuit, consisting of gates and latches, allows the 7L5 to make three sweeps for one complete log display and then inhibit the sweep until the front panel SWEEP INHIBIT button is pushed again. When SWP INHIBIT is activated, U5542B is clocked and \overline{Q} goes low. When all inputs to gates U5562C and U5572D are low (after the 3rd sweep) the output of U5572A, and U5572B, latches low. Q5520 is switched on to generate Sweep Inhibit so, the 7L5 sweep is locked out until the latch is again flipped by pushing the SWP INHIBIT button or, when U5542B is reset at the initial turn on.

Flip-flop U5542A activates the Option 21 circuit so the display becomes a log display. When \overline{Q} of U5542A switches low, the output of tri-state buffers (U5509) are enabled, the cursor circuit of the 7L5 is disabled so the signals are peak detected, and the modulo-3 counter (U5497) is enabled, sweep inhibit flop-flop U5542B is reset, shift registers U5513, U5489 are enabled, and U5466A and U5466B are set.

<http://www.ebaman.com>

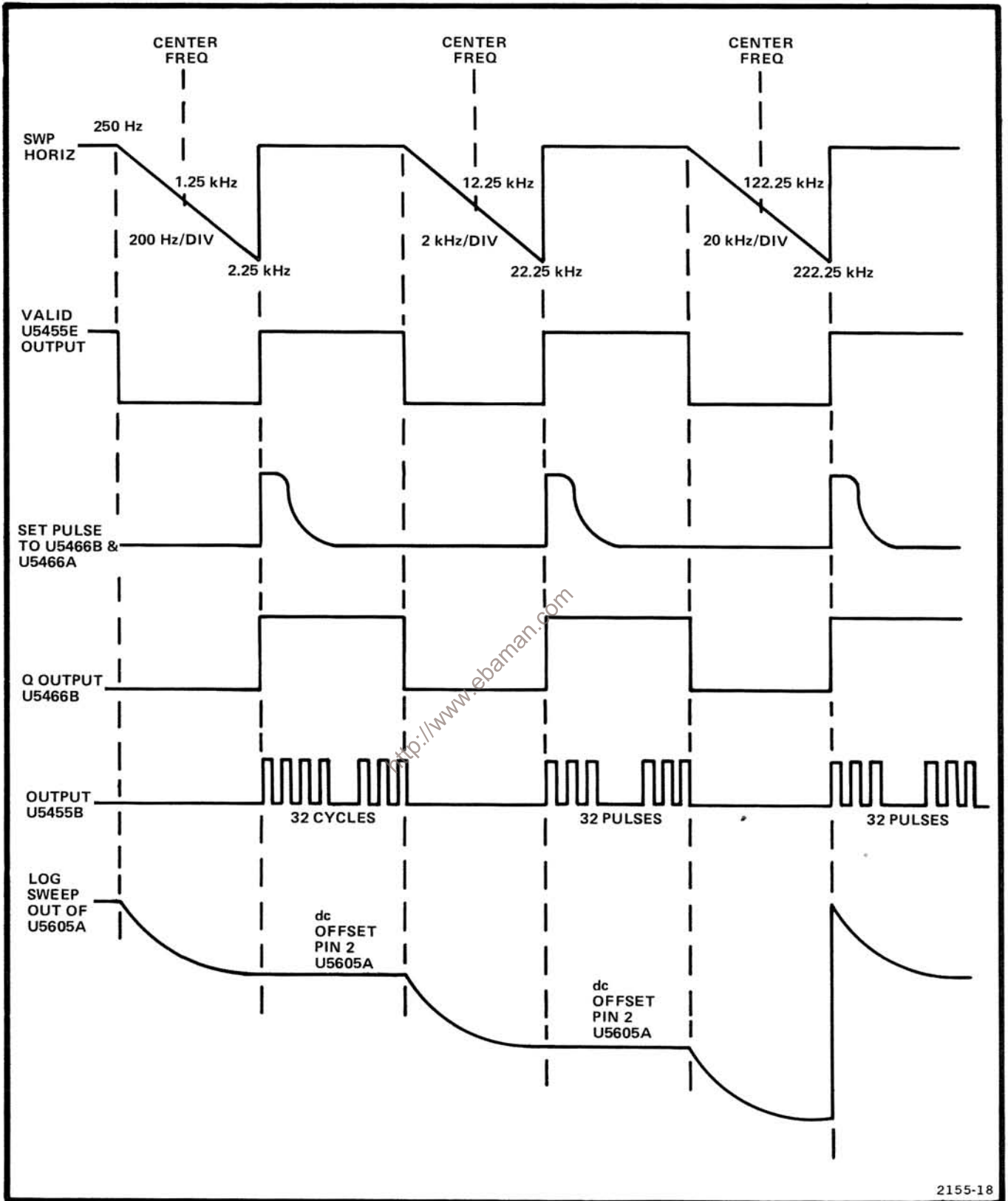

2155-18

Fig. Option 21. 4-1. Sequence of signals to convert three 7L5 sweeps to one composite log sweep.

MAINTENANCE INSTRUCTIONS

Introduction

Preventative maintenance, troubleshooting techniques, and corrective maintenance procedures for the 7L5 are applicable for the Option 21 assembly. The following is additional information pertinent to the Option 21 Assembly.

Preparing the Instrument for Service

1. Turn the mainframe power off. Remove the 7L5 Option 21 from the plug-in compartment.
2. Remove the snap-on side panel to expose the circuit board.
3. Connect the 7L5 Option 21 through flexible plug-in extenders (Calibration Fixture No. 067-0616-00) to the

mainframe interface connectors; or, plug the 7L5 Option 21 back in the mainframe and remove the left side panel of the mainframe.

4. Switch the power on and proceed with calibration or troubleshooting.

Replacing the Heater on Transistor Q5585

The heater element R5577 is attached to the top of the transistor with epoxy glue. When the heater is glued to the case, ensure that the leads of the heater do not touch the transistor case.

Replacing the Assembly

Refer to the replacement procedure described in the Maintenance section for the Option 25 assembly.

<http://www.ebaman.com>

REPLACEABLE ELECTRICAL PARTS

PARTS ORDERING INFORMATION

Replacement parts are available from or through your local Tektronix, Inc. Field Office or representative.

Changes to Tektronix instruments are sometimes made to accommodate improved components as they become available, and to give you the benefit of the latest circuit improvements developed in our engineering department. It is therefore important, when ordering parts, to include the following information in your order: Part number, instrument type or number, serial number, and modification number if applicable.

If a part you have ordered has been replaced with a new or improved part, your local Tektronix, Inc. Field Office or representative will contact you concerning any change in part number.

Change information, if any, is located at the rear of this manual.

SPECIAL NOTES AND SYMBOLS

X000 Part first added at this serial number
00X Part removed after this serial number

ITEM NAME

In the Parts List, an Item Name is separated from the description by a colon (:). Because of space limitations, an Item Name may sometimes appear as incomplete. For further Item Name identification, the U.S. Federal Cataloging Handbook H6-1 can be utilized where possible.

ABBREVIATIONS

ACTR	ACTUATOR	PLSTC	PLASTIC
ASSY	ASSEMBLY	QTZ	QUARTZ
CAP	CAPACITOR	RECP	RECEPTACLE
CER	CERAMIC	RES	RESISTOR
CKT	CIRCUIT	RF	RADIO FREQUENCY
COMP	COMPOSITION	SEL	SELECTED
CONN	CONNECTOR	SEMICOND	SEMICONDUCTOR
ELCTLT	ELECTROLYTIC	SENS	SENSITIVE
ELEC	ELECTRICAL	VAR	VARIABLE
INCAND	INCANDESCENT	WW	WIREWOUND
LED	LIGHT EMITTING DIODE	XFMR	TRANSFORMER
NONWIR	NON WIREWOUND	XTAL	CRYSTAL

CROSS INDEX—MFR. CODE NUMBER TO MANUFACTURER

Mfr. Code	Manufacturer	Address	City, State, Zip
01121	ALLEN-BRADLEY COMPANY	1201 2ND STREET SOUTH	MILWAUKEE, WI 53204
03888	KDI PYROFILM CORPORATION	60 S JEFFERSON ROAD	WHIPPANY, NJ 07981
04713	MOTOROLA, INC., SEMICONDUCTOR PROD. DIV.	5005 E MCDOWELL RD, PO BOX 20923	PHOENIX, AZ 85036
31951	TRIRIDGE CORPORATION	PO BOX 12420, GREATER PITTSBURGH AIRPORT	PITTSBURGH, PA 15231
32997	BOURNS, INC., TRIMPOT PRODUCTS DIV.	1200 COLUMBIA AVE.	RIVERSIDE, CA 92507
50157	MIDWEST COMPONENTS INC.	P. O. BOX 787 1981 PORT CITY BLVD.	MUSKEGON, MI 49443
50579	LITRONIX INC.	19000 HOMESTEAD RD.	CUPERTINO, CA 95014
56289	SPRAGUE ELECTRIC CO.		NORTH ADAMS, MA 01247
72982	ERIE TECHNOLOGICAL PRODUCTS, INC.	644 W. 12TH ST.	ERIE, PA 16512
80009	TEKTRONIX, INC.	P O BOX 500	BEAVERTON, OR 97077
90201	MALLORY CAPACITOR CO., DIV. OF P. R. MALLORY AND CO., INC.	3029 E. WASHINGTON STREET P. O. BOX 372	INDIANAPOLIS, IN 46206
91637	DALE ELECTRONICS, INC.	P. O. BOX 609	COLUMBUS, NE 68601

<http://www.ebaman.com>

Ckt No.	Tektronix Part No.	Serial/Model No. Eff	Dscont	Name & Description	Mfr Code	Mfr Part Number
A5000	670-4832-00			CKT BOARD ASSY:FRONT PANEL	80009	670-4832-00
A5250	670-4676-00			CKT BOARD ASSY:OPTION MAIN FRAME CONNECTOR	80009	670-4676-00
A5290	670-4675-00			CKT BOARD ASSY:OPTION INTERFACE	80009	670-4675-00
A5400	670-4750-00			CKT BOARD ASSY:LOG SWEEP	80009	670-4750-00
C5457	281-0536-00			CAP., FXD, CER DI:1000PF, 10%, 500V	72982	301000 X5P0 102K
C5459	283-0204-00			CAP., FXD, CER DI:0.01UF, 20%, 50V	72982	8121N061Z5U0103M
C5461	283-0204-00			CAP., FXD, CER DI:0.01UF, 20%, 50V	72982	8121N061Z5U0103M
C5470	283-0177-00			CAP., FXD, CER DI:1UF, +80-20%, 25V	72982	8131N039 E 105Z
C5472	283-0010-00			CAP., FXD, CER DI:0.05UF, +100-20%, 50V	56289	273C20
C5473	283-0010-00			CAP., FXD, CER DI:0.05UF, +100-20%, 50V	56289	273C20
C5474	283-0010-00			CAP., FXD, CER DI:0.05UF, +100-20%, 50V	56289	273C20
C5475	283-0010-00			CAP., FXD, CER DI:0.05UF, +100-20%, 50V	56289	273C20
C5481	283-0024-00			CAP., FXD, CER DI:0.1UF, +80-20%, 30V	72982	8121N083Z5U0104Z
C5489	283-0024-00			CAP., FXD, CER DI:0.1UF, +80-20%, 30V	72982	8121N083Z5U0104Z
C5493	283-0024-00			CAP., FXD, CER DI:0.1UF, +80-20%, 30V	72982	8121N083Z5U0104Z
C5533	283-0212-00			CAP., FXD, CER DI:2UF, 20%, 50V	72982	8141N064Z5U205M
C5550	283-0058-00			CAP., FXD, CER DI:0.027UF, 10%, 100V	72982	8131N147X7R0273K
C5572	283-0024-00			CAP., FXD, CER DI:0.1UF, +80-20%, 30V	72982	8121N083Z5U0104Z
C5576	283-0024-00			CAP., FXD, CER DI:0.1UF, +80-20%, 30V	72982	8121N083Z5U0104Z
C5580	283-0010-00			CAP., FXD, CER DI:0.05UF, +100-20%, 50V	56289	273C20
C5590	290-0536-00			CAP., FXD, ELCTLT:10UF, 20%, 25V	90201	TDC106M025FL
C5592	283-0204-00			CAP., FXD, CER DI:0.01UF, 20%, 50V	72982	8121N061Z5U0103M
C5605	283-0204-00			CAP., FXD, CER DI:0.01UF, 20%, 50V	72982	8121N061Z5U0103M
C5585	283-0204-00			CAP., FXD, CER DI:0.01UF, 20%, 50V	72982	8121N061Z5U0103M
CR5466	152-0141-02			SEMICONV DEVICE:SILICON, 30V, 150MA	80009	152-0141-02
CR5481	152-0141-02			SEMICONV DEVICE:SILICON, 30V, 150MA	80009	152-0141-02
CR5489	152-0141-02			SEMICONV DEVICE:SILICON, 30V, 150MA	80009	152-0141-02
CR5493	152-0141-02			SEMICONV DEVICE:SILICON, 30V, 150MA	80009	152-0141-02
CR5533	152-0141-02			SEMICONV DEVICE:SILICON, 30V, 150MA	80009	152-0141-02
CR5550	150-1050-00			LT EMITTING DIO:RED	50579	RL-T1
CR5560	150-1050-00			LT EMITTING DIO:RED	50579	RL-T1
CR5620	152-0141-02			SEMICONV DEVICE:SILICON, 30V, 150MA	80009	152-0141-02
CR5630	152-0141-02			SEMICONV DEVICE:SILICON, 30V, 150MA	80009	152-0141-02
CR5640	152-0141-02			SEMICONV DEVICE:SILICON, 30V, 150MA	80009	152-0141-02
CR5642	152-0141-02			SEMICONV DEVICE:SILICON, 30V, 150MA	80009	152-0141-02
CR5647	152-0141-02			SEMICONV DEVICE:SILICON, 30V, 150MA	80009	152-0141-02
CR5649	152-0141-02			SEMICONV DEVICE:SILICON, 30V, 150MA	80009	152-0141-02
CR5651	152-0141-02			SEMICONV DEVICE:SILICON, 30V, 150MA	80009	152-0141-02
HP5577	307-0561-00			RES., THERMAL:800 OHM	50157	PTC 101-2
K5620	148-0102-00			REED, RELAY:DPST, 100V, 0.2A	31951	250-200-05
L5470	108-0598-00			COIL, RF:200UH	80009	108-0598-00
L5645	108-0358-00			COIL, REED SW:12VDC, SINGLE REED	80009	108-0358-00
Q5520	151-0188-00			TRANSISTOR:SILICON, PNP	80009	151-0188-00
Q5525	151-0190-00			TRANSISTOR:SILICON, NPN	80009	151-0190-00
Q5530	151-0190-00			TRANSISTOR:SILICON, NPN	80009	151-0190-00
Q5550	151-0190-00			TRANSISTOR:SILICON, NPN	80009	151-0190-00
Q5560	151-0190-00			TRANSISTOR:SILICON, NPN	80009	151-0190-00
Q5585	151-0261-00			TRANSISTOR:SILICON, PNP, DUAL	80009	151-0261-00
Q5630	151-0190-00			TRANSISTOR:SILICON, NPN	80009	151-0190-00
Q5635	151-0188-00			TRANSISTOR:SILICON, PNP	80009	151-0188-00
R5339	315-0103-00			RES., FXD, CMPSN:10K OHM, 5%, 0.25W	01121	CB1035
R5455	315-0754-00			RES., FXD, CMPSN:750K OHM, 5%, 0.25W	01121	CB7545

Replaceable Electrical Parts—7L5 Option 21

Ckt No.	Tektronix Part No.	Serial/Model No. Eff	Dscont	Name & Description	Mfr Code	Mfr Part Number
R5457	315-0394-00			RES., FXD, CMPSN: 390K OHM, 5%, 0.25W	01121	CB3945
R5459	315-0472-00			RES., FXD, CMPSN: 4.7K OHM, 5%, 0.25W	01121	CB4725
R5461	315-0472-00			RES., FXD, CMPSN: 4.7K OHM, 5%, 0.25W	01121	CB4725
R5466	315-0103-00			RES., FXD, CMPSN: 10K OHM, 5%, 0.25W	01121	CB1035
R5481	315-0103-00			RES., FXD, CMPSN: 10K OHM, 5%, 0.25W	01121	CB1035
R5482	315-0104-00			RES., FXD, CMPSN: 100K OHM, 5%, 0.25W	01121	CB1045
R5489	315-0103-00			RES., FXD, CMPSN: 10K OHM, 5%, 0.25W	01121	CB1035
R5493	315-0103-00			RES., FXD, CMPSN: 10K OHM, 5%, 0.25W	01121	CB1035
R5505	307-0446-00			RES, NTWK, FXD FI: 10K OHM, 20%, (9) RES	03888	A3HT08
R5515	307-0504-00			RES NTWK, FXD, FI: (15) 300K OHM, 2%	01121	316A304
R5516	315-0103-00			RES., FXD, CMPSN: 10K OHM, 5%, 0.25W	01121	CB1035
R5520	315-0103-00			RES., FXD, CMPSN: 10K OHM, 5%, 0.25W	01121	CB1035
R5523	315-0102-00			RES., FXD, CMPSN: 1K OHM, 5%, 0.25W	01121	CB1025
R5525	315-0103-00			RES., FXD, CMPSN: 10K OHM, 5%, 0.25W	01121	CB1035
R5527	315-0103-00			RES., FXD, CMPSN: 10K OHM, 5%, 0.25W	01121	CB1035
R5530	315-0243-00			RES., FXD, CMPSN: 10K OHM, 5%, 0.25W	01121	CB2435
R5535	315-0474-00			RES., FXD, CMPSN: 470K OHM, 5%, 0.25W	01121	CB4745
R5537	315-0103-00			RES., FXD, CMPSN: 10K OHM, 5%, 0.25W	01121	CB1035
R5542	315-0111-00			RES., FXD, CMPSN: 110 OHM, 5%, 0.25W	01121	CB1115
R5546	315-0222-00			RES., FXD, CMPSN: 2.2K OHM, 5%, 0.25W	01121	CB2225
R5550	315-0201-00			RES., FXD, CMPSN: 200 OHM, 5%, 0.25W	01121	CB2015
R5553	315-0303-00			RES., FXD, CMPSN: 30K OHM, 5%, 0.25W	01121	CB3035
R5555	315-0101-00			RES., FXD, CMPSN: 100 OHM, 5%, 0.25W	01121	CB1015
R5557	315-0111-00			RES., FXD, CMPSN: 110 OHM, 5%, 0.25W	01121	CB1115
R5560	315-0201-00			RES., FXD, CMPSN: 200 OHM, 5%, 0.25W	01121	CB2015
R5565	315-0222-00			RES., FXD, CMPSN: 2.2K OHM, 5%, 0.25W	01121	CB2225
R5568	315-0303-00			RES., FXD, CMPSN: 30K OHM, 5%, 0.25W	01121	CB3035
R5574	315-0510-00			RES., FXD, CMPSN: 51 OHM, 5%, 0.25W	01121	CB5105
R5575	315-0510-00			RES., FXD, CMPSN: 51 OHM, 5%, 0.25W	01121	CB5105
R5579	315-0753-00			RES., FXD, CMPSN: 75K OHM, 5%, 0.25W	01121	CB7535
R5580	315-0471-00			RES., FXD, CMPSN: 470 OHM, 5%, 0.25W	01121	CB4715
R5581	321-0256-00			RES., FXD, FILM: 4.53K OHM, 1%, 0.125W	91637	MFF1816G45300F
R5582	321-0093-00			RES., FXD, FILM: 90.9 OHM, 1%, 0.125W	91637	MFF1816G90R90F
R5583	321-0289-00			RES., FXD, FILM: 10K OHM, 1%, 0.125W	91637	MFF1816G10001F
R5584	315-0242-00			RES., FXD, CMPSN: 2.4K OHM, 5%, 0.25W	01121	CB2425
R5585	321-0288-00			RES., FXD, FILM: 9.76K OHM, 1%, 0.125W	91637	MFF1816G97600F
R5588	321-0274-00			RES., FXD, FILM: 6.98K OHM, 1%, 0.125W	91637	MFF1816G69800F
R5590	315-0302-00			RES., FXD, CMPSN: 3K OHM, 5%, 0.25W	01121	CB3025
R5592	321-0288-00			RES., FXD, FILM: 9.76K OHM, 1%, 0.125W	91637	MFF1816G97600F
R5595	311-1269-00			RES., VAR, NONWIR: 20K OHM, 10%, 0.50W	32997	3329P-L58-203
R5597	315-0393-00			RES., FXD, CMPSN: 39K OHM, 5%, 0.25W	01121	CB3935
R5599	321-0408-00			RES., FXD, FILM: 174K OHM, 1%, 0.125W	91637	MFF1816G17402F
R5602	321-0274-00			RES., FXD, FILM: 6.98K OHM, 1%, 0.125W	91637	MFF1816G69800F
R5605	311-1271-00			RES., VAR, NONWIR: 50K OHM, 10%, 0.50W	32997	3329P-L58-503
R5608	321-0358-00			RES., FXD, FILM: 52.3K OHM, 1%, 0.125W	91637	MFF1816G52301F
R5610	311-1272-00			RES., VAR, NONWIR: 100K OHM, 10%, 0.50W	32997	3329P-L58-104
R5612	321-0373-00			RES., FXD, FILM: 75K OHM, 1%, 0.125W	91637	MFF1816G75001F
R5614	321-0341-00			RES., FXD, FILM: 34.8K OHM, 1%, 0.125W	91637	MFF1816G34801F
R5615	311-1267-00			RES., VAR, NONWIR: 5K OHM, 10%, 0.50W	32997	3329P-L58-502
R5616	315-0513-00			RES., FXD, CMPSN: 51K OHM, 5%, 0.25W	01121	CB5135
R5620	321-0356-00			RES., FXD, FILM: 49.9K OHM, 1%, 0.125W	91637	MFF1816G49901F
R5623	315-0104-00			RES., FXD, CMPSN: 100K OHM, 5%, 0.25W	01121	CB1045
R5625	311-1274-00			RES., VAR, NONWIR: 500K OHM, 10%, 0.50W	32997	3329P-L58-504
R5630	315-0103-00			RES., FXD, CMPSN: 10K OHM, 5%, 0.25W	01121	CB1035
R5635	315-0103-00			RES., FXD, CMPSN: 10K OHM, 5%, 0.25W	01121	CB1035
R5639	315-0103-00			RES., FXD, CMPSN: 10K OHM, 5%, 0.25W	01121	CB1035

Ckt No.	Tektronix Part No.	Serial/Model No. Eff	Dscont	Name & Description	Mfr Code	Mfr Part Number
R5645	311-1263-00			RES.,VAR, NONWIR:1K OHM,10%,0.50W	32997	3329P-L58-102
R5647	321-0370-00			RES.,FXD,FILM:69.8K OHM,1%,0.125W	91637	MFF1816G69801F
R5649	321-0403-00			RES.,FXD,FILM:154K OHM,1%,0.125W	91637	MFF1816G15402F
R5672	315-0100-00			RES.,FXD,CMPSN:10 OHM,5%,0.25W	01121	CB1005
R5676	315-0100-00			RES.,FXD,CMPSN:10 OHM,5%,0.25W	01121	CB1005
S5550	263-0019-00			SWITCH PB ASSY:MOMENTARY	80009	263-0019-00
S5560	263-0019-00			SWITCH PB ASSY:MOMENTARY	80009	263-0019-00
S5643	260-0817-00			SWITCH, REED: SPDT, 0.25A, 100V	80009	260-0817-00
U5455	156-0494-00			MICROCIRCUIT,DI:HEX INVERTER/BUFFER	80009	156-0494-00
U5466	156-0525-00			MICROCIRCUIT,DI:DUAL J-K MASTER SLAVE F-F	80009	156-0525-00
U5476	156-0577-00			MICROCIRCUIT,DI:QUAD 2 INPUT AND GATE	80009	156-0577-00
U5481	156-0575-00			MICROCIRCUIT,DI:3 INPUT NOR GATE	80009	156-0575-00
U5485	156-0579-00			MICROCIRCUIT,DI:DUAL 4-BIT BIN COUNTER	80009	156-0579-00
U5489	156-0796-00			MICROCIRCUIT,DI:8 STG SHF & STORE BUS RGTR	80009	156-0796-00
U5497	156-0525-00			MICROCIRCUIT,DI:DUAL J-K MASTER SLAVE F-F	80009	156-0525-00
U5500	156-0785-13			MICROCIRCUIT,DI:PROM	80009	U5500
U5505	156-0625-00			MICROCIRCUIT,DI:8 BIT PRL LOAD SHIFT RGTR	80009	156-0625-00
U5509	156-0649-00			MICROCIRCUIT,DI:3 STATE HEX. NON INVT BFR	80009	156-0649-00
U5513	156-0796-00			MICROCIRCUIT,DI:8 STG SHF & STORE BUS RGTR	80009	156-0796-00
U5542	156-0366-00			MICROCIRCUIT,DI:DUAL D-TYPE F-F	80009	156-0366-00
U5572	156-0349-00			MICROCIRCUIT,DI:QUAD 2-INPUT NOR GATE	80009	156-0349-00
U5580	156-0158-00			MICROCIRCUIT,LI:DUAL OPERATIONAL AMPLIFIER	80009	156-0158-00
U5605	156-0158-00			MICROCIRCUIT,LI:DUAL OPERATIONAL AMPLIFIER	80009	156-0158-00
VR5595	152-0514-00			SEMICONV DEVICE:ZENER,0.4W,10V,1%	80009	152-0514-00
VR5620	152-0195-00			SEMICONV DEVICE:ZENER,0.4W,5.1V,5%	80009	152-0195-00
VR5635	152-0168-00			SEMICONV DEVICE:ZENER,0.4W,12V,5%	04713	1N963B

<http://www.ebama.com>

DIAGRAMS AND CIRCUIT BOARD ILLUSTRATIONS

Symbols and Reference Designators

Graphic symbols for electrical and logic symbols, used on the diagrams, are based on ANSI Y32.2, 1975, and ANSI Y32.14, 1973, "American National Standards Institute." Logic symbols depict the logic function of the device in positive logic. Copies of these standards can be obtained from the Institute of Electrical and Electronics Engineers, 345 East 47th Street, New York, N.Y., 11017. Exceptions and additions are shown on this sample diagram. These conform or are based on the manufacturers data sheet and industry trends.

Resistor values are in ohms, unless noted otherwise, and the Ω symbol is omitted. Capacitor values ≥ 1 (e.g. 10) are in picofarads (pF) and values < 1 (e.g. 0.01) are in microfarads unless otherwise noted.

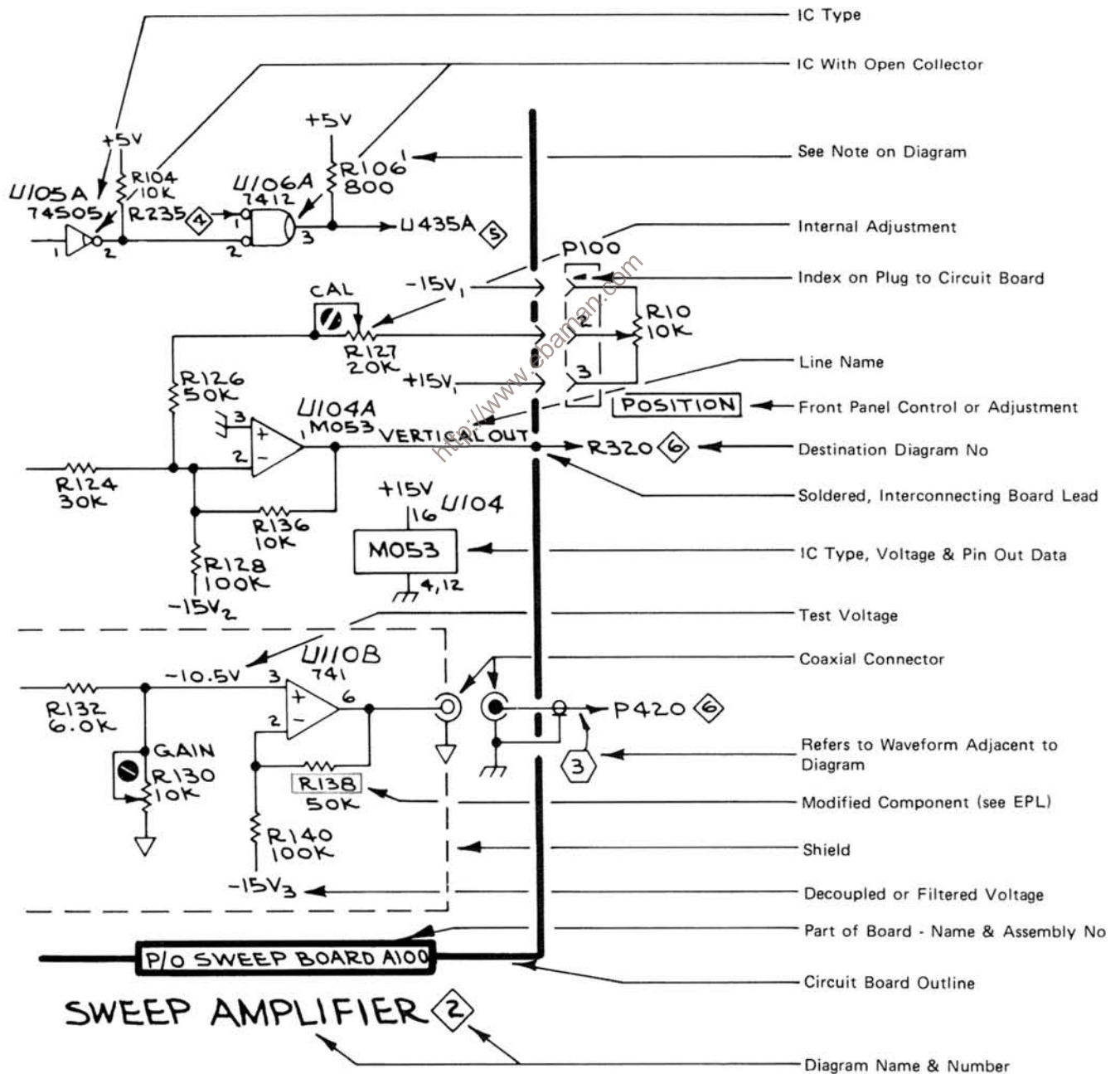

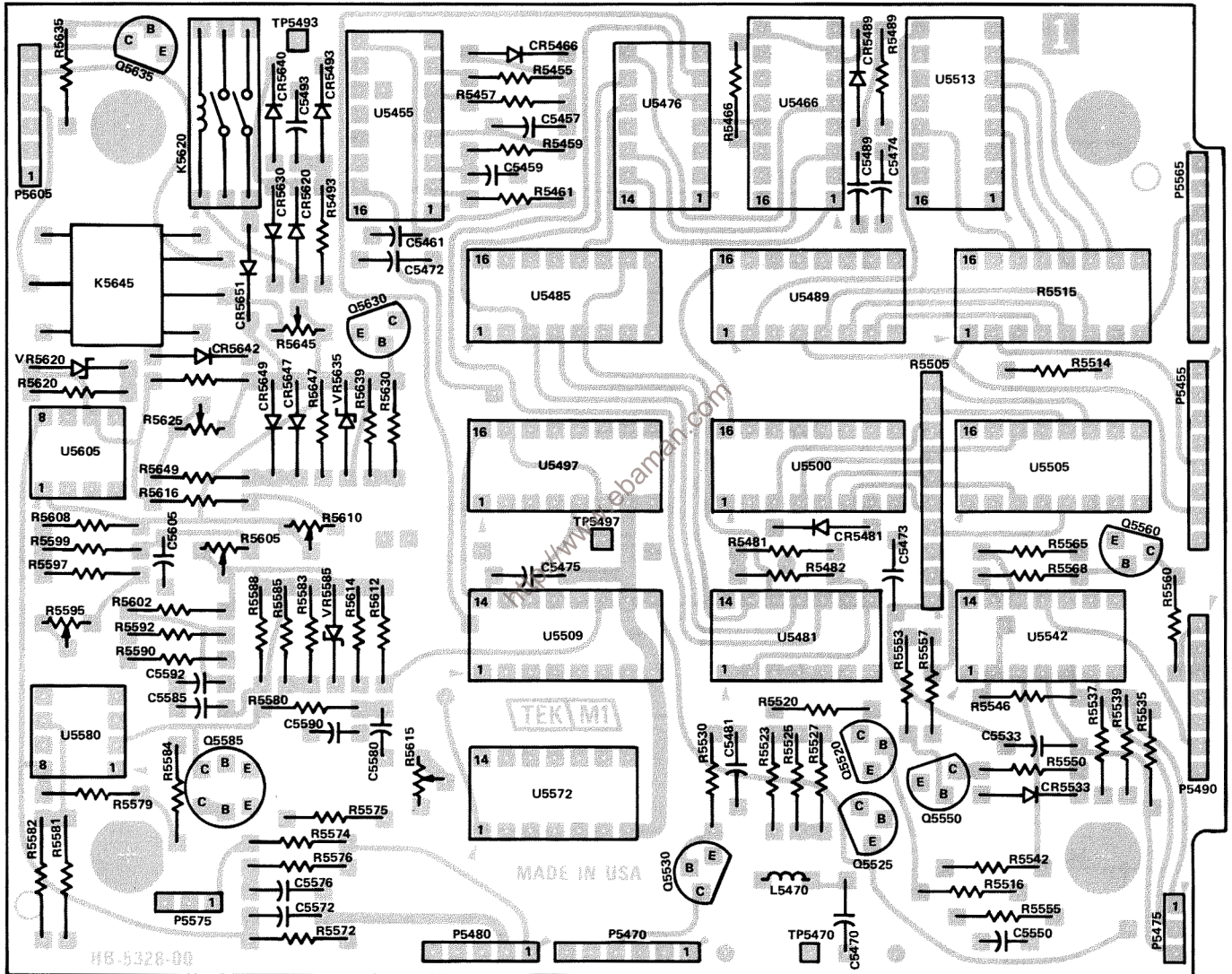

7B-5328-00

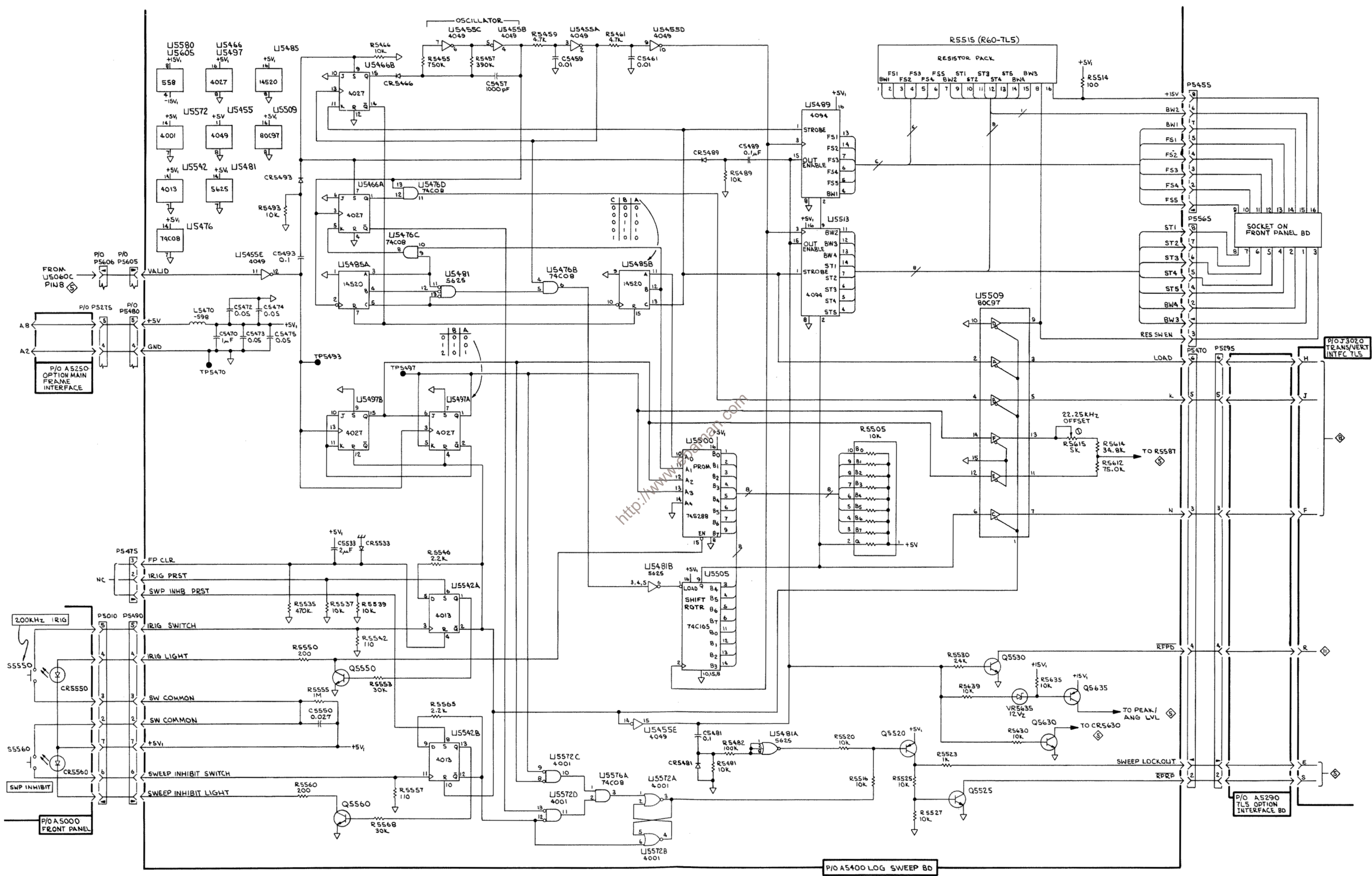

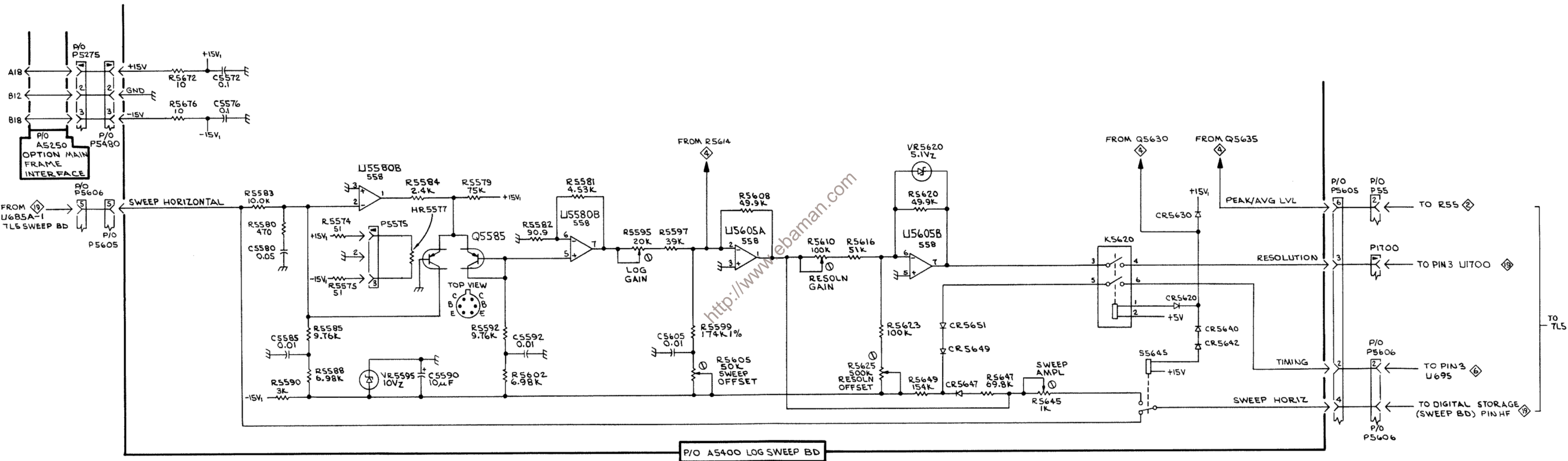

TL5 OPTION 21

2155-22

LOG DISPLAY SHAPING CKT 2 vs

REPLACEABLE MECHANICAL PARTS

PARTS ORDERING INFORMATION

Replacement parts are available from or through your local Tektronix, Inc. Field Office or representative.

Changes to Tektronix instruments are sometimes made to accommodate improved components as they become available, and to give you the benefit of the latest circuit improvements developed in our engineering department. It is therefore important, when ordering parts, to include the following information in your order: Part number, instrument type or number, serial number, and modification number if applicable.

If a part you have ordered has been replaced with a new or improved part, your local Tektronix, Inc. Field Office or representative will contact you concerning any change in part number.

Change information, if any, is located at the rear of this manual.

SPECIAL NOTES AND SYMBOLS

X000 Part first added at this serial number
00X Part removed after this serial number

FIGURE AND INDEX NUMBERS

Items in this section are referenced by figure and index numbers to the illustrations.

INDENTATION SYSTEM

This mechanical parts list is indented to indicate item relationships. Following is an example of the indentation system used in the description column.

```

1 2 3 4 5           Name & Description
Assembly and/or Component
Attaching parts for Assembly and/or Component
    --- * ---
Detail Part of Assembly and/or Component
Attaching parts for Detail Part
    --- * ---
Parts of Detail Part
Attaching parts for Parts of Detail Part
    --- * ---
  
```

Attaching Parts always appear in the same indentation as the item it mounts, while the detail parts are indented to the right. Indented items are part of, and included with, the next higher indentation. The separation symbol --- * --- indicates the end of attaching parts.

Attaching parts must be purchased separately, unless otherwise specified.

ITEM NAME

In the Parts List, an Item Name is separated from the description by a colon (:). Because of space limitations, an Item Name may sometimes appear as incomplete. For further Item Name identification, the U.S. Federal Cataloging Handbook H6-1 can be utilized where possible.

ABBREVIATIONS

#	INCH	ELCTRN	ELECTRON	IN	INCH	SE	SINGLE END
ACTR	NUMBER SIZE	ELEC	ELECTRICAL	INCAND	INCANDESCENT	SECT	SECTION
ADPTR	ACTUATOR	ELCTLT	ELECTROLYTIC	INSUL	INSULATOR	SEMICON	SEMICONDUCTOR
ALIGN	ADAPTER	ELEM	ELEMENT	INTL	INTERNAL	SHLD	SHIELD
AL	ALIGNMENT	EPL	ELECTRICAL PARTS LIST	LPHLDR	LAMPHOLDER	SHLDR	SHOULDERED
ASSEM	ALUMINUM	EQPT	EQUIPMENT	MACH	MACHINE	SKT	SOCKET
ASSY	ASSEMBLED	EXT	EXTERNAL	MECH	MECHANICAL	SL	SLIDE
ATTEN	ASSEMBLY	FIL	FILLISTER HEAD	MTG	MOUNTING	SLFLKG	SELF-LOCKING
AWG	ATTENUATOR	FLEX	FLEXIBLE	NIP	NIPPLE	SLVG	SLEEVING
BD	AMERICAN WIRE GAGE	FLH	FLAT HEAD	NON WIRE	NOT WIRE WOUND	SPR	SPRING
BRKT	BOARD	FLTR	FILTER	OBD	ORDER BY DESCRIPTION	SQ	SQUARE
BRS	BRACKET	FR	FRAME or FRONT	OD	OUTSIDE DIAMETER	SST	STAINLESS STEEL
BRZ	BRASS	FSTNR	FASTENER	OVH	OVAL HEAD	STL	STEEL
BSHG	BRONZE	FT	FOOT	PH BRZ	PHOSPHOR BRONZE	SW	SWITCH
CAB	BUSHING	FXD	FIXED	PL	PLAIN or PLATE	T	TUBE
CAP	CABINET	GSKT	GASKET	PLSTC	PLASTIC	TERM	TERMINAL
CER	CAPACITOR	HDL	HANDLE	PN	PART NUMBER	THD	THREAD
CHAS	CERAMIC	HEX	HEXAGON	PNH	PAN HEAD	THK	THICK
CKT	CHASSIS	HEX HD	HEXAGONAL HEAD	PWR	POWER	TNSN	TENSION
COMP	CIRCUIT	HEX SOC	HEXAGONAL SOCKET	RCPT	RECEPTACLE	TPG	TAPPING
CONN	COMPOSITION	HLCPS	HELICAL COMPRESSION	RES	RESISTOR	TRH	TRUSS HEAD
COV	CONNECTOR	HLEXT	HELICAL EXTENSION	RGD	RIGID	V	VOLTAGE
CPLG	COVER	HV	HIGH VOLTAGE	RLF	RELIEF	VAR	VARIABLE
CRT	COUPLING	IC	INTEGRATED CIRCUIT	RTNR	RETAINER	W/	WITH
DEG	CATHODE RAY TUBE	ID	INSIDE DIAMETER	SCH	SOCKET HEAD	WSHR	WASHER
DWR	DEGREE	IDNT	IDENTIFICATION	SCOPE	OSCILLOSCOPE	XFMR	TRANSFORMER
	DRAWER	IMPLR	IMPELLER	SCR	SCREW	XSTR	TRANSISTOR

CROSS INDEX—MFR. CODE NUMBER TO MANUFACTURER

Mfr. Code	Manufacturer	Address	City, State, Zip
00779	AMP, INC.	P O BOX 3608	HARRISBURG, PA 17105
01295	TEXAS INSTRUMENTS, INC., SEMICONDUCTOR GROUP	P O BOX 5012, 13500 N CENTRAL EXPRESSWAY	DALLAS, TX 75222
08261	SPECTRA-STRIP CORP.	7100 LAMPSON AVE.	GARDEN GROVE, CA 92642
13257	AMERACE, LTD.	10 ESNA PARK DRIVE	MARKHAM, ONTARIO, CANADA
22526	BERG ELECTRONICS, INC.	YOKU EXPRESSWAY	NEW CUMBERLAND, PA 17070
80009	TEKTRONIX, INC.	P O BOX 500	BEAVERTON, OR 97077
82647	TEXAS INSTRUMENTS, INC., CONTROL PRODUCTS DIV.	34 FOREST ST.	ATTLEBORO, MA 02703
83385	CENTRAL SCREW CO.	2530 CRESCENT DR.	BROADVIEW, IL 60153
86445	PENN FIBRE AND SPECIALTY CO., INC.	2032 E. WESTMORELAND ST.	PHILADELPHIA, PA 19134
87308	N. L. INDUSTRIES, INC., SOUTHERN SCREW DIV.	P. O. BOX 1360	STATESVILLE, NC 28677

<http://www.ebaman.com>

Fig. & Index No.	Tektronix Part No.	Serial/Model No. Eff Dscont	Qty	1 2 3 4 5	Name & Description	Mfr Code	Mfr Part Number
1-1	337-1064-09		1		SHIELD,ELEC:LEFT SIDE	80009	337-1064-09
-2	333-2238-00		1		PANEL,FRONT:	80009	333-2238-00
-3	348-0235-00		2		SHLD GSKT,ELEC:4.734 INCH LONG	80009	348-0235-00
-4	-----		1		CKT BOARD ASSY:FRONT PANEL(SEE A5000 EPL) (ATTACHING PARTS)		
-5	211-0116-00		4		SCR,ASSEM WSHR:4-40 X 0.312 INCH,PNH BRS - - - * - - -	83385	OBD
	-----		-		. CKT BOARD ASSY INCLUDES:		
-6	263-0019-00		2		. SWITCH PB ASSY:MOMENTARY	80009	263-0019-00
-7	388-5253-00		2		. CKT BOARD:SWITCH MODULE	80009	388-5253-00
-8	361-0814-00		4		. SPACER,CKT CARD:	80009	361-0814-00
-9	131-0608-00		50		. TERMINAL,PIN:0.365 L X 0.25 PH,BRZ,GOLD PL	22526	47357
-10	386-1447-84		1		SUBPANEL,FRONT: (ATTACHING PARTS)	80009	386-1447-84
-11	213-0192-00		4		SCR,TPG,THD FOR:6-32 X 0.50 INCH,PNH STL - - - * - - -	87308	OBD
-12	-----		1		CKT BOARD ASSY:LOG SWEEP(SEE A5400 EPL) (ATTACHING PARTS)		
-13	211-0116-00		4		SCR,ASSEM WSHR:4-40 X 0.312 INCH,PNH BRS - - - * - - -	83385	OBD
	-----		-		. CKT BOARD ASSY INCLUDES:		
-14	136-0252-04		27		. SOCKET,PIN TERM:0.188 INCH LONG	22526	75060
-15	131-0608-00		45		. TERMINAL,PIN:0.365 L X 0.25 PH,BRZ,GOLD PL	22526	47357
-16	214-0579-00		3		. TERM.,TEST PT:BRS CD PL	80009	214-0579-00
-17	136-0514-00		2		. SOCKET,PLUG IN:MICROCIRCUIT,8 CONTACT	82647	C93-08-18
-18	136-0269-02		4		. SOCKET,PLUG-IN:14 CONTACT,LOW CLEARANCE	01295	C95140
-19	136-0260-02		10		. SOCKET,PLUG-IN:16 CONTACT,LOW CLEARANCE	82647	C9316-18
-20	131-0707-00		2		. CONNECTOR,TERM.:22-26 AWG,BRS& CU BE GOLD	22526	47439
-21	352-0169-05		1		. CONN BODY,PL,EL:2 WIRE GREEN	80009	352-0169-05
-22	129-0236-01		4		SPACER,POST:0.325 L,W/4-40 EXT THD ONE END	80009	129-0236-01
-23	211-0001-00		2		SCREW,MACHINE:2-56 X 0.25 INCH,PNH STL	83385	OBD
-24	407-1878-00		1		BRACKET,ANGLE:ALUMINUM (ATTACHING PARTS)	80009	407-1878-00
-25	211-0529-00		1		SCREW,MACHINE:6-32 X 1.25 INCHES,PNH STL - - - * - - -	83385	OBD
-26	200-2060-00		1		COVER, TOP: (ATTACHING PARTS)	80009	200-2060-00
-27	211-0007-00		10		SCREW,MACHINE:4-40 X 0.188 INCH,PNH STL - - - * - - -	83385	OBD
-28	441-1352-00		1		CHAS,PL-IN UNIT:CIRCUIT CARDS (ATTACHING PARTS)	80009	441-1352-00
-29	211-0025-00		6		SCREW,MACHINE:4-40 X 0.375 100 DEG,FLH STL - - - * - - -	83385	OBD
-30	-----		1		CKT BOARD ASSY:MNFRM INTFC(SEE A5250 EPL)		
-31	131-0827-00		10		. CONTACT,ELEC:0.55 INCH LONG	22526	47349
-32	131-0608-00		45		. TERMINAL,PIN:0.365 L X 0.25 PH,BRZ,GOLD PL	22526	47357
-33	351-0217-01		1		GUIDE,CKT CARD:PLASTIC (ATTACHING PARTS)	80009	351-0217-01
-34	220-0557-00		4		NUT,SLEEVE:6-32 X 0.204 OD X 0.118 L BRS	80009	220-0557-00
-35	211-0507-00		4		SCREW,MACHINE:6-32 X 0.312 INCH,PNH STL - - - * - - -	83385	OBD
-36	386-3636-00		1		PANEL,REAR: (ATTACHING PARTS)	80009	386-3636-00
-37	213-0192-00		2		SCR,TPG,THD FOR:6-32 X 0.50 INCH,PNH STL	87308	OBD
-38	210-0589-00		2		NUT,SELF LKG HE:4-40 X 0.250 INCH	13257	22 NM-40
-39	210-1160-00		2		WASHER,NONMETAL:0.109 ID X 0.25 INCH OD	86445	OBD
-40	211-0012-00		2		SCREW,MACHINE:4-40 X 0.375 INCH,PNH STL - - - * - - -	83385	OBD
-41	426-1343-00		1		FR SECT,PLUG-IN:TOP	80009	426-1343-00
-42	426-1344-00		1		FR SECT,PLUG-IN:BOTTOM	80009	426-1344-00
-43	-----		1		CKT BOARD ASSY:OPTION INTFC(SEE A5290 EPL)		
-44	131-1425-00		1		. CONTACT SET,ELEC:R ANGLE,0.150" L,STR OF 36	22526	65521-136
	198-3420-00		1		WIRE SET,ELEC:	80009	198-3420-00
-45	175-0860-00		FT		. WIRE,ELECTRICAL:5 WIRE RIBBON	08261	SS-0522-1910610C
-46	175-0859-00		FT		. WIRE,ELECTRICAL:6 WIRE RIBBON	08261	SS-0622-1910610C

Replaceable Mechanical Parts—7L5 Option 21

Fig. & Index No.	Tektronix Part No.	Serial/Model No. Eff	Dscont	Qty	1	2	3	4	5	Name & Description	Mfr Code	Mfr Part Number
1-47	175-0858-00			FT	.					WIRE,ELECTRICAL:7 WIRE RIBBON	08261	SS-0722-1910610C
-48	175-0831-00			FT	.					WIRE,ELECTRICAL:8 WIRE RIBBON	08261	0BD
-49	131-0707-00			60	.					CONNECTOR,TERM.:22-26 AWG,BRS& CU BE GOLD	22526	47439
	131-0512-02			2	.					CONTACT,ELEC:0.315 INCH LONG	00779	61491-1
-50	352-0161-06			1	.					CONN BODY,PL,EL:3 WIRE BLUE	80009	352-0161-06
-51	352-0163-01			1	.					CONN BODY,PL,EL:5 WIRE BROWN	80009	352-0163-01
	352-0163-05			1	.					CONN BODY,PL,EL:5 WIRE GREEN	80009	352-0163-05
-52	352-0164-00			1	.					CONN BODY,PL,EL:6 WIRE BLACK	80009	352-0164-00
	352-0164-04			1	.					CONN BODY,PL,EL:6 WIRE YELLOW	80009	352-0164-04
	352-0164-06			1	.					CONN BODY,PL,EL:6 WIRE BLUE	80009	352-0164-06
-53	136-0503-00			1	.					CONN,RCPT,ELEC:16 PIN,DIP	08261	SS-800-034
-54	352-0165-01			1	.					CONN BODY,PL,EL:7 WIRE BROWN	80009	352-0165-01
	352-0165-03			1	.					CONN BODY,PL,EL:7 WIRE ORANGE	80009	352-0165-03
-55	352-0166-01			1	.					CONN BODY,PL,EL:8 WIRE BROWN	80009	352-0166-01
	352-0166-02			1	.					CONN BODY,PL,EL:8 WIRE RED	80009	352-0166-02

<http://www.ebaman.com>

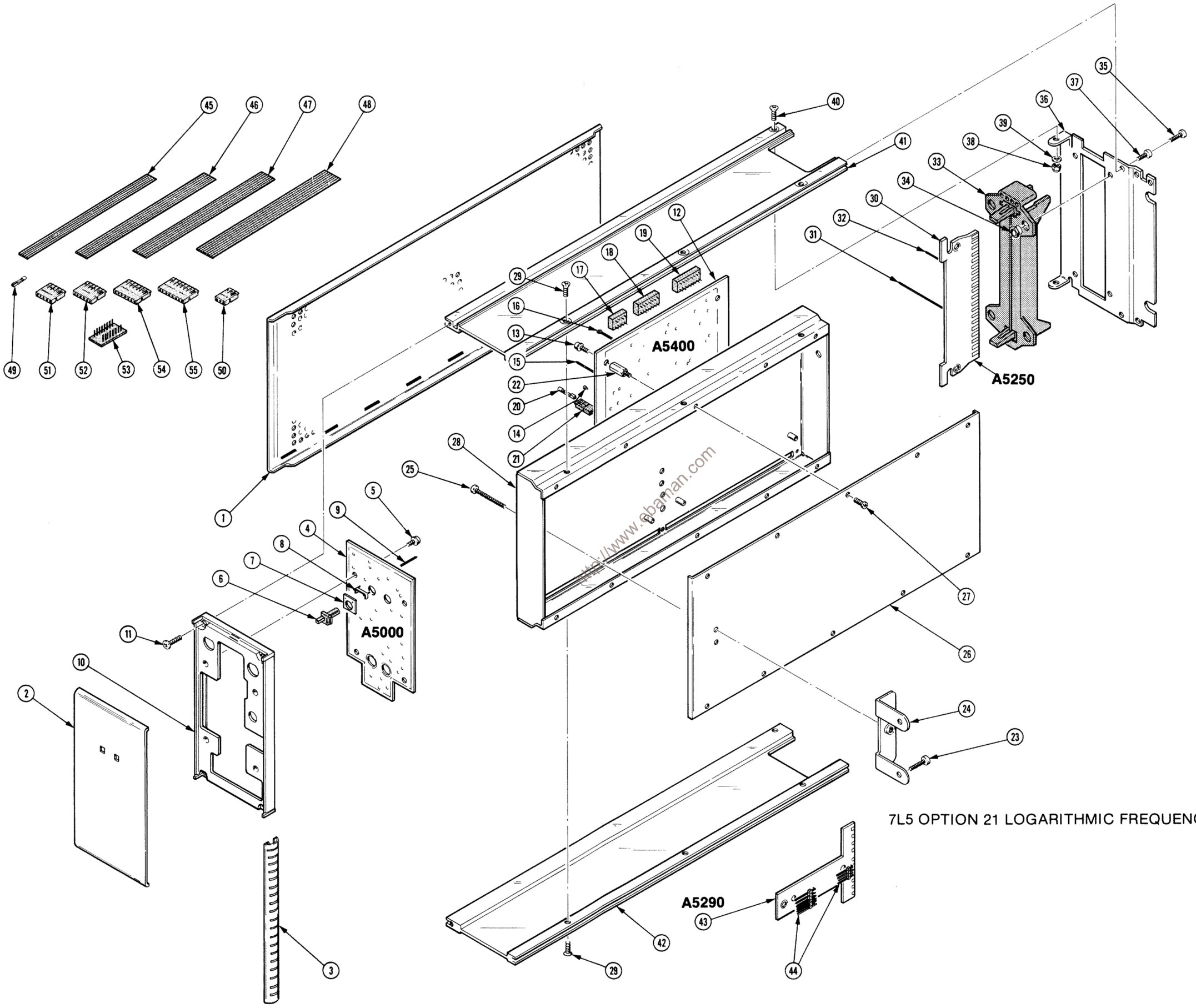

7L5 OPTION 21 LOGARITHMIC FREQUENCY DISPLAY

IRIG LOG GRATICULE FOR 7L5 opt. 21

Cut out and mount with clear tape between faceplate and CRT.

CUT ON OUTER OUTLINE FOR USM 281C.
CUT ON INNER (DOTTED) OUTLINE FOR
7704A, 7B44, 7904, 7903.

USE FOR 7603 MAINFRAME.

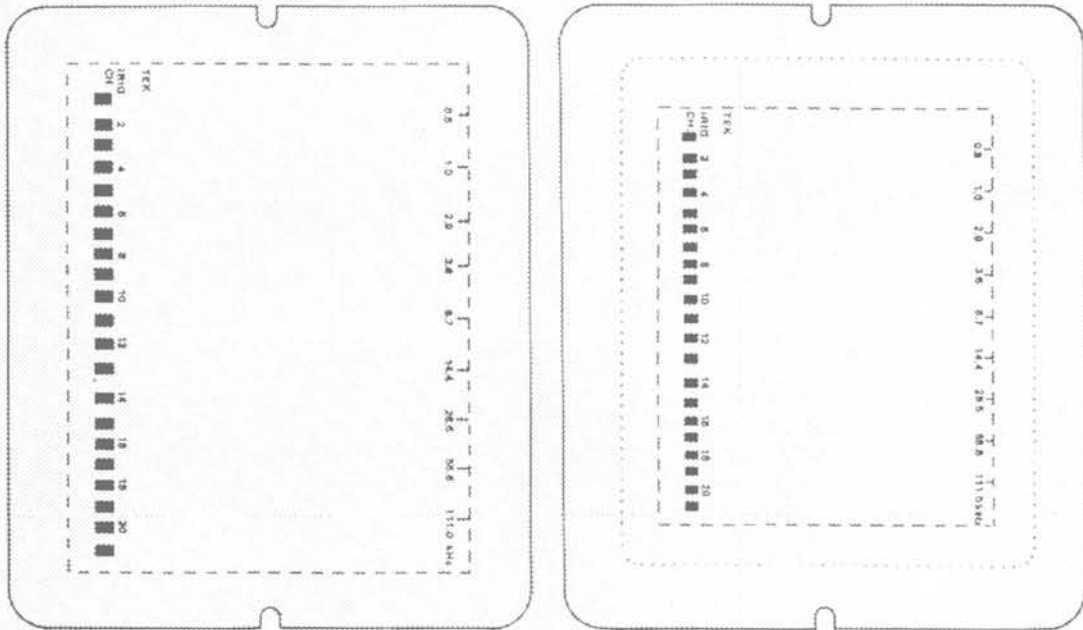

331-0421-00

<http://www.ebaman.com>

Fig. & Index No.	Tektronix Part No.	Serial/Model No. Eff	Dscnt	Qty						Name & Description	Mfr Code	Mfr Part Number
					1	2	3	4	5			
-1	331-0421-00			1						SCALE, CRT: CLEAR PLASTIC	80009	331-0421-00
	070-2155-03			1						MANUAL, TECH: INSTRUCTION	80009	070-2155-03

7L5 OPTION 25

Tracking Generator

GENERAL INFORMATION

Introduction

The 7L5 with Option 25 is a spectrum analyzer with a tracking generator. The Option 25 tracking generator is a single wide unit that attaches to the left side of the 7L5. It provides a 10 Hz to 5.0 MHz signal source that tracks the tuned input frequency of the spectrum analyzer. Output Level and impedance of the tracking generator are selectable. Output level is: 0 to -63 dBm at 50Ω ; -6 dBm

to -69 dBm at 75Ω ; or -17 dBm to -80 dBm at 600Ω . When the analyzer/tracking generator is used in 0 span, the stability of the system is 10 Hz or better. Flatness is within 1.0 dB peak-to-peak for the system, with the 50Ω and 75Ω plug-in modules, and within 1.25 dB with 600Ω impedance.

An AUXiliary OUTPUT is provided to drive a frequency counter. Using a counter increases frequency measurement accuracy.

<http://www.ebaman.com>

TABLE OF CONTENTS

SECTION		Page
SECTION 1	SPECIFICATIONS	
	Electrical Characteristics	1-1
	Environmental Characteristics	1-1
	Accessories	1-1
SECTION 2	OPERATING INSTRUCTIONS	
	Introduction	2-1
	Function of Controls and Connectors	2-1
	Operational Check and Calibration	2-1
	1. Preliminary	2-1
	2. Check Readout	2-1
	3. Calibrate the Display	2-2
	4. Check System Flatness	2-2
	5. Check Dynamic Range	2-2
	6. Check Output Level	2-2
	7. Check Output Level Range	2-2
	8. Check AUX OUT Amplitude	2-3
	9. Check Residual FM	2-3
	10. Tracking Adjust	2-3
	11. Measuring Frequency	2-3
SECTION 3	PERFORMANCE CHECK	
	Introduction	3-1
	Equipment Required	3-1
	1. Preliminary Preparation	3-1
	2. Check Output Level and Flatness	3-1
	3. Check Spurious Suppression	3-3
	4. Check Stability	3-4
<div style="border: 1px solid black; padding: 2px; display: inline-block;">WARNING</div>		
<p>The remaining portion of this table of contents lists the servicing instructions. These servicing instructions are for use by qualified service personnel only. To avoid electric shock or other personal injury, do not perform any servicing other than that described in the operators instructions unless you are qualified to do so.</p>		
SECTION 4	CALIBRATION	
	Introduction	4-1
	Equipment Required	4-1
	1. Preliminary Preparation	4-1
	2. Calibrate the Output Level	4-1
	3. Calibrate the 3 dB Gain Step	4-1
	4. TRKG ADJ Centering	4-1
SECTION 5	CIRCUIT DESCRIPTION	
	Functional Block Description	5-1
	Detailed Description	5-1
SECTION 6	MAINTENANCE	
	Preparing the Instrument for Service	6-1
	Replacing Feedthrough Capacitors	6-1
SECTION 7	REPLACEABLE ELECTRICAL PARTS	
SECTION 8	DIAGRAMS	
SECTION 9	REPLACEABLE MECHANICAL PARTS	

CHANGE INFORMATION

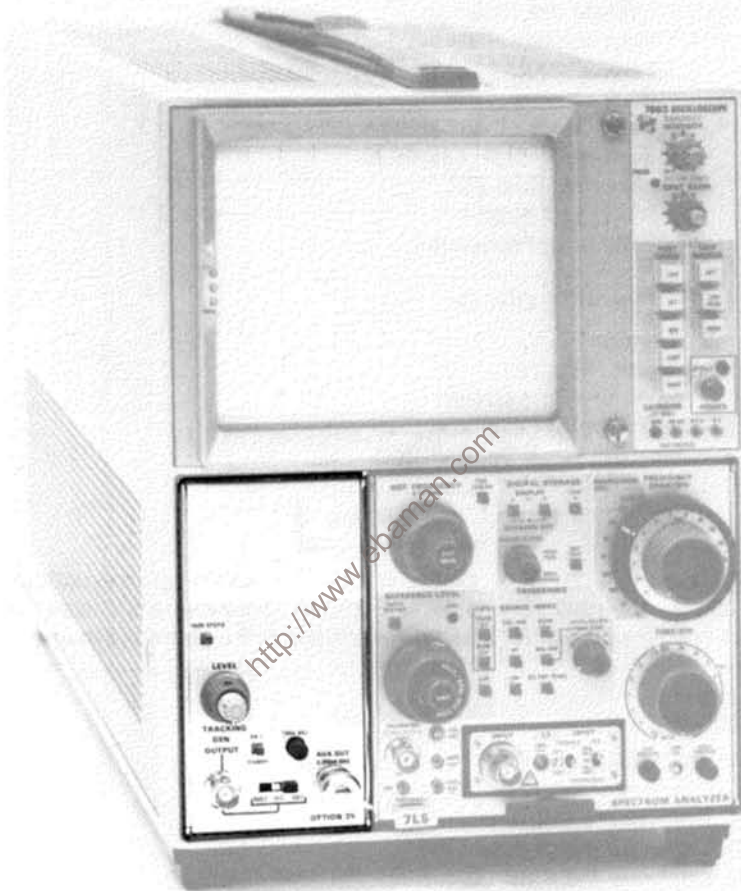

2155-13A

Fig. Option 25. 1-1. 7L5 Option 25 (Tracking Generator).

SPECIFICATIONS

ELECTRICAL CHARACTERISTICS

The following characteristics and features apply to the 7L5 Option 25 Spectrum Analyzer and Tracking Generator system. They are applicable over the environmental specification criteria for the 7000-Series mainframe.

Frequency Range: The Tracking Generator tracks the 7L5 tuned input frequency from 10 Hz to 5.0 MHz.

Output Impedance: 50 Ω , 75 Ω , or 600 Ω selected by a front panel switch.

Amplitude: The output level is calibrated in dBm or dBV and selectable in 10 dB or 1 dB steps. A vernier provides continuous variation between calibrated steps.

Range:

- 50 Ω : 0 dBm/−13 dBV to −63 dBm/−76 dBV.
- 75 Ω : −6 dBm/−17 dBV to −69 dBm/−80 dBV.
- 600 Ω : −17 dBm/−19 dBV to −80 dBm/−82 dBV.

Accuracy: (No attenuation at 500 kHz)

- 50 Ω : 0 dBm \pm (0.25 dB) or −13 dBV \pm (0.25 dB).
- 75 Ω : −6 dBm (+0.4 dB, −0.2 dB) or −17 dBV (+0.2 dB, −0.4 dB).
- 600 Ω : −17 dBm (+0.5 dB, −0.1 dB) or −19 dBV (+0.2 dB, −0.3 dB).

Attenuator:

Range: 0 to 63 dB in 10 dB or 1 dB steps.

Accuracy: Within 0.2 dB/dB to a maximum of 0.25 dB/10 dB change in output level.

Flatness:

50 Ω and 75 Ω : Within 0.5 dB peak-to-peak over full frequency range.

600 Ω : Within 1.0 dB peak-to-peak over full frequency range.

Total system flatness (7L5 with L1, L2, or L3 plug-in Module and Tracking Generator).

50 Ω and 75 Ω : Within 1.0 dB peak-to-peak.

600 Ω : Within 1.25 dB peak-to-peak.

Dynamic Range (7L5 with Option 25): \geq 110 dB.

Residual FM (peak-to-peak):

Spans to 2 kHz/Div: 2 Hz (7L5 Option 25).

Spans 5 kHz/Div or greater: 40 Hz (7L5 Option 25).

Stability: 25 Hz/5 minutes after 10 minute warmup, decreasing to 25 Hz/hr maximum after 1 hour.

Spurious Suppression, 10 Hz to 5.0 MHz (harmonic and non-harmonic): 40 dB or more down with respect to the carrier.

Auxiliary Output: \geq 200 mV rms into 50 Ω .

ENVIRONMENTAL CHARACTERISTICS

This instrument will meet the electrical characteristics over the environmental limits of the 7000-Series mainframe. Complete details on test procedure, including failure criteria, etc., can be obtained from Tektronix, Inc. Contact your local Tektronix Field Office or representative.

Operating and Storage Requirements

Operating Temperature Range: 0°C to +55°C.

Storage Temperature Range: −54°C to +75°C.

ACCESSORIES

Standard Accessories

Manual, Instruction
(see MPL Section 9)

OPERATING INSTRUCTIONS

Introduction

This section describes the function of front panel controls and connectors, the hookup to the spectrum analyzer and auxiliary equipment, and an instrument operational check with some basic applications. This operational check will verify instrument operation satisfactory. It can be used as an incoming inspection or check. Procedures for the verification of characteristics that require test equipment are in Section 3.

The Tracking Generator (Option 25) provides a constant, level-calibrated, rf signal source that precisely tracks the spectrum analyzer input frequency from 10 Hz to 5.0 MHz. The output level is calibrated and adjustable from 0 dBm to -63 dBm at 50 Ω , -6 dBm to -69 dBm at 75 Ω , and -17 dBm to -80 dBm at 600 Ω . Dynamic range is 110 dB or greater. The 7L5 Option 25 system is a high resolution, high dynamic range, network analyzer that is useful for analyzing the performance of such devices as: crystal filters, amplifiers, etc. Accurate frequency measurements of any fixed position of span can be made by connecting a frequency counter to the AUX OUT.

Applications for tracking generator/spectrum analyzer systems are described in Tektronix booklet No. AX-3281. These can be obtained from your local Tektronix Field Office or representative.

Function of Controls and Connectors

10 dB STEPS: Selects 10 dB (when illuminated) or 1 dB (not illuminated) steps of attenuation for the output LEVEL control.

LEVEL: Selects a calibrated output level of 0 dBm to -63 dBm at 50 Ω , -6 dBm to -69 dBm at 75 Ω , and -17 dBm to -80 dBm at 600 Ω , in 10 dB or 1 dB steps, as selected by the 10 dB STEPS switch.

VAR: This control, with its range of 2 dB or better, provides continuous output level adjustment between each position of the LEVEL control.

TRACKING GEN OUTPUT: Selects 50 Ω , 75 Ω , or 600 Ω terminated output impedance.

TRACK ADJ: Adjusts the Tracking Generator output signal frequency to the tuned input frequency of the spectrum analyzer.

ON/STANDBY: Enables Tracking Generator when selected, disables oscillators when in standby (not illuminated) mode.

Output Connectors

TRACKING GEN OUTPUT: This is a calibrated 63 dB dynamic range signal source, with a selectable internal impedance of 50 Ω , 75 Ω , or 600 Ω , and a frequency that tracks the spectrum analyzer. Output level depends on the setting of the LEVEL and VAR controls plus the impedance selected by the output impedance switch. The selected output impedance does not affect the output level from the AUX OUT.

AUX OUT: A 200 mV (rms) or better, 50 Ω signal for auxiliary test equipment, such as a frequency counter. Output is 200 mV (rms) or better when the VARIABLE control is in its Cal (fully ccw) position.

OPERATIONAL CHECK AND CALIBRATION

1. Preliminary

a. Install the 7L5 Option 25 in a 7000-Series mainframe with readout. Set the front panel controls as follows:

FREQUENCY SPAN/DIV	MAX
RESOLUTION	COUPLED
TIME/DIV	AUTO
VAR (Reference Level)	Cal detent (fully cw)
dBm/dBV	dBm

b. Switch the mainframe power on and allow approximately 5 minutes for the instrument to warmup.

2. Check Readout

a. When voltage comes up, the initial readout for the 7L5 and Tracking Generator should be:

7L5 Reference Level	+17 or +16 dBm (50 Ω), +6 dBm (600 Ω)
Tracking Generator Output	0 dBm (50 Ω), -6 dBm (75 Ω) -17 dBm (600 Ω)

b. Switch the 7L5 plug-in module dBm/dBV selector to dBV. Check the Tracking Generator Output Level readout for: -13 dBV (50 Ω), -17 dBV (75 Ω), and -19 dBV (600 Ω).

Operating Instructions—7L5 Option 25

NOTE

$$dBV = [dBm (50 \Omega) - 13 dB] = [dBm (75 \Omega) - 11 dB] = [dBm (600 \Omega) - 2 dB]$$

c. Switch the VARIable control out of its Cal detent. Note, the < symbol that prefixes the output level readout. Return the VARIable control to its Cal detent and set the LEVEL for 0 dBm (50 Ω).

3. Check Calibration

Calibrate the 7L5 display as described under Initial Calibration in the Operating Instructions of the 7L5 Operators manual. Using the appropriate coaxial cable for the input impedance of the plug-in module, connect the TRACKING GEN OUTPUT to the INPUT of the L-Series plug-in module (e.g., 50 Ω coaxial cable for L1 plug-in module).

If a frequency counter is used, connect the AUX OUT through a 50 Ω coaxial cable to the counter input.

4. Check System Flatness

a. Set the front panel controls as follows:

7L5	
SPAN/DIV	MAX
RESOLUTION	COUPLED
TIME/DIV	AUTO
DOT FREQUENCY	500.00 kHz
Display Mode	2 dB/Div
REFERENCE LEVEL	2 dBm (calibrated)
Triggering	FREE RUN and NORM
Digital Storage	DISPLAY A and DISPLAY B
Video Cursor	Fully cw (off screen)

Tracking Generator

ON/STANDBY	ON
10 dB STEPS	On
LEVEL	0 dBm (50 Ω)

b. Observe system flatness. The display should be a horizontal line about one division below the top graticule line. Maximum peak-to-peak deviation should not exceed 1 dB (0.5 division) for 50 Ω and 75 Ω impedances and 1.25 dB for 600 Ω output. Disregard the spectrum analyzer 0 Hz spur at the left edge of the display.

5. Check Dynamic Range

a. Change the 7L5 REFERENCE LEVEL to -50 dBm, RESOLUTION to 10 Hz, SPAN/DIV to 0, and switch the Digital Storage off. Set the Tracking Generator output LEVEL to -60 dBm.

b. Adjust the TRKG ADJ control for maximum output level (maximum beam vertical deflection).

c. Change the RESOLUTION to 1 kHz, SPAN/DIV to MAX, Display Mode to 10 dB/DIV, and switch the Digital Storage (DISPLAY A and DISPLAY B) on. Change the Tracking Generator output LEVEL to 0 dBm.

d. Remove the coaxial cable between the INPUT connector of the plug-in module and the Tracking Generator. Install 50 Ω terminators on the TRACKING GEN OUTPUT and plug-in module INPUT.

e. Note the noise level floor. Noise floor must equal or exceed -110 dBm (60 dB below REFERENCE LEVEL of -50 dBm).

6. Check Output Level

a. Set the Tracking Generator Output impedance to the input impedance of the 7L5 plug-in module and connect the TRACKING GEN OUTPUT through an appropriate cable to the INPUT of the plug-in module. Set the Display Mode to 2 dB/DIV, DOT FREQUENCY to 500.00 kHz, SPAN/DIV to 2 kHz and RESOLUTION to 30 kHz.

b. Set the Tracking Generator Output LEVEL to maximum 0 dBm (50 Ω), -6 dBm (75 Ω), or -17 dBm/-19 dBV (600 Ω) and the REFERENCE LEVEL (for the 7L5) 2 dB higher than the Tracking Generator output level.

c. Check output level.

7. Check Output Level Range (≥ 63 dB)

a. With the Tracking Generator OUTPUT applied to the 7L5 INPUT, set the output LEVEL for maximum and the 7L5 REFERENCE LEVEL to that of the Tracking Generator (e.g., 0 dBm at 50 Ω). Set the Display Mode to 10 dB/DIV.

b. Switch the Tracking Generator 10 dB STEPS on and decrease the output LEVEL 60 dB in 10 dB steps.

c. Decrease the 7L5 REFERENCE LEVEL 60 dB and switch the Display Mode to 2 dB/DIV.

d. Switch the Tracking Generator 10 dB STEPS off and decrease the output level to minimum. Output level should decrease an additional 3 dB for a total range of 63 dB.

e. Check the VARIable LEVEL control range by rotating it through its range and noting that the output level decreases at least another 1 dB to provide continuous output level adjustment over the 63 dB range.

8. Check AUX OUT Amplitude

a. Switch the 7L5 Display Mode to LIN and set the REFERENCE LEVEL to 100 mV.

b. Switch the Tracking Generator LEVEL to 0 dBm and set the VARIable control in its Cal detent (fully ccw).

c. Connect the AUX OUT to the INPUT of a 50 Ω plug-in module and terminate the TRACKING GEN OUTPUT into a 50 Ω termination.

d. Check the Auxiliary Output level for 200 mV or more display amplitude (2 divisions or more).

9. Check Residual FM (Equal to or less than 2 Hz)

a. Set the front panel controls as follows:

DOT FREQUENCY	500.00 kHz
SPAN/DIV	50 Hz
RESOLUTION	30 Hz
Display Mode	2 dB/DIV
REFERENCE LEVEL	-40 dBV
TIME/DIV	2 s

b. Set the Tracking Generator output LEVEL to -40 dBV. Connect the 7L5 CALIBRATOR signal to the INPUT and adjust the REFERENCE LEVEL for a full 8 division display. Use SGL SWP mode to sweep the spectrum. (The response of the 7L5 30 Hz filter is approximately 3 Hz per vertical division when the amplitude is full screen.)

c. Disconnect the coaxial cable from the CALIBRATOR output and connect it to the TRACKING GEN OUTPUT so the Tracking Generator signal is applied to the INPUT.

d. Switch the Triggering to NORM then set the output level to half screen with the TRKG ADJ control.

e. Switch the Triggering to SGL SWP and observe the ripple amplitude for one sweep. Amplitude must not exceed 2/3 division or 2 Hz.

10. Tracking Adjust

This control adjusts the Tracking Generator output frequency. Its adjustment determines how near the frequency tracks the input frequency of the spectrum analyzer.

a. Set the 7L5 REFERENCE LEVEL to +10 dBm and the Tracking Generator output LEVEL to 0 dBm or maximum.

b. Decrease the 7L5 SPAN/DIV to 0 Hz and RESOLUTION to 10 Hz.

c. Slowly adjust the TRKG ADJ control for maximum display amplitude. When the display amplitude peaks, the output frequency of the Tracking Generator is tracking the input frequency of the 7L5.

11. Measuring Frequency

The VARIable LEVEL control affects the output level of the AUX OUT signal. Output also shifts in 1 dB increments, 3 dB as the LEVEL control is switched through its range.

a. Connect the AUX OUT through a 50 Ω coaxial cable to the input of a frequency counter. Set the VARIable LEVEL control at its Cal detent (fully ccw).

b. Use the spectrum analyzer in the non-sweep mode to measure frequency. As the beam is positioned across the screen with the MNL SWP control, the frequency counter will read out the frequency.

c. If desired, use the SAVE A feature to store a display by switching DISPLAY A on and off, while positioning the beam with the MNL SWP control. The frequency of various points across the display may be measured with the counter.

PERFORMANCE CHECK

Introduction

This section contains procedures to verify specification characteristics that cannot be checked by the operational check in Section 2 (Operating Instructions). These checks are more complex and require extra test equipment.

Equipment Required

a. Signal Generator (used to check output level and flatness): Frequency range, 10 Hz to 5 MHz. Output level, 0 dBm to -17 dBm. Level flatness, $\pm 0.5\%$. Output impedance, $50\ \Omega$ and $75\ \Omega$. Hewlett Packard 654A Test Oscillator.

b. Spectrum Analyzer (used to check stability): Frequency range, 10 Hz to 5 MHz. Residual FM, ≤ 1 Hz. Stability, ≤ 5 Hz/hour. Tektronix 7L5 with 7000-Series mainframe.

c. Spectrum Analyzer (used to check spurious suppression): Frequency range, 1 kHz to 15 MHz. Tektronix 7L12 or 7L13 Spectrum Analyzer and 7000-Series mainframe.

d. Two (2) BNC to banana plug adapters: Tektronix Part No. 103-0035-00.

e. Two (2) patch cord to banana plugs: Tektronix Part No. 012-0039-00.

f. Coaxial cable, $50\ \Omega$, BNC connectors, 42 inch: Tektronix Part No. 012-0076-00.

g. Coaxial cable, $75\ \Omega$, BNC connectors, 46 inch: Tektronix Part No. 012-0074-00.

1. Preliminary Preparation

Perform the Operational Check and Calibration described in the Operating Instruction section of the manual.

2. Check Output Level and Flatness

Output level: $0\ \text{dB} \pm 0.25\ \text{dB}$ at $50\ \Omega$; $-6\ \text{dBm}$, $+0.4\ \text{dB}$, $-0.2\ \text{dB}$ at $75\ \Omega$; and $-17\ \text{dBm}$, $+0.5\ \text{dB}$, $-0.1\ \text{dB}$ at $600\ \Omega$. Flatness: within $0.5\ \text{dB}$ at $50\ \Omega$ and $75\ \Omega$ and within $1.0\ \text{dB}$ at $600\ \Omega$, peak-to-peak, over full frequency range.

The basic output impedance of the Tracking Generator is $50\ \Omega$. Matching pads are used to provide the $75\ \Omega$ and $600\ \Omega$ impedances. Flatness need only be checked at one impedance, output level measurement verifies the accuracy of the matching pads and checks the specified maximum output characteristic.

This step describes the check procedure for each impedance setting, using an L3 plug-in module. The procedure is applicable for the L1 or L2. Use the internal termination of the plug-in module instead of an external terminator as described in this procedure for the L3. An accurate signal source (within $0.1\ \text{dB}$) with an output impedance of $50\ \Omega$ and $75\ \Omega$ (such as a Hewlett Packard 654A test oscillator) is required.

a. Test setup is shown in Fig. Option 25. 3-1. Set the front panel controls as follows:

7L5 (With L3 Plug-In Module)

DOT FREQUENCY	500.00 kHz
SPAN/DIV	2 kHz
RESOLUTION	30 kHz
Display Mode	2 dB/DIV
REFERENCE LEVEL	$-6\ \text{dBV}$ (approximate)
Digital Storage	DISPLAY A and DISPLAY B
TIME/DIV	AUTO
TERM Z	$1\ \text{M}\Omega$
REF	dBV

Tracking Generator

Output Impedance	$50\ \Omega$
------------------	--------------

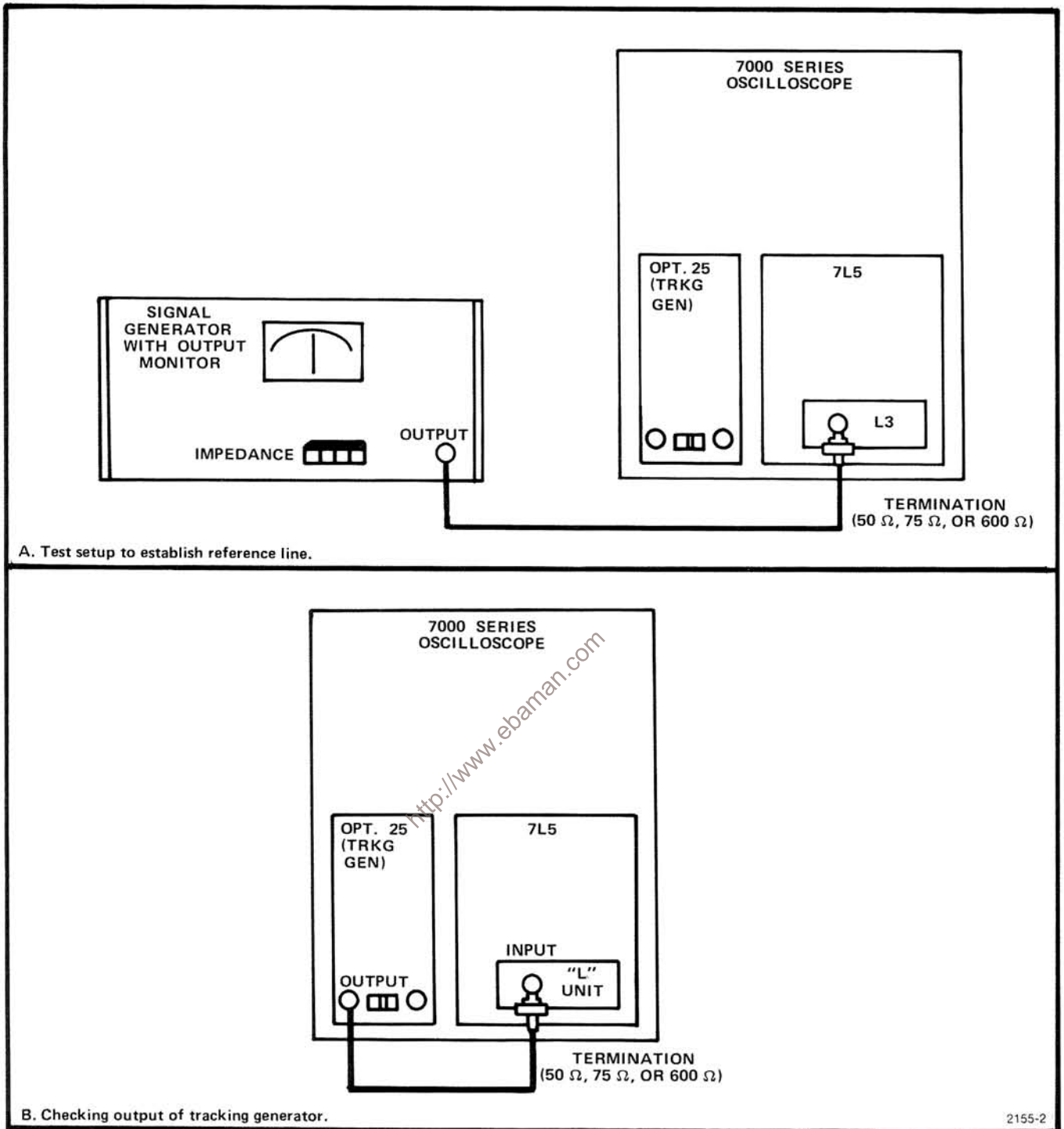

Fig. Option 25. 3-1. Test setup to check output level and flatness.

b. Apply a 0 dBm, 500 kHz signal, from 50 Ω signal source, through a 50 Ω coaxial cable and 50 Ω termination, to the INPUT of the L3 plug-in module. (If the plug-in module is an L1, use the internal termination.)

c. Adjust the signal level to a reference line on the crt graticule with the REFERENCE LEVEL control. Place the display in memory by activating SAVE A.

d. Disconnect the coaxial cable from the signal generator and connect it to the TRACKING GEN OUTPUT. Switch the Tracking Generator on.

e. Observe and compare the Tracking Generator output level to the reference signal in A memory. Output level of the Tracking Generator must be within 0.25 dB of the reference (0 dBm) signal amplitude.

f. Reconnect the generator signal through the 50 Ω termination to the INPUT of the plug-in module. Change the SPAN/DIV to 100 kHz, switch SAVE A off and activate MAX HOLD.

g. Tune the signal generator frequency slowly through the 1000 kHz span to draw a reference line across the screen (spectrum). Tuning the generator rapidly will leave holes in the line. Resweep any section that is rough.

h. Place the reference line in A memory by activating SAVE A and switch MAX HOLD off. Now disconnect the coaxial cable from the signal generator and connect it to the TRACKING GEN OUTPUT.

i. Compare the Tracking Generator flatness to the reference line stored in A memory. Flatness must be within 0.5 dB peak-to-peak of the reference.

j. Reconnect the coaxial cable to the signal generator. Switch SAVE A off and MAX HOLD on. Increase the DOT FREQUENCY to 2000.00 kHz and the SPAN/DIV to 200 kHz.

k. Now tune the signal generator through the 1.0 MHz to 3.0 MHz span to draw a reference line across the screen.

l. Save the display by activating SAVE A and switch MAX HOLD off.

m. Disconnect the coaxial cable from the signal generator and connect it to the TRACKING GEN OUTPUT as described in step h. Now, check the Tracking Generator flatness against the reference for the 1.0 MHz to 3.0 MHz range.

n. Repeat this procedure to check flatness from 3.0 MHz to 5.0 MHz.

o. Replace the 50 Ω coaxial cable and termination with a 75 Ω cable and 75 Ω termination. Apply the signal generator signal, at 75 Ω, (change generator output impedance to 75 Ω) to the INPUT of the plug in module. Set the generator output to -6 dBm/-17 dBV. Return the signal generator and 7L5 DOT FREQUENCY to 500 kHz. Set the SPAN/DIV to 2 kHz, switch SAVE A off, and MAX HOLD on. Switch the Tracking Generator output impedance to 75 Ω. Repeat the procedure described for checking the output level and flatness at 50 Ω.

p. Check the Tracking Generator output level and flatness characteristics at 600 Ω as follows:

1. Return the generator output impedance to 50 Ω. Apply a -6.2 dBm at 50 Ω signal through the 50 Ω cable and termination to the INPUT of the plug-in module. Note: -6.2 dBm at 50 Ω is equivalent to -17 dBm/-19 dBV at 600 Ω. $\text{dBV} = (\text{dBm} + 10 \log R - 30)$.

2. Establish a reference amplitude level as previously described and place it into A memory, by activating SAVE A.

3. Remove the termination and cable from the INPUT of the plug-in module. Apply the Tracking Generator OUTPUT, through BNC to banana plug adapters and patch cords, with a 600 Ω feedthrough termination (at the 7L5 input end), to the INPUT of the plug-in module.

4. Switch the Tracking Generator output impedance to 600 Ω. Compare the output level to the reference level established by the signal generator. Output level must be -19 dBV, +0.2 dB -0.3 dB.

5. Now check flatness as previously described.

3. Check Spurious Suppression (≥ 40 dB below carrier)

a. Connect the TRACKING GEN OUTPUT to the RF Input of a test spectrum analyzer (7L12 or 7L13). Set the front panel controls as follows:

7L5 Option 25

SPAN/DIV	MAX
RESOLUTION	COUPLED
TIME/DIV	1 s
Output Level	0 dBm at 50 Ω

Test Spectrum Analyzer

Reference Level	+10 dBm
Span/Div	2 MHz
Resolution	Coupled
Center Frequency	0
Display Mode	10 dB/Div

b. Check the display for spurious signals (2nd and 3rd order harmonics of the carrier) as the Tracking Generator sweeps through the 10 Hz to 5.0 MHz span. Spurious amplitude must be down 40 dB or more from the carrier.

Performance Check—7L5 Option 25

4. Check Stability (≤ 25 Hz/hour after 10 minute warmup)

a. After the 7L5 Option 25 and test spectrum analyzer have stabilized, connect the TRACKING GEN OUTPUT to the INPUT of the 7L5 Option 25. Set the front panel controls as follows:

7L5 Option 25

SPAN/DIV	0 Hz
RESOLUTION	10 Hz
TIME/DIV	AUTO
DOT FREQUENCY	500 kHz
Tracking Gen	
Output LEVEL	0 dBm at 50 Ω

Test Analyzer (7L5)

Span/Div	50 Hz
Resolution	Coupled
Dot Frequency	500 kHz
Reference Level	+10 dBm at 50 Ω
Time/Div	Auto
Digital Storage	Display A and Display B

b. Adjust the Tracking Generator tracking with the TRACKING ADJ control to the spectrum analyzer frequency.

c. Now connect the Tracking Generator Output to the Input of the test spectrum analyzer. Tune the signal to center screen then activate Max Hold.

d. Check the test spectrum analyzer display after 1 hour, and note the amount of drift. Drift must not exceed 25 Hz.

This completes the performance check. If your instrument has met the characteristics parameters, it is within specifications and ready to operate. If it is not up to specifications, refer to the Calibration Procedure or the Maintenance Section.

<http://www.ebaman.com>

WARNING

THE FOLLOWING SERVICING INSTRUCTIONS ARE FOR USE BY QUALIFIED PERSONNEL ONLY. TO AVOID PERSONAL INJURY, DO NOT PERFORM ANY SERVICING OTHER THAN THAT CONTAINED IN OPERATING INSTRUCTIONS UNLESS YOU ARE QUALIFIED TO DO SO.

CALIBRATION PROCEDURE

Introduction

This section describes adjustment procedures to calibrate the Tracking Generator. After calibration, the instrument performance should be checked in accordance to the procedure outlined in the Performance Check in Section 4. Because circuits are very stable, recalibration is usually necessary only after a component has been replaced or the instrument has been operating for a number of hours. There are only a few adjustments required to calibrate the Tracking Generator. Since it is an option to the 7L5, its performance depends on the calibration of the 7L5; therefore, ensure that the 7L5 is calibrated and performing to specifications before making any calibration adjustments to the Tracking Generator.

Equipment Required

No external test equipment is required. A non-metallic screwdriver, such as JFD Production Tool 7104-5 should be used to adjust the filter. A coaxial cable is used to connect the Tracking Generator output to the 7L5 Input.

1. Preliminary Preparation

a. Calibrate the 7L5 display as directed under Initial Calibration in the Operating Instructions for the 7L5.

2. Calibrate the Output Level

a. Set the front panel controls as follows:

7L5	
DOT FREQUENCY	500.00 kHz
SPAN/DIV	20 kHz
RESOLUTION	30 kHz
REFERENCE LEVEL	10 dBm
Display Mode	2 dB/DIV

Tracking Generator

Output LEVEL	MAX (0 dBm at 50 Ω or -6 dBm at 75 Ω)
--------------	---

b. Connect the TRACKING GEN OUTPUT through the appropriate coaxial cable to the input of the L plug-in module.

c. Use a non-metallic tuning tool to adjust the filter response with C5150, C5160, and C5165 (see Fig. Option 25. 4-1) for maximum output level.

d. Set the 7L5 REFERENCE LEVEL to the output level of the Tracking Generator (0 dBm at 50 Ω or -6 dBm at 75 Ω).

e. Calibrate the output level for a full screen display with R5140 (see Fig. Option 25. 4-1). If the level cannot be calibrated to full screen, proceed to Tracking Adjust Center R5105 (step 4) and repeat this step.

Calibration Procedure—7L5 Option 25

3. Calibrate the 3 dB Gain Step

a. Change the 7L5 REFERENCE LEVEL to +5 dBm at 50 Ω (−1 dBm at 75 Ω) and activate SAVE A.

b. Change the Tracking Generator Output LEVEL to −3 dBm (−9 dBm at 75 Ω) and the 7L5 REFERENCE LEVEL to +2 dBm (−4 dBm at 75 Ω).

c. Adjust R5145 (Fig. Option 25. 4-1) so the display level equals the reference line set in A memory (step a).

4. TRKG ADJ Center

a. Set the 7L5 RESOLUTION to 1 kHz or less and mechanically center the TRK ADJ control.

b. Center the control range of the TRKG ADJ by adjusting R5105 (Fig. Option 25.4-1) for maximum output. Decrease the RESOLUTION bandwidth while adjusting R5105. When properly centered, the TRKG ADJ control should swing the output frequency either side of the 7L5 input frequency.

This completes the calibration adjustment for the Tracking Generator.

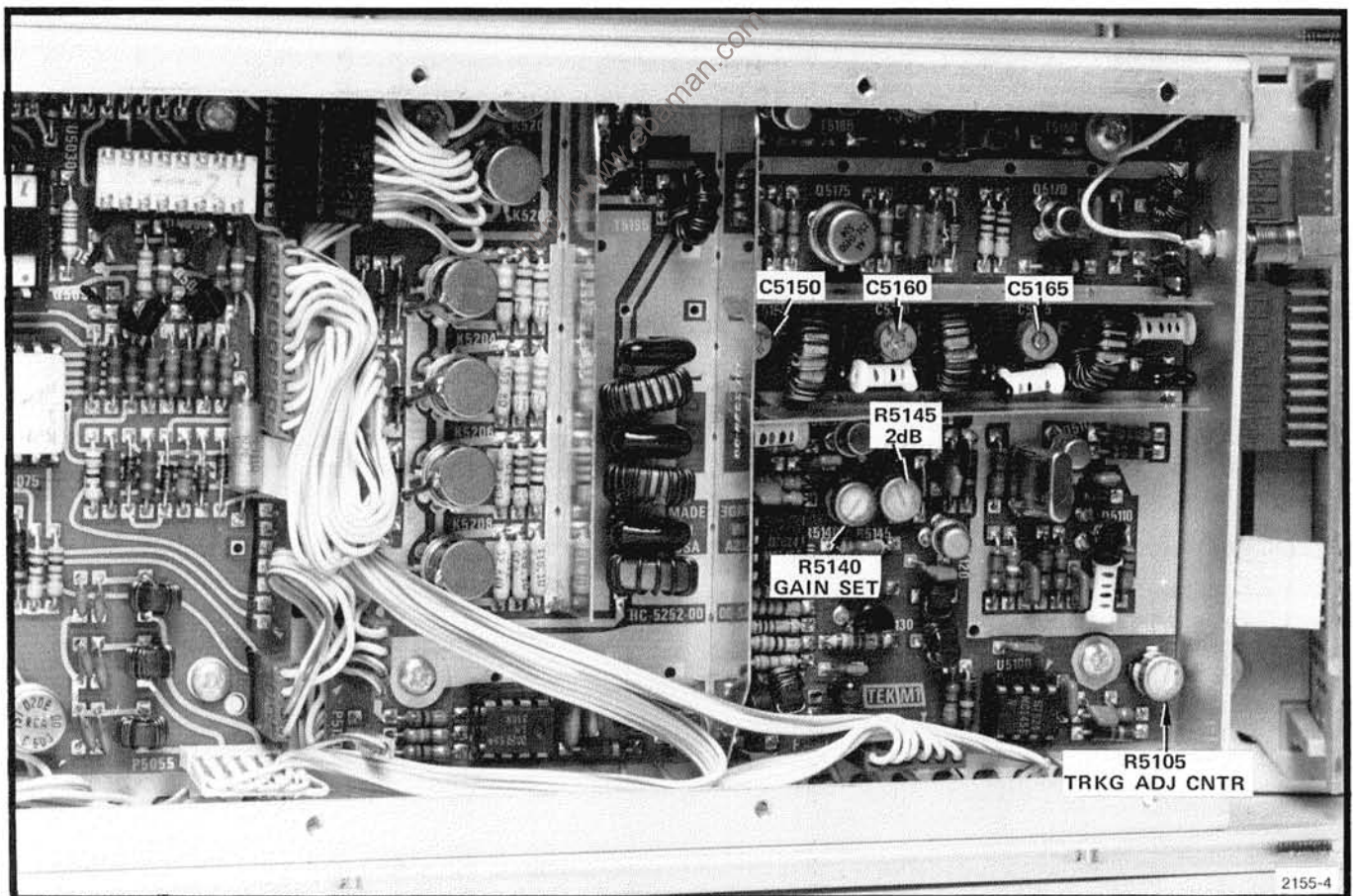

Fig. Option 25. 4-1. Adjustment location to calibrate the 7L5 Option 25 (Tracking Generator).

CIRCUIT DESCRIPTION

This section deals with the functions of major circuits and their relationship to each other. The description is general and is intended as an aid to facilitate servicing or operating the instrument to its fullest capabilities. The section starts with a block description followed with a more detailed analysis of the circuits. Diagrams may contain additional information such as waveforms, voltage data, signal levels, etc., to help understand circuit operation.

Functional Block Description

The circuitry for the Tracking Generator consists of an rf section and a logic circuit that controls output level and output impedance. The rf section converts the 7L5 1st LO output frequency (within 10.7 – 15.7 MHz) to the tuned input frequency of the 7L5 (0 to 5.0 MHz). The digital circuitry programs the output level, output impedance, and provides level readout information to the 7000-Series mainframe.

The rf section mixes a 1st LO frequency of 10.7 MHz with the 7L5 1st LO output (10.7 – 15.7 MHz), filters or blocks the upper sideband so the output lower sideband of 0 to 5.0 MHz is passed to the attenuator and impedance matching section. The 1st LO frequency can be varied about 200 Hz, either side of center, by the TRACKING ADJUST control. The 1st LO output signal level can be changed in 1 dB increments up to 3 dB by two operational amplifier gain control circuits. A front panel VARIABLE control provides continuous output level adjustment between the 1 dB steps.

The 10 MHz 1st LO signal is applied through a three stage bandpass filter to a gain of 10 dB amplifier. The resultant output signal source is 50 Ω . The 50 Ω signal is applied to one input of a double balanced mixer. The other input to the mixer is the 7L5 1st LO signal. The resultant difference frequency mixer output is then applied through a low-pass filter (to remove all but the lower side-band), a four stage attenuator (4, 8, 16, and 32 dB), and impedance matching network (50 Ω , 75 Ω , and 600 Ω) to the output connector. The output from the low-pass filter is also applied through a gain of 6 dB amplifier to the AUX OUT connector.

Output level and impedance is controlled by a digital logic circuit that functions around a Tektronix reference level control IC. The IC programs the level and output impedance of the Tracking Generator from data set by the front panel LEVEL, Output Impedance, and ON/STANDBY selectors.

Detailed Description

The incoming 7L5 1st LO signal is coupled through an isolation transformer (T5180) to the input of push-pull amplifier U5185A. The amplifier is configured for 10X gain. R5188, across the input to the amplifier, reflects 50 Ω input impedance to the 7L5 1st LO signal. The differential output from U5185A is coupled through a second isolation transformer (T5185) to drive a pair of transistors (Q5185, Q5190). The collector load for this amplifier is the primary of an input transformer to the balanced mixer. Because the amplifier (Q5185, Q5190) is overdriven, the output is a clipped waveform whose output level is greater than the 10.7 MHz 1st LO signal into the other arm of the mixer. This maintains a constant 0 to 5 MHz signal output level from the mixer.

To reduce spurs generated by crosstalk between the 10.7 MHz 1st LO and the 7L5 1st LO processing circuits, both circuits are highly decoupled.

A Butler oscillator (Q5110, Q5112) is used as the 1st LO, with its frequency controlled by a 10.7 MHz crystal, in series with Varactor diode CR5114. Frequency can be varied approximately 200 Hz each side of center by TRKG ADJ control R5000. Center frequency is set by adjustment R5105. Either adjustment changes the dc bias on diode CR5114 which changes the diode capacitance and oscillator frequency. The output is applied through emitter follower Q5120 and amplifier Q5124 to a three-pole bandpass filter.

Circuit Description—7L5 Option 25

The output amplifier (Q5125) is overdriven by emitter follower Q5120. The peak swing of the collector voltage, therefore, depends on the dc level at the output of operational amplifier U5145A. A low voltage level at the amplifier output will produce a signal swing, across resistor R5147, between the voltage level at the output of U5145A, and the collector saturation voltage of Q5125 (approximately +15 volt). The mixer output level is therefore dependent on the dc voltage level out of U5145A. This IC controls the gain in 1 dB increments from 0 to 3 dB.

The level of 10.7 MHz 1st LO signal is changed in 1 dB increments by the gain control circuit. The 1 dB and 2 dB lines, from the level decode ROM U5075, drive the negative input of operational amplifier U5145B. The output level of U5145B is inverted and amplified by operational amplifier U5145A. The output dc level controls the amplitude of the 10.7 MHz 1st LO signal. The VARIABLE control, R5005, provides continuous gain adjustment between the 1 dB steps. Gain step increments are from 0 dB down to 3 dB in 1 dB or 2 dB steps then back to 0 dB.

The three-stage bandpass filter is tuned to the fundamental 10.7 MHz signal and has a bandwidth of approximately 500 kHz. Termination impedance, for the filter is $50\ \Omega$ (set by R5170). The output of the filter feeds a buffer amplifier (Q5170, Q5175). Gain, set by the ratio of R5174 to R5172, is 10 dB. Output impedance is $50\ \Omega$ (R5178 plus the collector impedance of $7\ \Omega$).

The balanced mixer output level and impedance are dependent on the signal input to T5195 and the impedance across the transformer primary. Signal level is about 10 dB greater into T5190 than the 10.7 MHz signal into T5195. The output of the mixer feeds a three-stage low-pass filter with a flat roll-off that starts at 6 to 6.5 MHz and increases to 60 dB or more at 10.7 MHz. The output from the filter is applied through the attenuator and impedance matching network to the TRACKING GEN OUTPUT and through a buffer amplifier (U5195) to the AUX OUT connector. Gain of the buffer amplifier is 2X or 6 dB.

The $50\ \Omega$ four attenuator stage steps in 4 dB increments (4, 8, 16, and 32 dB) from 0 to 60 dB. The equivalent circuit for the three modes of the impedance matching network is shown in Fig. Option 25. 5-1.

The output level and impedance control logic circuit centers around a Tektronix MOS chip IC U5070. This IC is used in the 7L5 reference level circuit. (Refer to the 7L5 circuit description for further data.) The IC output is decoded by ROM U5075, which drives attenuator relays K5210, K5208, K5206, K5204, and the 1 dB, 2 dB gain set lines. It also provides column data current for readout. If IC U5070 should go to an illegal output level setting (e.g., +1 dBm), the decode ROM (U5075) sends this illegal setting back to another ROM which counts the level control IC back to a legal state. Offset data, to accommodate the different impedance settings and scale factor, is fed into the control IC by an impedance ROM (U5045).

The range of the output level at $50\ \Omega$ is 0 dBm to $-63\ \text{dBm}$. As described previously, IC U5070 is kept within this range by over-and-under lockout U5060 and preset ROM U5065. When the MOS IC (U5070) tries to go to an illegal address, such as 1 dBm or higher, the output at pins 10 and 11 of decode ROM U5075 enable gate U5050C. Pin 10 of U5060 is pulled low and clock pulses from the oscillator (U5020B, U5020D) are gated to counter U5060. ROM U5065 then decodes down to return U5070 to 0 dBm. When the output address of U5070 reaches 0 dBm, gate U5050C is disabled thus disabling counter U5060 and the output of the MOS IC remains steady. If the IC (U5070) tries to go below $-63\ \text{dBm}$, the output of U5075 causes the over/under counter U5060 and ROM U5065 to count. ROM U5065 then presets U5070 back to $-63\ \text{dBm}$.

Offset data for the different impedance and modes of readout are provided by ROM U5045. Impedance selector S5010 asserts a low on the input pins 10, 11, and 12 of U5045. Pins 13 and 14 are the scale factor (dBV) inputs.

The 10 dB attenuation steps and enable for the rf processing circuits, (ON/STANDBY) switch either or both of two flip-flop latches (U5010B and U5010A). The 10 dB step pushbutton, latches U5010B so the low state at the Q output, switches transistor Q5016 on to supply current for LED indicator CR5046. \bar{Q} output pulls pin 36 of U5070 high and causes it to count in 10 dB steps. The ON/STANDBY flip-flop (U5010A) latches \bar{Q} high. This turns Q5022 on. The resultant low on the collector turns on Q5020 to supply current for the LED indicator. Q5025 supplies +15 V to the rf processing circuits.

Forced readout is provided by R5072 ($51\ \Omega$), between ground and P5070-1, on the Interface circuit board. U5055 is a shift register to be used for future options.

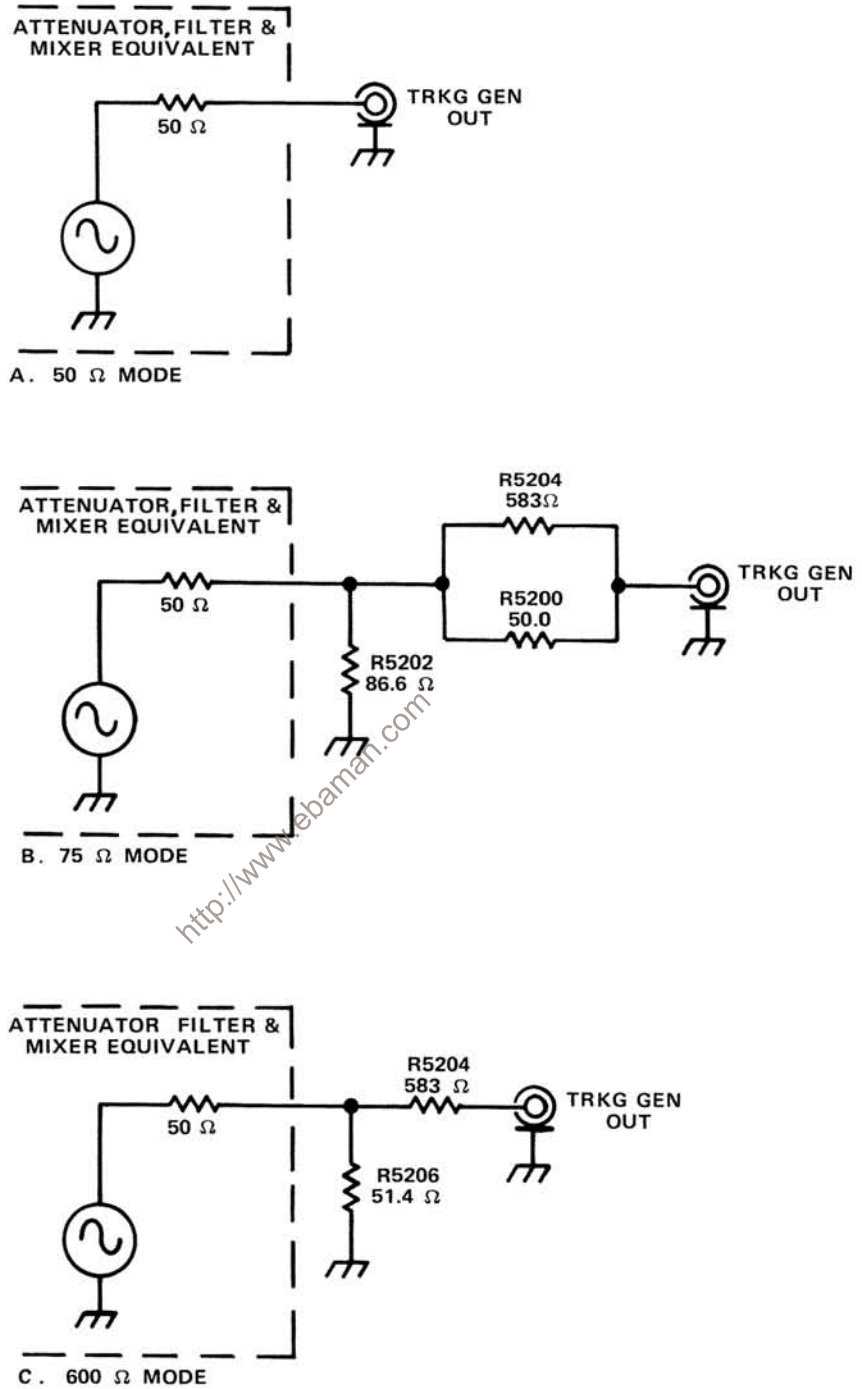

2155-5

Fig. Option 25. 5-1. Equivalent circuits of impedance matching network in each mode.

MAINTENANCE INSTRUCTIONS

Introduction

Preventive maintenance, troubleshooting techniques, and corrective maintenance procedures for the 7L5 are applicable for the Option 25 assembly. The following additional maintenance information is for the Option 25 assembly.

Preparing the Instrument for Service

1. Turn the power to the mainframe off. Remove the 7L5 Option 25 from the plug-in compartment.

2. To gain access to the Option 25 unit:

a. Remove the snap-on side panel. Loosen and remove the two screws through the back panel and the screw through the chassis cover plate to the mounting bracket on the 7L5 (see Fig. Option 25. 6-1).

b. The front of the unit should now swing out and away from the 7L5, exposing the cover plate over the Tracking Generator chassis.

c. Remove the chassis cover plate to expose the circuit boards.

d. Connect the 7L5 Option 25 through flexible plug-in extenders (Calibration Fixture No. 067-0616-00) to the mainframe interface connectors. Fig. Option 25. 6-2 illustrates a typical setup for servicing. Turn instrument power on and proceed with calibration or troubleshooting.

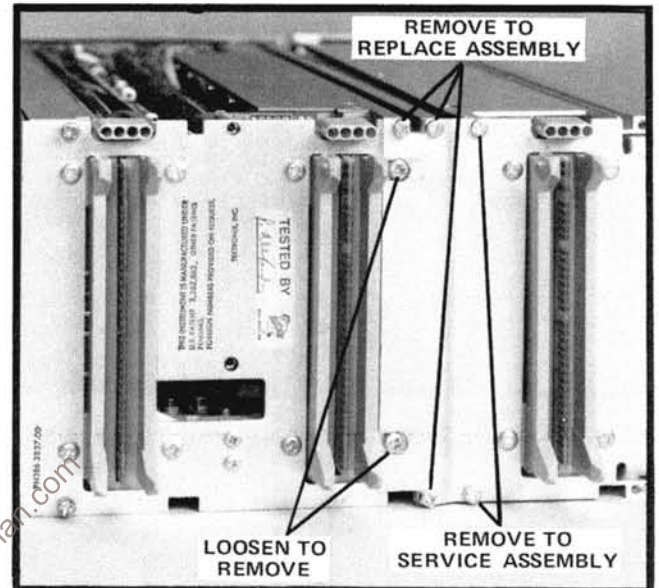

A. Location of Option assembly mounting screws.

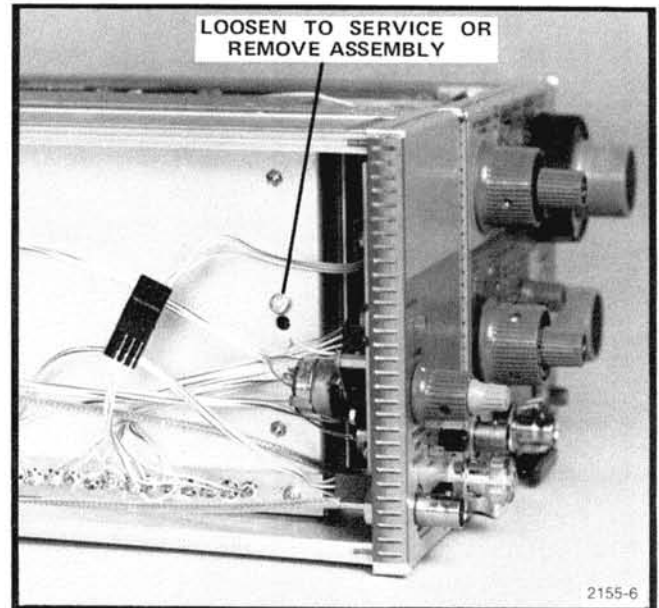

B. Location of Option assembly side panel mounting screw.

Fig. Option 25. 6-1. Location of screws that hold the Option assembly to the 7L5.

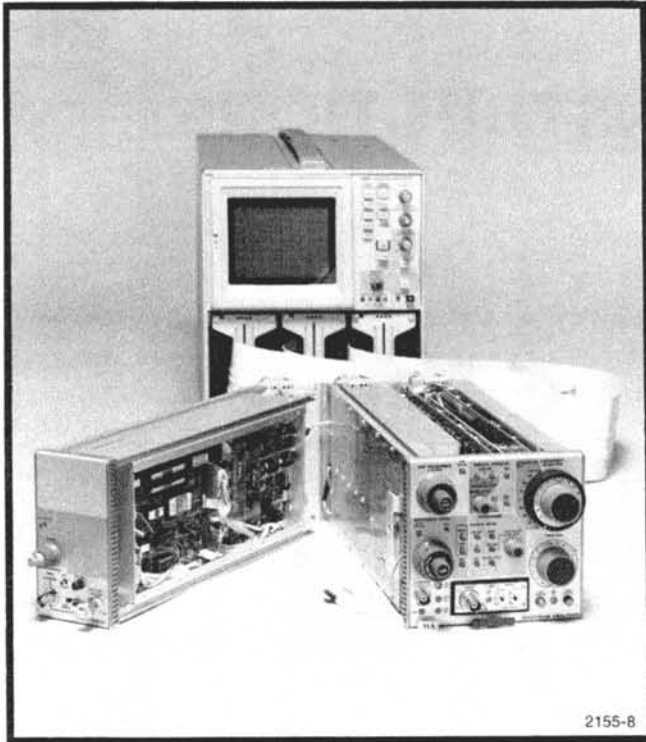

Fig. Option 25. 6-2. Typical setup for servicing the 7L5 Option 25.

<http://www.ebaman.com>

REPLACEABLE ELECTRICAL PARTS

PARTS ORDERING INFORMATION

Replacement parts are available from or through your local Tektronix, Inc. Field Office or representative.

Changes to Tektronix instruments are sometimes made to accommodate improved components as they become available, and to give you the benefit of the latest circuit improvements developed in our engineering department. It is therefore important, when ordering parts, to include the following information in your order: Part number, instrument type or number, serial number, and modification number if applicable.

If a part you have ordered has been replaced with a new or improved part, your local Tektronix, Inc. Field Office or representative will contact you concerning any change in part number.

Change information, if any, is located at the rear of this manual.

SPECIAL NOTES AND SYMBOLS

X000 Part first added at this serial number
00X Part removed after this serial number

ITEM NAME

In the Parts List, an Item Name is separated from the description by a colon (:). Because of space limitations, an Item Name may sometimes appear as incomplete. For further Item Name identification, the U.S. Federal Cataloging Handbook H6-1 can be utilized where possible.

ABBREVIATIONS

ACTR	ACTUATOR	PLSTC	PLASTIC
ASSY	ASSEMBLY	QTZ	QUARTZ
CAP	CAPACITOR	RECP	RECEPTACLE
CER	CERAMIC	RES	RESISTOR
CKT	CIRCUIT	RF	RADIO FREQUENCY
COMP	COMPOSITION	SEL	SELECTED
CONN	CONNECTOR	SEMICOND	SEMICONDUCTOR
ELCTLT	ELECTROLYTIC	SENS	SENSITIVE
ELEC	ELECTRICAL	VAR	VARIABLE
INCAND	INCANDESCENT	WW	WIREWOUND
LED	LIGHT EMITTING DIODE	XFMR	TRANSFORMER
NONWIR	NON WIREWOUND	XTAL	CRYSTAL

CROSS INDEX—MFR. CODE NUMBER TO MANUFACTURER

Mfr. Code	Manufacturer	Address	City, State, Zip
00853	SANGAMO ELECTRIC CO., S. CAROLINA DIV.	P O BOX 128	PICKENS, SC 29671
01121	ALLEN-BRADLEY COMPANY	1201 2ND STREET SOUTH	MILWAUKEE, WI 53204
02111	SPECTROL ELECTRONICS CORPORATION	17070 EAST GALE AVENUE	CITY OF INDUSTRY, CA 91745
02114	FERROXCUBE CORPORATION	PO BOX 359, MARION ROAD	SAUGERTIES, NY 12477
04713	MOTOROLA, INC., SEMICONDUCTOR PROD. DIV.	5005 E MCDOWELL RD, PO BOX 20923	PHOENIX, AZ 85036
07910	TELEDYNE SEMICONDUCTOR	12515 CHADRON AVE.	HAWTHORNE, CA 90250
28480	HEWLETT-PACKARD CO., CORPORATE HQ.	1501 PAGE MILL RD.	PALO ALTO, CA 94304
32997	BOURNS, INC., TRIMPOT PRODUCTS DIV.	1200 COLUMBIA AVE.	RIVERSIDE, CA 92507
50579	LITRONIX INC.	19000 HOMESTEAD RD.	CUPERTINO, CA 95014
56289	SPRAGUE ELECTRIC CO.		NORTH ADAMS, MA 01247
72982	ERIE TECHNOLOGICAL PRODUCTS, INC.	644 W. 12TH ST.	ERIE, PA 16512
73899	JFD ELECTRONICS COMPONENTS CORP.	PINETREE ROAD	OXFORD, NC 27565
75378	CTS KNIGHTS, INC.	400 REIMANN AVE.	SANDWICH, IL 60548
78488	STACKPOLE CARBON CO.		ST. MARYS, PA 15857
79727	C-W INDUSTRIES	550 DAVISVILLE RD., P O BOX 96	WARMINSTER, PA 18974
80009	TEKTRONIX, INC.	P O BOX 500	BEAVERTON, OR 97077
81483	INTERNATIONAL RECTIFIER CORP.	9220 SUNSET BLVD.	LOS ANGELES, CA 90069
90201	MALLORY CAPACITOR CO., DIV. OF P. R. MALLORY AND CO., INC.	3029 E. WASHINGTON STREET P. O. BOX 372	INDIANAPOLIS, IN 46206
91637	DALE ELECTRONICS, INC.	P. O. BOX 609	COLUMBUS, NE 68601

<http://www.ebaman.com>

Ckt No.	Tektronix Part No.	Serial/Model No. Eff	Dscont	Name & Description	Mfr Code	Mfr Part Number
A5000	670-4673-00			CKT BOARD ASSY:FRONT PANEL	80009	670-4673-00
A5050	670-4674-00	B010100	B059999	CKT BOARD ASSY:DIGITAL	80009	670-4674-00
A5050	670-4674-01	B060000		CKT BOARD ASSY:DIGITAL	80009	670-4674-01
A5100	670-4671-00			CKT BOARD ASSY:ANALOG	80009	670-4671-00
A5250	670-4676-00			CKT BOARD ASSY:OPTION MAIN FRAME CONNECTOR	80009	670-4676-00
A5290	670-4675-00			CKT BOARD ASSY:INTERFACE	80009	670-4675-00
C5000	281-0649-00			CAP., FXD, CER DI:1000PF, +80-20%, 500V	72982	2404039X5V102Z
C5001	281-0649-00			CAP., FXD, CER DI:1000PF, +80-20%, 500V	72982	2404039X5V102Z
C5002	281-0649-00			CAP., FXD, CER DI:1000PF, +80-20%, 500V	72982	2404039X5V102Z
C5005	281-0649-00			CAP., FXD, CER DI:1000PF, +80-20%, 500V	72982	2404039X5V102Z
C5006	281-0649-00			CAP., FXD, CER DI:1000PF, +80-20%, 500V	72982	2404039X5V102Z
C5007	281-0649-00			CAP., FXD, CER DI:1000PF, +80-20%, 500V	72982	2404039X5V102Z
C5014	283-0058-00			CAP., FXD, CER DI:0.027UF, 10%, 100V	72982	8131N147X7R0273K
C5017	281-0649-00			CAP., FXD, CER DI:1000PF, +80-20%, 500V	72982	2404039X5V102Z
C5019	281-0649-00			CAP., FXD, CER DI:1000PF, +80-20%, 500V	72982	2404039X5V102Z
C5020	283-0111-00			CAP., FXD, CER DI:0.1UF, 20%, 50V	72982	8121-N08825U104M
C5021	281-0649-00			CAP., FXD, CER DI:1000PF, +80-20%, 500V	72982	2404039X5V102Z
C5022	281-0649-00			CAP., FXD, CER DI:1000PF, +80-20%, 500V	72982	2404039X5V102Z
C5023	281-0649-00			CAP., FXD, CER DI:1000PF, +80-20%, 500V	72982	2404039X5V102Z
C5024	281-0649-00			CAP., FXD, CER DI:1000PF, +80-20%, 500V	72982	2404039X5V102Z
C5025	281-0649-00			CAP., FXD, CER DI:1000PF, +80-20%, 500V	72982	2404039X5V102Z
C5026	281-0649-00			CAP., FXD, CER DI:1000PF, +80-20%, 500V	72982	2404039X5V102Z
C5027	281-0649-00			CAP., FXD, CER DI:1000PF, +80-20%, 500V	72982	2404039X5V102Z
C5028	281-0649-00			CAP., FXD, CER DI:1000PF, +80-20%, 500V	72982	2404039X5V102Z
C5030	283-0177-00			CAP., FXD, CER DI:1UF, +80-20%, 25V	72982	8131N039 E 105Z
C5040	283-0204-00			CAP., FXD, CER DI:0.01UF, 20%, 50V	72982	8121N061Z5U0103M
C5052	283-0204-00			CAP., FXD, CER DI:0.01UF, 20%, 50V	72982	8121N061Z5U0103M
C5064	283-0111-00			CAP., FXD, CER DI:0.1UF, 20%, 50V	72982	8121-N08825U104M
C5065	283-0111-00			CAP., FXD, CER DI:0.1UF, 20%, 50V	72982	8121-N08825U104M
C5076	290-0534-00			CAP., FXD, ELCTLT: 1UF, 20%, 35V	56289	196D105X0035HA1
C5078	290-0167-00			CAP., FXD, ELCTLT: 10UF, 20%, 15V	56289	150D106X0015B2
C5080	281-0649-00			CAP., FXD, CER DI:1000PF, +80-20%, 500V	72982	2404039X5V102Z
C5090	283-0204-00			CAP., FXD, CER DI:0.01UF, 20%, 50V	72982	8121N061Z5U0103M
C5095	281-0649-00			CAP., FXD, CER DI:1000PF, +80-20%, 500V	72982	2404039X5V102Z
C5096	283-0204-00			CAP., FXD, CER DI:0.01UF, 20%, 50V	72982	8121N061Z5U0103M
C5097	281-0649-00			CAP., FXD, CER DI:1000PF, +80-20%, 500V	72982	2404039X5V102Z
C5098	283-0204-00			CAP., FXD, CER DI:0.01UF, 20%, 50V	72982	8121N061Z5U0103M
C5099	281-0649-00			CAP., FXD, CER DI:1000PF, +80-20%, 500V	72982	2404039X5V102Z
C5106	283-0204-00			CAP., FXD, CER DI:0.01UF, 20%, 50V	72982	8121N061Z5U0103M
C5108	283-0204-00			CAP., FXD, CER DI:0.01UF, 20%, 50V	72982	8121N061Z5U0103M
C5110	283-0204-00			CAP., FXD, CER DI:0.01UF, 20%, 50V	72982	8121N061Z5U0103M
C5111	281-0508-00			CAP., FXD, CER DI:12PF, +/-0.6PF, 500V	72982	301-000C0G0120J
C5114	283-0111-00			CAP., FXD, CER DI:0.1UF, 20%, 50V	72982	8121-N08825U104M
C5118	283-0111-00			CAP., FXD, CER DI:0.1UF, 20%, 50V	72982	8121-N08825U104M
C5120	283-0111-00			CAP., FXD, CER DI:0.1UF, 20%, 50V	72982	8121-N08825U104M
C5122	283-0204-00			CAP., FXD, CER DI:0.01UF, 20%, 50V	72982	8121N061Z5U0103M
C5124	283-0111-00			CAP., FXD, CER DI:0.1UF, 20%, 50V	72982	8121-N08825U104M
C5126	283-0111-00			CAP., FXD, CER DI:0.1UF, 20%, 50V	72982	8121-N08825U104M
C5127	290-0536-00			CAP., FXD, ELCTLT: 10UF, 20%, 25V	90201	TDC106M025FL
C5138	283-0204-00			CAP., FXD, CER DI:0.01UF, 20%, 50V	72982	8121N061Z5U0103M
C5146	283-0204-00			CAP., FXD, CER DI:0.01UF, 20%, 50V	72982	8121N061Z5U0103M
C5147	283-0204-00			CAP., FXD, CER DI:0.01UF, 20%, 50V	72982	8121N061Z5U0103M
C5148	281-0578-00			CAP., FXD, CER DI:18PF, 5%, 500V	72982	301-050C0G0180J
C5150	281-0158-00			CAP., VAR, CER DI:7-45PF, 50V	73899	DVJ-5006
C5152	283-0674-00			CAP., FXD, MICA D:85PF, 1%, 500V	00853	D155F850F0
C5154	281-0503-00			CAP., FXD, CER DI:8PF, +/-0.5PF, 500V	72982	301-000C0H0809D

Replaceable Electrical Parts—7L5 Option 25

Ckt No.	Tektronix Part No.	Serial/Model No. Eff	Dscont	Name & Description	Mfr Code	Mfr Part Number
C5160	281-0158-00			CAP., VAR, CER DI: 7-45PF, 50V	73899	DVJ-5006
C5162	283-0674-00			CAP., FXD, MICA D: 85PF, 1%, 500V	00853	D155F850F0
C5164	281-0503-00			CAP., FXD, CER DI: 8PF, +/-0.5PF, 500V	72982	301-000C0H0809D
C5165	281-0158-00			CAP., VAR, CER DI: 7-45PF, 50V	73899	DVJ-5006
C5166	283-0600-00			CAP., FXD, MICA D: 43PF, 5%, 500V	00853	D105E430J0
C5168	281-0540-00			CAP., FXD, CER DI: 51PF, 5%, 500V	72982	301-000U2J0510J
C5175	283-0111-00			CAP., FXD, CER DI: 0.1UF, 20%, 50V	72982	8121-N088Z5U104M
C5178	283-0204-00			CAP., FXD, CER DI: 0.01UF, 20%, 50V	72982	8121N061Z5U0103M
C5182	290-0536-00			CAP., FXD, ELCTLT: 10UF, 20%, 25V	90201	TDC106M025FL
C5184	283-0204-00			CAP., FXD, CER DI: 0.01UF, 20%, 50V	72982	8121N061Z5U0103M
C5185	283-0177-00			CAP., FXD, CER DI: 1UF, +80-20%, 25V	72982	8131N039 E 105Z
C5186	283-0204-00			CAP., FXD, CER DI: 0.01UF, 20%, 50V	72982	8121N061Z5U0103M
C5190	283-0111-00			CAP., FXD, CER DI: 0.1UF, 20%, 50V	72982	8121-N088Z5U104M
C5192	283-0598-00			CAP., FXD, MICA D: 253PF, 5%, 300V	00853	D153E2530J0
C5194	283-0594-00			CAP., FXD, MICA D: 0.001UF, 1%, 100V	00853	D151F102F0
C5196	283-0645-00			CAP., FXD, MICA D: 790PF, 1%, 100V	00853	D151E791F0
C5197	283-0330-00			CAP., FXD, CER DI: 100PF, 5%, 50V	72982	8111N068C0G0101J
C5204	283-0631-00			CAP., FXD, MICA D: 95PF, (NOM VALUE), SEL	00853	D151E950F0
C5230	283-0111-00			CAP., FXD, CER DI: 0.1UF, 20%, 50V	72982	8121-N088Z5U104M
C5232	283-0111-00			CAP., FXD, CER DI: 0.1UF, 20%, 50V	72982	8121-N088Z5U104M
C5234	283-0111-00			CAP., FXD, CER DI: 0.1UF, 20%, 50V	72982	8121-N088Z5U104M
C5236	283-0204-00			CAP., FXD, CER DI: 0.01UF, 20%, 50V	72982	8121N061Z5U0103M
C5238	290-0536-00			CAP., FXD, ELCTLT: 10UF, 20%, 25V	90201	TDC106M025FL
C5242	290-0536-00			CAP., FXD, ELCTLT: 10UF, 20%, 25V	90201	TDC106M025FL
C5246	283-0204-00			CAP., FXD, CER DI: 0.01UF, 20%, 50V	72982	8121N061Z5U0103M
C5250	281-0649-00			CAP., FXD, CER DI: 1000PF, +80-20%, 500V	72982	2404039X5V102Z
C5251	281-0649-00			CAP., FXD, CER DI: 1000PF, +80-20%, 500V	72982	2404039X5V102Z
C5252	281-0649-00			CAP., FXD, CER DI: 1000PF, +80-20%, 500V	72982	2404039X5V102Z
C5253	281-0649-00			CAP., FXD, CER DI: 1000PF, +80-20%, 500V	72982	2404039X5V102Z
C5254	281-0649-00			CAP., FXD, CER DI: 1000PF, +80-20%, 500V	72982	2404039X5V102Z
C5255	281-0649-00			CAP., FXD, CER DI: 1000PF, +80-20%, 500V	72982	2404039X5V102Z
C5256	281-0649-00			CAP., FXD, CER DI: 1000PF, +80-20%, 500V	72982	2404039X5V102Z
C5257	281-0649-00			CAP., FXD, CER DI: 1000PF, +80-20%, 500V	72982	2404039X5V102Z
C5258	281-0649-00			CAP., FXD, CER DI: 1000PF, +80-20%, 500V	72982	2404039X5V102Z
C5259	281-0649-00			CAP., FXD, CER DI: 1000PF, +80-20%, 500V	72982	2404039X5V102Z
C5260	281-0649-00			CAP., FXD, CER DI: 1000PF, +80-20%, 500V	72982	2404039X5V102Z
C5261	281-0649-00			CAP., FXD, CER DI: 1000PF, +80-20%, 500V	72982	2404039X5V102Z
C5262	281-0649-00			CAP., FXD, CER DI: 1000PF, +80-20%, 500V	72982	2404039X5V102Z
C5270	281-0697-00			CAP., FXD, CER DI: 500PF, +100-0%, 100V	80009	281-0697-00
C5271	281-0697-00			CAP., FXD, CER DI: 500PF, +100-0%, 100V	80009	281-0697-00
C5272	281-0697-00			CAP., FXD, CER DI: 500PF, +100-0%, 100V	80009	281-0697-00
CR5021	152-0141-02			SEMICONV DEVICE: SILICON, 30V, 150MA	80009	152-0141-02
CR5022	152-0075-00			SEMICONV DEVICE: GE, 25V, 40MA	80009	152-0075-00
CR5023	152-0141-02			SEMICONV DEVICE: SILICON, 30V, 150MA	80009	152-0141-02
CR5024	152-0141-02			SEMICONV DEVICE: SILICON, 30V, 150MA	80009	152-0141-02
CR5025	152-0141-02			SEMICONV DEVICE: SILICON, 30V, 150MA	80009	152-0141-02
CR5027	152-0141-02			SEMICONV DEVICE: SILICON, 30V, 150MA	80009	152-0141-02
CR5029	152-0141-02			SEMICONV DEVICE: SILICON, 30V, 150MA	80009	152-0141-02
CR5031	152-0141-02			SEMICONV DEVICE: SILICON, 30V, 150MA	80009	152-0141-02
CR5032	152-0141-02			SEMICONV DEVICE: SILICON, 30V, 150MA	80009	152-0141-02
CR5043	152-0141-02			SEMICONV DEVICE: SILICON, 30V, 150MA	80009	152-0141-02
CR5044	150-1050-00			LT EMITTING DIO: RED	50579	RL-T1
CR5045	152-0141-02			SEMICONV DEVICE: SILICON, 30V, 150MA	80009	152-0141-02
CR5046	150-1050-00			LT EMITTING DIO: RED	50579	RL-T1
CR5047	152-0141-02			SEMICONV DEVICE: SILICON, 30V, 150MA	80009	152-0141-02
CR5048	152-0141-02			SEMICONV DEVICE: SILICON, 30V, 150MA	80009	152-0141-02

Ckt No.	Tektronix Part No.	Serial/Model No. Eff	Dscont	Name & Description	Mfr Code	Mfr Part Number
CR5087	152-0141-02			SEMICON DEVICE:SILICON,30V,150MA	80009	152-0141-02
CR5088	152-0141-02			SEMICON DEVICE:SILICON,30V,150MA	80009	152-0141-02
CR5089	152-0141-02			SEMICON DEVICE:SILICON,30V,150MA	80009	152-0141-02
CR5114	152-0622-00			SEMICON DEVICE:VVC,SI,15V,155PF	80009	152-0622-00
CR5122	152-0141-02			SEMICON DEVICE:SILICON,30V,150MA	80009	152-0141-02
CR5125	152-0141-02			SEMICON DEVICE:SILICON,30V,150MA	80009	152-0141-02
CR5180	152-0322-00			SEMICON DEVICE:SILICON,15V,HOT CARRIER	28480	5082-2672
CR5182	152-0322-00			SEMICON DEVICE:SILICON,15V,HOT CARRIER	28480	5082-2672
CR5184	152-0322-00			SEMICON DEVICE:SILICON,15V,HOT CARRIER	28480	5082-2672
CR5186	152-0322-00			SEMICON DEVICE:SILICON,15V,HOT CARRIER	28480	5082-2672
CR5190	152-0322-00			SEMICON DEVICE:SILICON,15V,HOT CARRIER	28480	5082-2672
CR5192	152-0322-00			SEMICON DEVICE:SILICON,15V,HOT CARRIER	28480	5082-2672
CR5194	152-0322-00			SEMICON DEVICE:SILICON,15V,HOT CARRIER	28480	5082-2672
CR5196	152-0322-00			SEMICON DEVICE:SILICON,15V,HOT CARRIER	28480	5082-2672
CR5200	152-0141-02			SEMICON DEVICE:SILICON,30V,150MA	80009	152-0141-02
CR5202	152-0141-02			SEMICON DEVICE:SILICON,30V,150MA	80009	152-0141-02
CR5204	152-0141-02			SEMICON DEVICE:SILICON,30V,150MA	80009	152-0141-02
CR5206	152-0141-02			SEMICON DEVICE:SILICON,30V,150MA	80009	152-0141-02
CR5208	152-0141-02			SEMICON DEVICE:SILICON,30V,150MA	80009	152-0141-02
CR5210	152-0141-02			SEMICON DEVICE:SILICON,30V,150MA	80009	152-0141-02
E5110	276-0532-00			SHLD BEAD,ELEK:FERRITE,0.138 OD X 0.047 ID	02114	56-590-65/4A6
E5113	276-0614-00			CORE,EM:TOROID,FERRITE	78488	57-1656
E5130	276-0614-00			CORE,EM:TOROID,FERRITE	78488	57-1656
K5200	148-0107-01			RELAY,ARMATURE:18VDC COIL	80009	148-0107-01
K5202	148-0107-01			RELAY,ARMATURE:18VDC COIL	80009	148-0107-01
K5204	148-0107-01			RELAY,ARMATURE:18VDC COIL	80009	148-0107-01
K5206	148-0107-01			RELAY,ARMATURE:18VDC COIL	80009	148-0107-01
K5208	148-0107-01			RELAY,ARMATURE:18VDC COIL	80009	148-0107-01
K5210	148-0107-01			RELAY,ARMATURE:18VDC COIL	80009	148-0107-01
L5090	108-0598-00			COIL,RF:200UH	80009	108-0598-00
L5096	108-0598-00			COIL,RF:200UH	80009	108-0598-00
L5098	108-0598-00			COIL,RF:200UH	80009	108-0598-00
L5118	108-0598-00			COIL,RF:200UH	80009	108-0598-00
L5124	108-0598-00			COIL,RF:200UH	80009	108-0598-00
L5126	108-0598-00			COIL,RF:200UH	80009	108-0598-00
L5150	108-0825-00			COIL,RF:1.77UF,TOROIDAL	80009	108-0825-00
L5160	108-0825-00			COIL,RF:1.77UF,TOROIDAL	80009	108-0825-00
L5166	108-0825-00			COIL,RF:1.77UF,TOROIDAL	80009	108-0825-00
L5180	108-0598-00			COIL,RF:200UH	80009	108-0598-00
L5192	108-0701-00			COIL,RF:1.3UH	80009	108-0701-00
L5194	108-0826-00			COIL,RF:1.95 UH,TOROIDAL	80009	108-0826-00
L5196	108-0854-00			COIL,RF:602NH	80009	108-0854-00
L5230	108-0598-00			COIL,RF:200UH	80009	108-0598-00
L5232	108-0598-00			COIL,RF:200UH	80009	108-0598-00
L5236	108-0598-00			COIL,RF:200UH	80009	108-0598-00
L5240	108-0598-00			COIL,RF:200UH	80009	108-0598-00
Q5016	151-0188-00			TRANSISTOR:SILICON,PNP	80009	151-0188-00
Q5020	151-0188-00			TRANSISTOR:SILICON,PNP	80009	151-0188-00
Q5022	151-0190-00			TRANSISTOR:SILICON,NPN	80009	151-0190-00
Q5025	151-0208-00			TRANSISTOR:SILICON,PNP	80009	151-0208-00
Q5030	151-0188-00			TRANSISTOR:SILICON,PNP	80009	151-0188-00
Q5072	151-0190-00			TRANSISTOR:SILICON,NPN	80009	151-0190-00
Q5090	151-0190-00			TRANSISTOR:SILICON,NPN	80009	151-0190-00
Q5092	151-0190-00			TRANSISTOR:SILICON,NPN	80009	151-0190-00
Q5094	151-0190-00			TRANSISTOR:SILICON,NPN	80009	151-0190-00

Replaceable Electrical Parts—7L5 Option 25

Ckt No.	Tektronix Part No.	Serial/Model No. Eff Dscont	Name & Description	Mfr Code	Mfr Part Number
Q5096	151-0190-00		TRANSISTOR:SILICON,NPN	80009	151-0190-00
Q5110	151-0190-00		TRANSISTOR:SILICON,NPN	80009	151-0190-00
Q5112	151-0441-00		TRANSISTOR:SILICON,NPN	80009	151-0441-00
Q5120	151-0441-00		TRANSISTOR:SILICON,NPN	80009	151-0441-00
Q5125	151-0438-00		TRANSISTOR:SILICON,PNP,SEL FROM SPS6927	80009	151-0438-00
Q5130	151-0188-00		TRANSISTOR:SILICON,PNP	80009	151-0188-00
Q5170	151-0441-00		TRANSISTOR:SILICON,NPN	80009	151-0441-00
Q5175	151-0450-00		TRANSISTOR:SILICON,PNP,SEL FROM 2N5583	80009	151-0450-00
Q5185	151-0441-00		TRANSISTOR:SILICON,NPN	80009	151-0441-00
Q5190	151-0441-00		TRANSISTOR:SILICON,NPN	80009	151-0441-00
R5000	311-1324-00		RES.,VAR,WW:10K OHM,5%,2W	02111	534-9572 103J
R5005	311-1714-01		RES.,VAR,NONWIR:15K OHM,20%,1W	80009	311-1714-01
R5010	315-0111-00		RES.,FXD,CMPSN:110 OHM,5%,0.25W	01121	CB1115
R5011	315-0302-00		RES.,FXD,CMPSN:3K OHM,5%,0.25W	01121	CB3025
R5012	315-0331-00		RES.,FXD,CMPSN:330 OHM,5%,0.25W	01121	CB3315
R5013	315-0111-00		RES.,FXD,CMPSN:110 OHM,5%,0.25W	01121	CB1115
R5014	315-0105-00		RES.,FXD,CMPSN:1M OHM,5%,0.25W	01121	CB1055
R5016	315-0222-00		RES.,FXD,CMPSN:2.2K OHM,5%,0.25W	01121	CB2225
R5017	315-0393-00		RES.,FXD,CMPSN:39K OHM,5%,0.25W	01121	CB3935
R5018	315-0331-00		RES.,FXD,CMPSN:330 OHM,5%,0.25W	01121	CB3315
R5019	315-0222-00		RES.,FXD,CMPSN:2.2K OHM,5%,0.25W	01121	CB2225
R5020	315-0393-00		RES.,FXD,CMPSN:39K OHM,5%,0.25W	01121	CB3935
R5021	315-0103-00		RES.,FXD,CMPSN:10K OHM,5%,0.25W	01121	CB1035
R5022	315-0513-00		RES.,FXD,CMPSN:51K OHM,5%,0.25W	01121	CB5135
R5023	315-0513-00		RES.,FXD,CMPSN:51K OHM,5%,0.25W	01121	CB5135
R5024	315-0103-00		RES.,FXD,CMPSN:10K OHM,5%,0.25W	01121	CB1035
R5025	315-0106-00		RES.,FXD,CMPSN:10M OHM,5%,0.25W	01121	CB1065
R5026	315-0102-00		RES.,FXD,CMPSN:1K OHM,5%,0.25W	01121	CB1025
R5027	315-0472-00		RES.,FXD,CMPSN:4.7K OHM,5%,0.25W	01121	CB4725
R5028	315-0104-00		RES.,FXD,CMPSN:100K OHM,5%,0.25W	01121	CB1045
R5029	315-0103-00		RES.,FXD,CMPSN:10K OHM,5%,0.25W	01121	CB1035
R5030	307-0474-00		RES.,FXD,FILM:17 RES. NETWORK	80009	307-0474-00
R5031	315-0103-00		RES.,FXD,CMPSN:10K OHM,5%,0.25W	01121	CB1035
R5032	315-0103-00		RES.,FXD,CMPSN:10K OHM,5%,0.25W	01121	CB1035
R5037	321-0370-00		RES.,FXD,FILM:69.8K OHM,1%,0.125W	91637	MFF1816G69801F
R5038	321-0261-00		RES.,FXD,FILM:5.11K OHM,1%,0.125W	91637	MFF1816G51100F
R5040	315-0102-00		RES.,FXD,CMPSN:1K OHM,5%,0.25W	01121	CB1025
R5041	315-0103-00		RES.,FXD,CMPSN:10K OHM,5%,0.25W	01121	CB1035
R5042	315-0103-00		RES.,FXD,CMPSN:10K OHM,5%,0.25W	01121	CB1035
R5043	315-0102-00		RES.,FXD,CMPSN:1K OHM,5%,0.25W	01121	CB1025
R5044	315-0102-00		RES.,FXD,CMPSN:1K OHM,5%,0.25W	01121	CB1025
R5045	315-0102-00		RES.,FXD,CMPSN:1K OHM,5%,0.25W	01121	CB1025
R5046	315-0103-00		RES.,FXD,CMPSN:10K OHM,5%,0.25W	01121	CB1035
R5047	315-0103-00		RES.,FXD,CMPSN:10K OHM,5%,0.25W	01121	CB1035
R5048	315-0103-00		RES.,FXD,CMPSN:10K OHM,5%,0.25W	01121	CB1035
R5049	315-0103-00		RES.,FXD,CMPSN:10K OHM,5%,0.25W	01121	CB1035
R5050	315-0204-00		RES.,FXD,CMPSN:200K OHM,5%,0.25W	01121	CB2045
R5051	315-0104-00		RES.,FXD,CMPSN:100K OHM,5%,0.25W	01121	CB1045
R5052	307-0445-00		RES,NTWK,FXD,FI:4.7K OHM,20%,(9) RES	91637	MSP10A01 472J
R5054	321-0402-00		RES.,FXD,FILM:150K OHM,1%,0.125W	91637	MFF1816G15002F
R5056	321-0402-00		RES.,FXD,FILM:150K OHM,1%,0.125W	91637	MFF1816G15002F
R5058	321-0373-00		RES.,FXD,FILM:75K OHM,1%,0.125W	91637	MFF1816G75001F
R5060	321-0344-00		RES.,FXD,FILM:37.4K OHM,1%,0.125W	91637	MFF1816G37401F
R5062	321-0315-00		RES.,FXD,FILM:18.7K OHM,1%,0.125W	91637	MFF1816G18701F
R5064	315-0513-00		RES.,FXD,CMPSN:51K OHM,5%,0.25W	01121	CB5135
R5065	315-0513-00		RES.,FXD,CMPSN:51K OHM,5%,0.25W	01121	CB5135

Ckt No.	Tektronix Part No.	Serial/Model No. Eff	Dscont	Name & Description	Mfr Code	Mfr Part Number
R5066	315-0104-00			RES., FXD, CMPSN: 100K OHM, 5%, 0.25W	01121	CB1045
R5068	315-0103-00			RES., FXD, CMPSN: 10K OHM, 5%, 0.25W	01121	CB1035
R5070	315-0513-00			RES., FXD, CMPSN: 51K OHM, 5%, 0.25W	01121	CB5135
R5071	315-0512-00			RES., FXD, CMPSN: 5.1K OHM, 5%, 0.25W	01121	CB5125
R5072	315-0510-00			RES., FXD, CMPSN: 51 OHM, 5%, 0.25W	01121	CB5105
R5074	315-0101-00			RES., FXD, CMPSN: 100 OHM, 5%, 0.25W	01121	CB1015
R5075	315-0100-00			RES., FXD, CMPSN: 10 OHM, 5%, 0.25W	01121	CB1005
R5076	315-0512-00			RES., FXD, CMPSN: 5.1K OHM, 5%, 0.25W	01121	CB5125
R5077	315-0512-00			RES., FXD, CMPSN: 5.1K OHM, 5%, 0.25W	01121	CB5125
R5078	315-0512-00			RES., FXD, CMPSN: 5.1K OHM, 5%, 0.25W	01121	CB5125
R5079	315-0512-00			RES., FXD, CMPSN: 5.1K OHM, 5%, 0.25W	01121	CB5125
R5080	315-0472-00			RES., FXD, CMPSN: 4.7K OHM, 5%, 0.25W	01121	CB4725
R5081	315-0472-00			RES., FXD, CMPSN: 4.7K OHM, 5%, 0.25W	01121	CB4725
R5082	315-0472-00			RES., FXD, CMPSN: 4.7K OHM, 5%, 0.25W	01121	CB4725
R5083	315-0472-00			RES., FXD, CMPSN: 4.7K OHM, 5%, 0.25W	01121	CB4725
R5084	315-0101-00			RES., FXD, CMPSN: 100 OHM, 5%, 0.25W	01121	CB1015
R5086	315-0101-00			RES., FXD, CMPSN: 100 OHM, 5%, 0.25W	01121	CB1015
R5087	315-0102-00			RES., FXD, CMPSN: 1K OHM, 5%, 0.25W	01121	CB1025
R5090	315-0392-00			RES., FXD, CMPSN: 3.9K OHM, 5%, 0.25W	01121	CB3925
R5092	315-0392-00			RES., FXD, CMPSN: 3.9K OHM, 5%, 0.25W	01121	CB3925
R5094	315-0392-00			RES., FXD, CMPSN: 3.9K OHM, 5%, 0.25W	01121	CB3925
R5096	315-0392-00			RES., FXD, CMPSN: 3.9K OHM, 5%, 0.25W	01121	CB3925
R5100	315-0623-00			RES., FXD, CMPSN: 62K OHM, 5%, 0.25W	01121	CB6235
R5102	315-0103-00			RES., FXD, CMPSN: 10K OHM, 5%, 0.25W	01121	CB1035
R5104	315-0153-00			RES., FXD, CMPSN: 15K OHM, 5%, 0.25W	01121	CB1535
R5105	311-1268-00			RES., VAR, NONWIR: 10K OHM, 10%, 0.50W	32997	3329P-L58-103
R5106	315-0204-00			RES., FXD, CMPSN: 20K OHM, 5%, 0.25W	01121	CB2045
R5108	315-0204-00			RES., FXD, CMPSN: 20K OHM, 5%, 0.25W	01121	CB2045
R5110	315-0102-00			RES., FXD, CMPSN: 1K OHM, 5%, 0.25W	01121	CB1025
R5112	315-0682-00			RES., FXD, CMPSN: 6.8K OHM, 5%, 0.25W	01121	CB6825
R5114	315-0152-00			RES., FXD, CMPSN: 1.5K OHM, 5%, 0.25W	01121	CB1525
R5116	315-0392-00			RES., FXD, CMPSN: 3.9K OHM, 5%, 0.25W	01121	CB3925
R5118	315-0470-00			RES., FXD, CMPSN: 47 OHM, 5%, 0.25W	01121	CB4705
R5120	315-0470-00			RES., FXD, CMPSN: 47 OHM, 5%, 0.25W	01121	CB4705
R5121	315-0102-00			RES., FXD, CMPSN: 1K OHM, 5%, 0.25W	01121	CB1025
R5122	315-0182-00			RES., FXD, CMPSN: 1.8K OHM, 5%, 0.25W	01121	CB1825
R5125	315-0102-00			RES., FXD, CMPSN: 1K OHM, 5%, 0.25W	01121	CB1025
R5127	315-0102-00			RES., FXD, CMPSN: 1K OHM, 5%, 0.25W	01121	CB1025
R5128	315-0471-00			RES., FXD, CMPSN: 470 OHM, 5%, 0.25W	01121	CB4715
R5129	315-0300-00			RES., FXD, CMPSN: 30 OHM, 5%, 0.25W	01121	CB3005
R5130	321-0391-00			RES., FXD, FILM: 115K OHM, 1%, 0.125K	91637	MFF1816G11502F
R5131	321-0410-00			RES., FXD, FILM: 182K OHM, 1%, 0.125W	91637	MFF1816G18202F
R5132	321-0385-00			RES., FXD, FILM: 100K OHM, 1%, 0.125W	91637	MFF1816G10002F
R5134	321-0422-00			RES., FXD, FILM: 243K OHM, 1%, 0.125W	91637	MFF1816G24302F
R5136	315-0104-00			RES., FXD, CMPSN: 100K OHM, 5%, 0.25W	01121	CB1045
R5137	315-0513-00			RES., FXD, CMPSN: 51K OHM, 5%, 0.25W	01121	CB5135
R5138	321-0356-00			RES., FXD, FILM: 49.9K OHM, 1%, 0.125W	91637	MFF1816G49901F
R5140	311-1268-00			RES., VAR, NONWIR: 10K OHM, 10%, 0.50W	32997	3329P-L58-103
R5142	315-0623-00			RES., FXD, CMPSN: 62K OHM, 5%, 0.25W	01121	CB6235
R5144	315-0363-00			RES., FXD, CMPSN: 36K OHM, 5%, 0.25W	01121	CB3635
R5145	311-1272-00			RES., VAR, NONWIR: 100K OHM, 10%, 0.50W	32997	3329P-L58-104
R5146	315-0513-00			RES., FXD, CMPSN: 51K OHM, 5%, 0.25W	01121	CB5135
R5147	315-0391-00			RES., FXD, CMPSN: 390 OHM, 5%, 0.25W	01121	CB3915
R5170	315-0510-00			RES., FXD, CMPSN: 51 OHM, 5%, 0.25W	01121	CB5105
R5172	315-0101-00			RES., FXD, CMPSN: 100 OHM, 5%, 0.25W	01121	CB1015
R5174	315-0101-00			RES., FXD, CMPSN: 100 OHM, 5%, 0.25W	01121	CB1015

Replaceable Electrical Parts—7L5 Option 25

Ckt No.	Tektronix Part No.	Serial/Model No. Eff	Discont	Name & Description	Mfr Code	Mfr Part Number
R5175	315-0331-00			RES., FXD, CMPSN: 330 OHM, 5%, 0.25W	01121	CB3315
R5176	315-0331-00			RES., FXD, CMPSN: 330 OHM, 5%, 0.25W	01121	CB3315
R5178	315-0430-00			RES., FXD, CMPSN: 43 OHM, 5%, 0.25W	01121	CB4305
R5180	315-0151-00			RES., FXD, CMPSN: 150 OHM, 5%, 0.25W	01121	CB1515
R5184	315-0303-00			RES., FXD, CMPSN: 30K OHM, 5%, 0.25W	01121	CB3035
R5186	315-0153-00			RES., FXD, CMPSN: 15K OHM, 5%, 0.25W	01121	CB1535
R5188	315-0510-00			RES., FXD, CMPSN: 51 OHM, 5%, 0.25W	01121	CB5105
R5190	315-0100-00			RES., FXD, CMPSN: 10 OHM, 5%, 0.25W	01121	CB1005
R5194	315-0102-00			RES., FXD, CMPSN: 1K OHM, 5%, 0.25W	01121	CB1025
R5196	315-0202-00			RES., FXD, CMPSN: 2K OHM, 5%, 0.25W	01121	CB2025
R5198	315-0102-00			RES., FXD, CMPSN: 1K OHM, 5%, 0.25W	01121	CB1025
R5199	315-0681-00			RES., FXD, CMPSN: 680 OHM, 5%, 0.25W	01121	CB6815
R5200	321-0751-06			RES., FXD, FILM: 50 OHM, 0.25%, 0.125W	91637	MFF1816C50R00C
R5202	321-0091-03			RES., FXD, FILM: 86.6 OHM, 0.25%, 0.125W	91637	MFF1816D86R60C
R5204	321-1170-03			RES., FXD, FILM: 583 OHM, 0.25%, 0.125W	91637	MFF1816D583R0C
R5206	321-1647-07			RES., FXD, FILM: 51.4K OHM, 0.1%, 0.125W	91637	MFF1816C51R40B
R5210	321-1665-03			RES., FXD, FILM: 995 OHM, 0.25%, 0.125W	91637	MFF1816D995R0C
R5212	321-1668-03			RES., FXD, FILM: 52.6 OHM, 0.25%, 0.125W	91637	MFF1816D52R60C
R5214	321-1666-03			RES., FXD, FILM: 153.8 OHM, 0.25%, 0.125W	91637	MFF1816D153R8C
R5216	321-1664-03			RES., FXD, FILM: 68.8 OHM, 0.25%, 0.125W	91637	MFF1816D68R80C
R5218	321-1664-03			RES., FXD, FILM: 68.8 OHM, 0.25%, 0.125W	91637	MFF1816D68R80C
R5220	321-1663-03			RES., FXD, FILM: 23.85 OHM, 0.25%, 0.125W	91637	MFF1816D23R85C
R5222	321-0130-03			RES., FXD, FILM: 221 OHM, 0.25%, 0.125W	91637	MFF1816D221R0C
R5224	321-0130-03			RES., FXD, FILM: 221 OHM, 0.25%, 0.125W	91637	MFF1816D221R0C
R5226	321-1670-03			RES., FXD, FILM: 52.84 OHM, 0.25%, 0.125W	91637	MFF1816D52R84C
R5228	321-1667-03			RES., FXD, FILM: 116.1 OHM, 0.25%, 0.125W	91637	MFF1816D116R1C
R5229	321-1667-03			RES., FXD, FILM: 116.1 OHM, 0.25%, 0.125W	91637	MFF1816D116R1C
S5010	260-0984-00			SWITCH, SLIDE, DP3T, 0.5A, 125V	79727	G-128-S-0012
S5044	263-0019-00			SWITCH PB ASSY: MOMENTARY	80009	263-0019-00
S5046	263-0019-00			SWITCH PB ASSY: MOMENTARY	80009	263-0019-00
T5180	120-0445-00			XFMR, TOROID: 8 TURNS, BIFILAR	80009	120-0445-00
T5185	120-1011-00			XFMR, RF: TOROID, 3 WINDINGS, TRIFILAR	80009	120-1011-00
T5190	120-1084-00			TRANSFORMER, RF: TOROID	80009	120-1084-00
T5195	120-1085-00			TRANSFORMER, RF: TOROID	80009	120-1085-00
U5010	156-0366-00			MICROCIRCUIT, DI: DUAL D-TYPE F-F	80009	156-0366-00
U5020	156-0494-00			MICROCIRCUIT, DI: HEX INVERTER/BUFFER	80009	156-0494-00
U5045	156-0785-11			MICROCIRCUIT, DI: PROM U5045 PROGRAMMED	80009	156-0785-11
U5050	156-0349-00			MICROCIRCUIT, DI: QUAD 2-INPUT NOR GATE	80009	156-0349-00
U5060	156-0582-00			MICROCIRCUIT, DI: BINARY UP/DOWN COUNTER	80009	156-0582-00
U5065	156-0785-12			MICROCIRCUIT, DI: PROM U5065 PROGRAMMED	80009	156-0785-12
U5070	155-0118-00	B010100	B059999	MICROCIRCUIT, DI: VERT CONTROL	80009	155-0118-00
U5070	155-0199-00	B060000		MICROCIRCUIT, DI: VERT CONTROL	80009	155-0199-00
U5075	156-0932-00			MICROCIRCUIT, DI: ROM, CUSTOM MASK	80009	156-0932-00
U5100	156-0158-00			MICROCIRCUIT, LI: DUAL OPERATIONAL AMPLIFIER	80009	156-0158-00
U5145	156-0158-00			MICROCIRCUIT, LI: DUAL OPERATIONAL AMPLIFIER	80009	156-0158-00
U5185	156-0074-00			MICROCIRCUIT, LI: VIDEO AMPL, DIFF INP-OUT	80009	156-0074-00
U5195	156-0742-00			MICROCIRCUIT, LI: OPERATIONAL AMPLIFIER	80009	156-0742-00
VR5026	152-0149-00			SEMICONV DEVICE: ZENER, 0.4W, 10V, 5%	80009	152-0149-00
VR5028	152-0195-00			SEMICONV DEVICE: ZENER, 0.4W, 5.1V, 5%	80009	152-0195-00
VR5031	152-0166-00			SEMICONV DEVICE: ZENER, 0.4W, 6.2V, 5%	81483	69-9035
VR5032	152-0166-00			SEMICONV DEVICE: ZENER, 0.4W, 6.2V, 5%	81483	69-9035
VR5084	152-0278-00			SEMICONV DEVICE: ZENER, 0.4W, 3V, 5%	07910	1N4372A
VR5126	152-0127-00			SEMICONV DEVICE: ZENER, 0.4W, 7.5V, 5%	80009	152-0127-00
VR5176	152-0168-00			SEMICONV DEVICE: ZENER, 0.4W, 12V, 5%	04713	1N963B

Ckt No.	Tektronix Part No.	Serial/Model No. Eff	Dscont	Name & Description	Mfr Code	Mfr Part Number
Y5110	158-0117-00			XTAL UNIT,QTZ:10.7 MHZ,0.002%	75378	H3

<http://www.ebaman.com>

DIAGRAM AND CIRCUIT BOARD ILLUSTRATION

Symbols and Reference Designators

Graphic symbols for electrical and logic symbols, used on the diagrams, are based on ANSI Y32.2, 1970, and ANSI Y32.14, 1973, "American National Standards Institute." Logic symbols depict the logic function of the device in positive logic. Copies of these standards can be obtained from the Institute of Electrical and Electronics Engineers, 345 East 47th Street, New York, N.Y., 11017. Exceptions and additions are shown on this sample diagram. These conform or are based on the manufacturers data sheet and industry trends.

Resistor values are in ohms, unless noted otherwise, and the Ω symbol is omitted. Capacitor values ≥1 (e.g. 10) are in picofarads (pF) and values <1 (e.g. 0.01) are in microfarads unless otherwise noted.

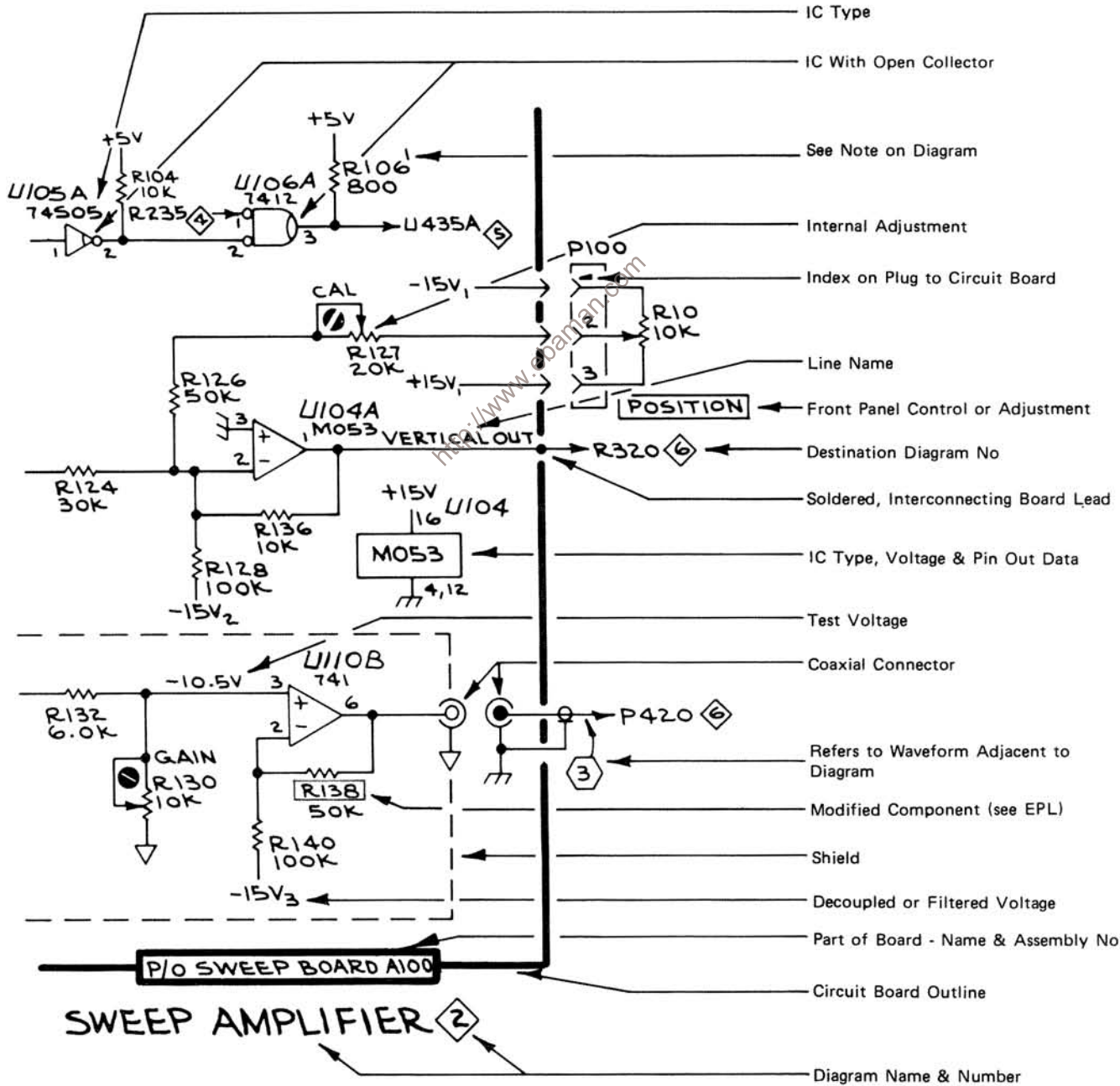

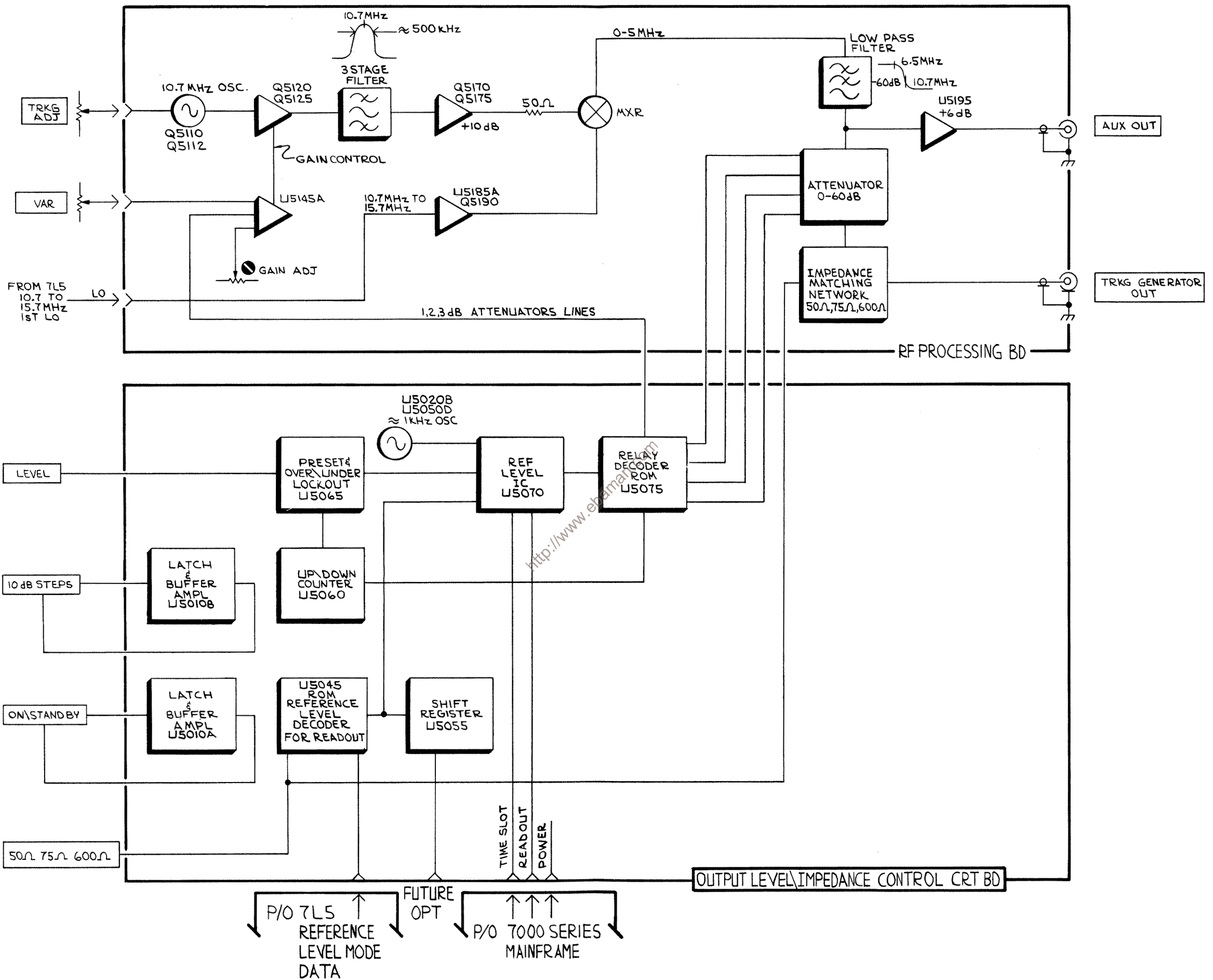

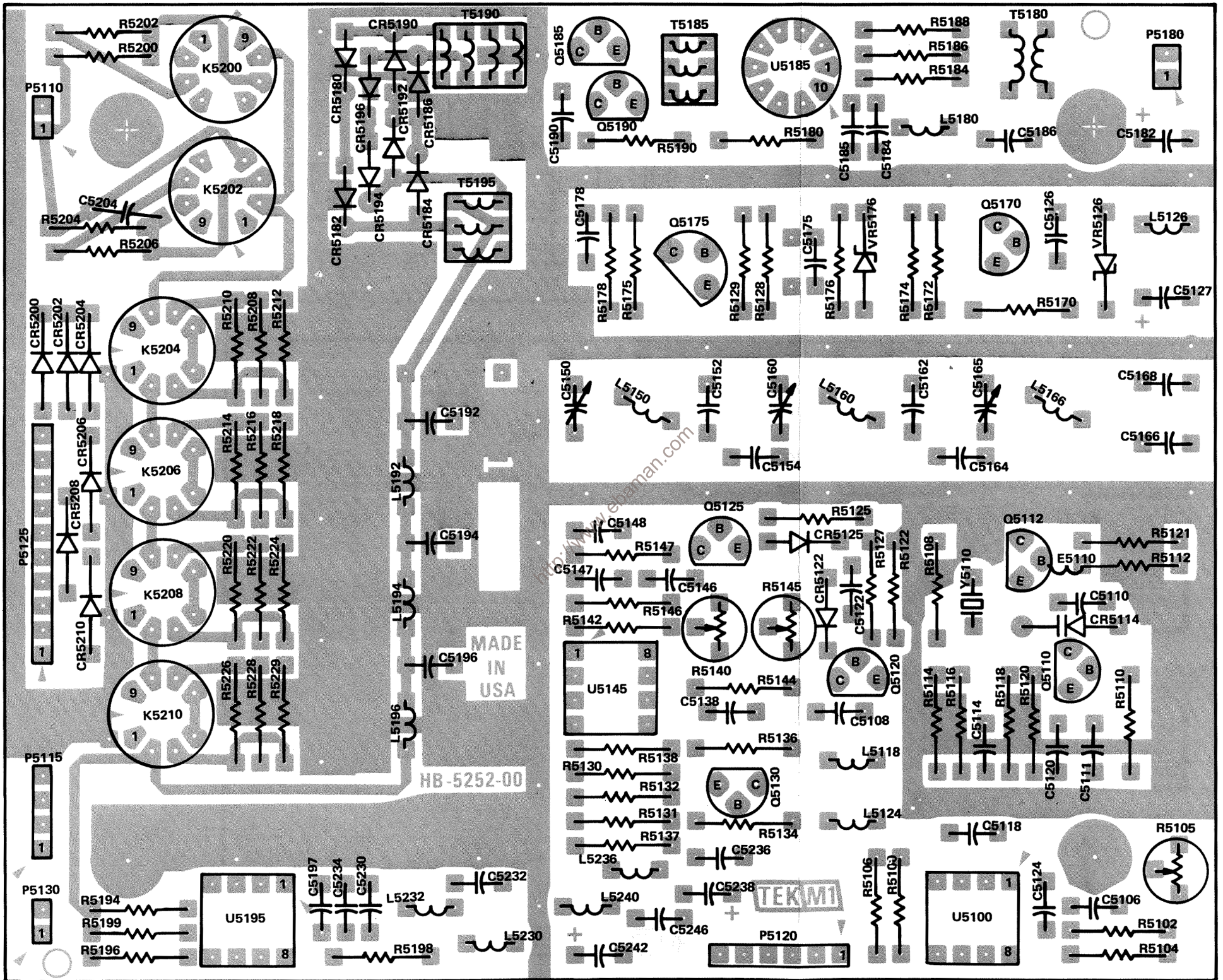

A5100 RF Processing Board

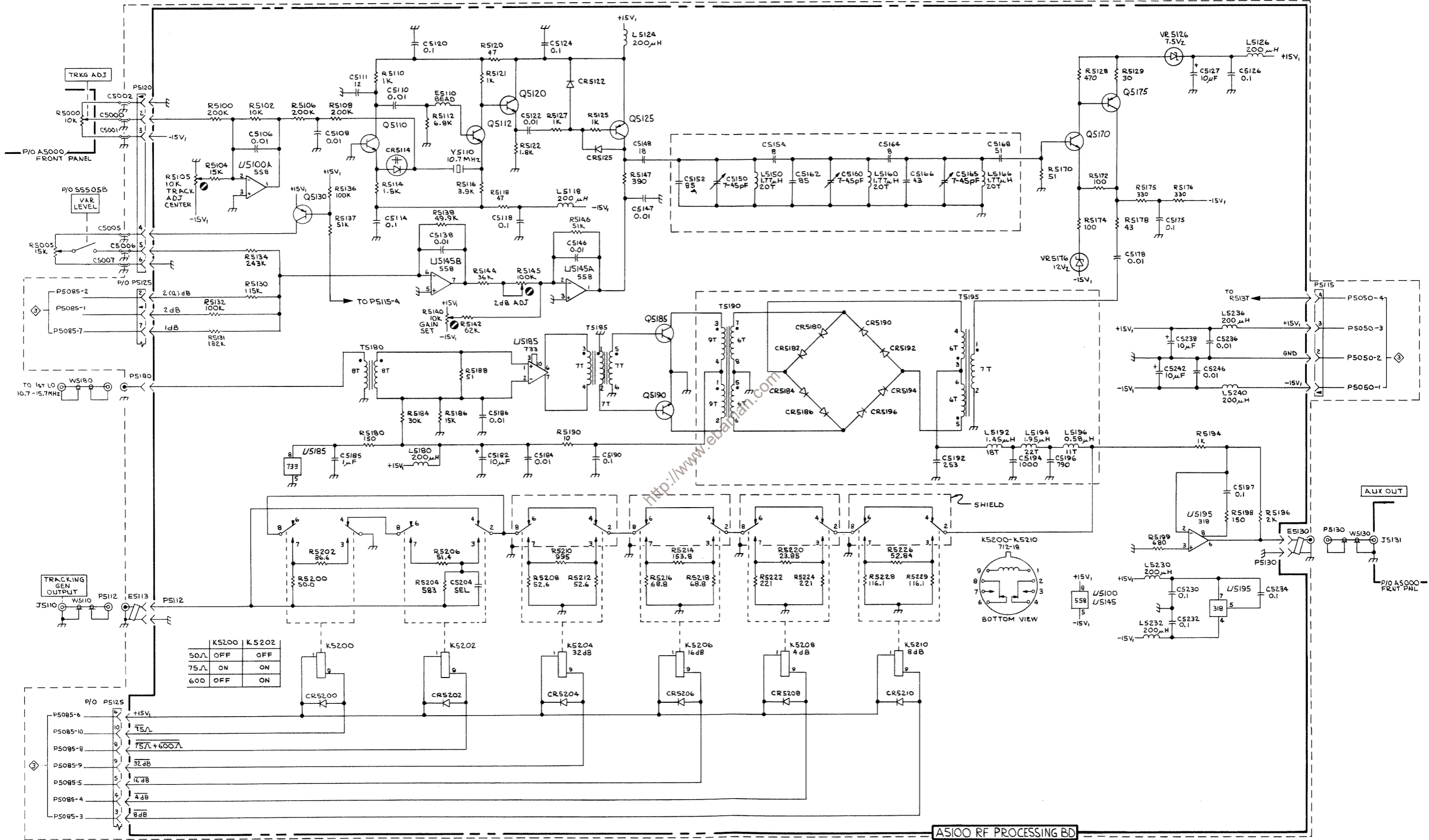

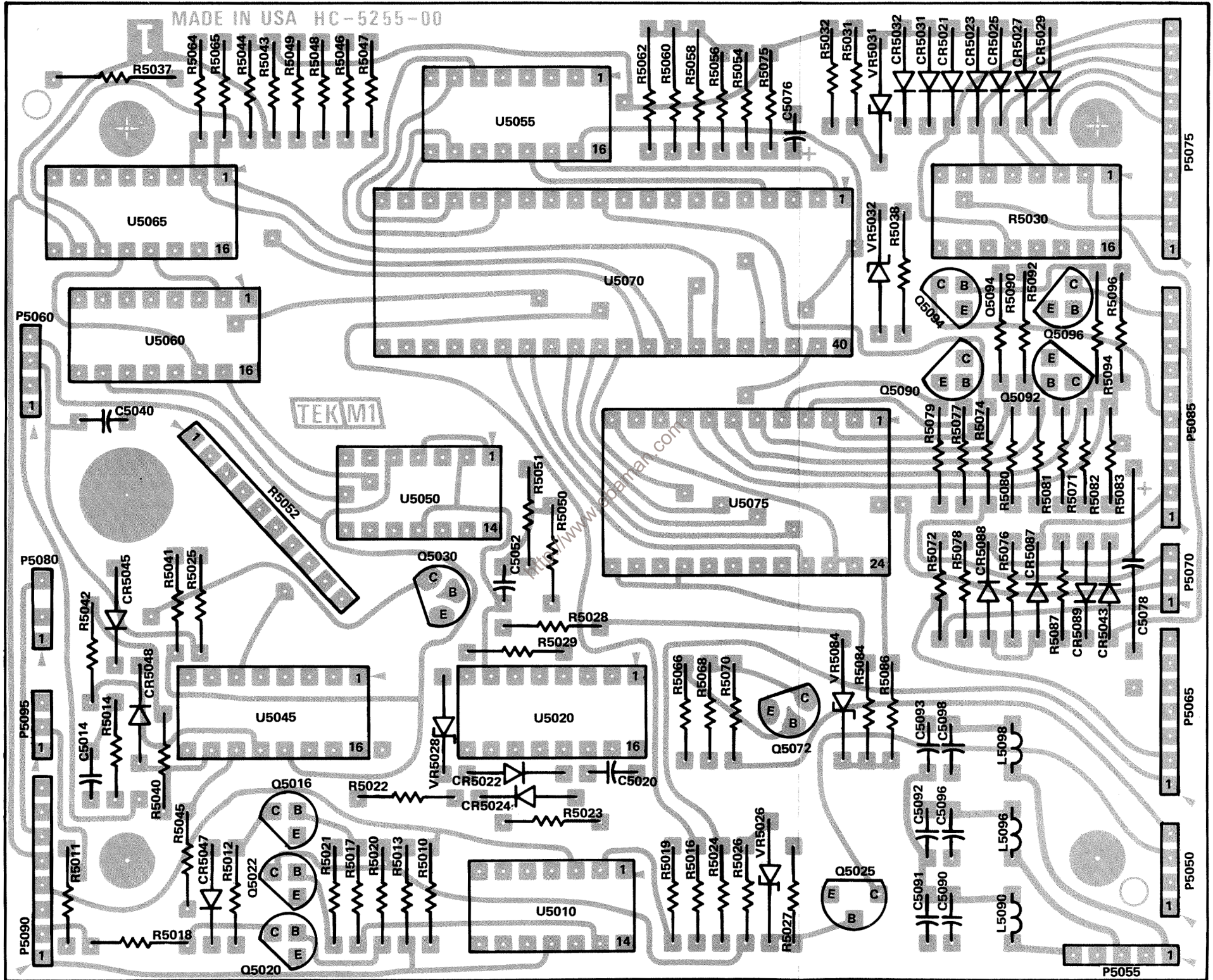

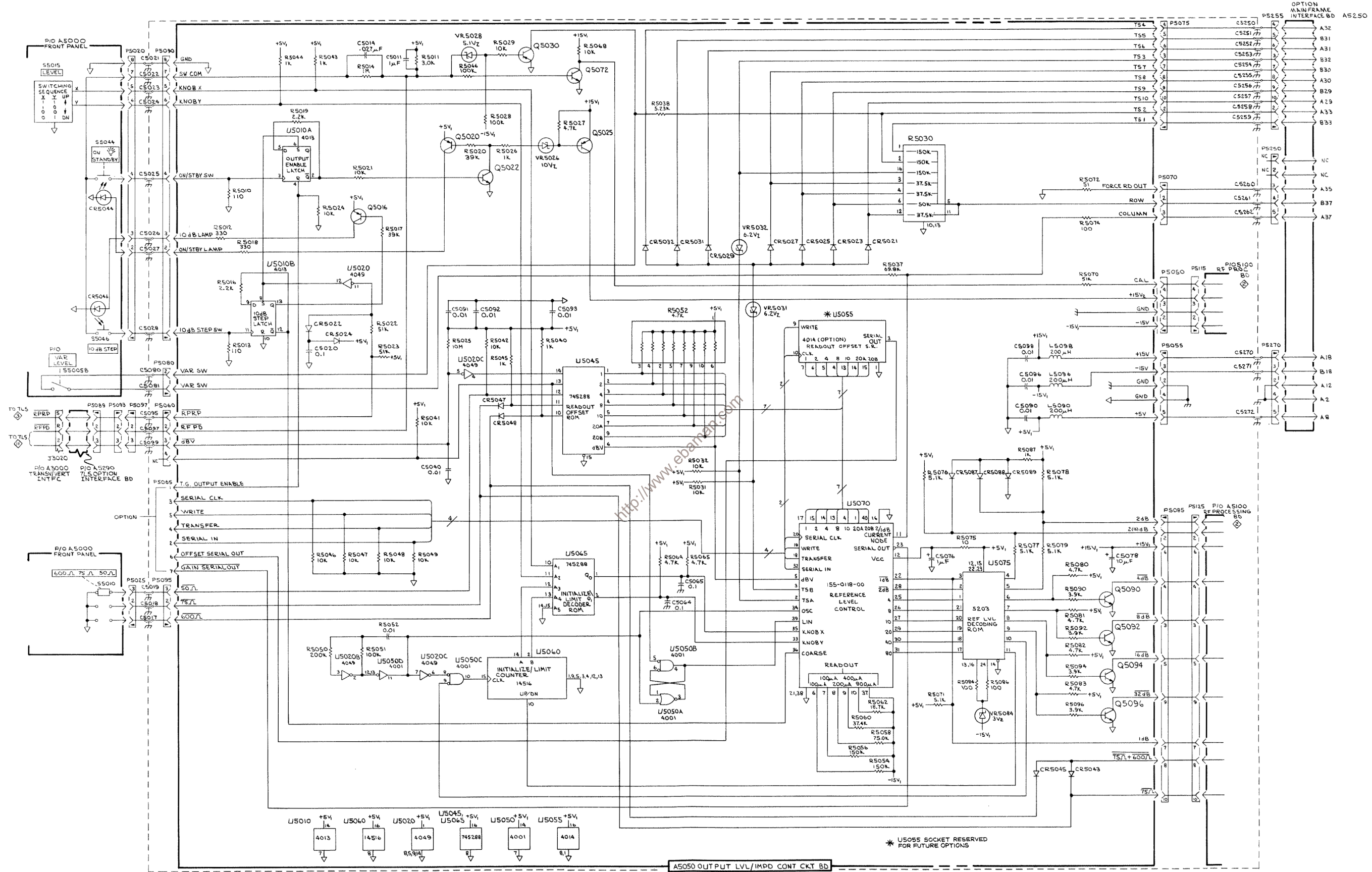

AS250 OUTPUT LVL/IMPED CONT CKT BD

* U5055 SOCKET RESERVED FOR FUTURE OPTIONS

REPLACEABLE MECHANICAL PARTS

PARTS ORDERING INFORMATION

Replacement parts are available from or through your local Tektronix, Inc. Field Office or representative.

Changes to Tektronix instruments are sometimes made to accommodate improved components as they become available, and to give you the benefit of the latest circuit improvements developed in our engineering department. It is therefore important, when ordering parts, to include the following information in your order: Part number, instrument type or number, serial number, and modification number if applicable.

If a part you have ordered has been replaced with a new or improved part, your local Tektronix, Inc. Field Office or representative will contact you concerning any change in part number.

Change information, if any, is located at the rear of this manual.

SPECIAL NOTES AND SYMBOLS

- X000 Part first added at this serial number
- 00X Part removed after this serial number

FIGURE AND INDEX NUMBERS

Items in this section are referenced by figure and index numbers to the illustrations.

INDENTATION SYSTEM

This mechanical parts list is indented to indicate item relationships. Following is an example of the indentation system used in the description column.

```

1 2 3 4 5           Name & Description
Assembly and/or Component
Attaching parts for Assembly and/or Component
    - - - * - - -
Detail Part of Assembly and/or Component
Attaching parts for Detail Part
    - - - * - - -
Parts of Detail Part
Attaching parts for Parts of Detail Part
    - - - * - - -
    
```

Attaching Parts always appear in the same indentation as the item it mounts, while the detail parts are indented to the right. Indented items are part of, and included with, the next higher indentation. The separation symbol - - - * - - - indicates the end of attaching parts.

Attaching parts must be purchased separately, unless otherwise specified.

ITEM NAME

In the Parts List, an Item Name is separated from the description by a colon (:). Because of space limitations, an Item Name may sometimes appear as incomplete. For further Item Name identification, the U.S. Federal Cataloging Handbook H6-1 can be utilized where possible.

ABBREVIATIONS

"	INCH	ELECTRN	ELECTRON	IN	INCH	SE	SINGLE END
#	NUMBER SIZE	ELEC	ELECTRICAL	INCAND	INCANDESCENT	SECT	SECTION
ACTR	ACTUATOR	ELECTLT	ELECTROLYTIC	INSUL	INSULATOR	SEMICOND	SEMICONDUCTOR
ADPTR	ADAPTER	ELEM	ELEMENT	INTL	INTERNAL	SHLD	SHIELD
ALIGN	ALIGNMENT	EPL	ELECTRICAL PARTS LIST	LPHLDR	LAMPHOLDER	SHLDR	SHOULDERED
AL	ALUMINUM	EQPT	EQUIPMENT	MACH	MACHINE	SKT	SOCKET
ASSEM	ASSEMBLED	EXT	EXTERNAL	MECH	MECHANICAL	SL	SLIDE
ASSY	ASSEMBLY	FIL	FILLISTER HEAD	MTG	MOUNTING	SLFLKG	SELF-LOCKING
ATTEN	ATTENUATOR	FLEX	FLEXIBLE	NIP	NIPPLE	SLVG	SLEEVING
AWG	AMERICAN WIRE GAGE	FLH	FLAT HEAD	NON WIRE	NOT WIRE WOUND	SPR	SPRING
BD	BOARD	FLTR	FILTER	OBD	ORDER BY DESCRIPTION	SQ	SQUARE
BRKT	BRACKET	FR	FRAME or FRONT	OD	OUTSIDE DIAMETER	SST	STAINLESS STEEL
BRS	BRASS	FSTNR	FASTENER	OVH	OVAL HEAD	STL	STEEL
BRZ	BRONZE	FT	FOOT	PH BRZ	PHOSPHOR BRONZE	SW	SWITCH
BSHG	BUSHING	FXD	FIXED	PL	PLAIN or PLATE	T	TUBE
CAB	CABINET	GSKT	GASKET	PLSTC	PLASTIC	TERM	TERMINAL
CAP	CAPACITOR	HDL	HANDLE	PN	PART NUMBER	THD	THREAD
CER	CERAMIC	HEX	HEXAGON	PNH	PAN HEAD	THK	THICK
CHAS	CHASSIS	HEX HD	HEXAGONAL HEAD	PWR	POWER	TNSN	TENSION
CKT	CIRCUIT	HEX SOC	HEXAGONAL SOCKET	RCPT	RECEPTACLE	TPG	TAPPING
COMP	COMPOSITION	HLCPS	HELICAL COMPRESSION	RES	RESISTOR	TRH	TRUSS HEAD
CONN	CONNECTOR	HLEXT	HELICAL EXTENSION	RGD	RIGID	V	VOLTAGE
COV	COVER	HV	HIGH VOLTAGE	RLF	RELIEF	VAR	VARIABLE
CPLG	COUPLING	IC	INTEGRATED CIRCUIT	RTNR	RETAINER	W/	WITH
CRT	CATHODE RAY TUBE	ID	INSIDE DIAMETER	SCH	SOCKET HEAD	WSHR	WASHER
DEG	DEGREE	IDENT	IDENTIFICATION	SCOPE	OSCILLOSCOPE	XFMR	TRANSFORMER
DWR	DRAWER	IMPLR	IMPELLER	SCR	SCREW	XSTR	TRANSISTOR

CROSS INDEX—MFR. CODE NUMBER TO MANUFACTURER

Mfr. Code	Manufacturer	Address	City, State, Zip
000CY	NORTHWEST FASTENER SALES, INC.	7923 SW CIRRUS DRIVE	BEAVERTON, OREGON 97005
00779	AMP, INC.	P O BOX 3608	HARRISBURG, PA 17105
01295	TEXAS INSTRUMENTS, INC., SEMICONDUCTOR GROUP	P O BOX 5012, 13500 N CENTRAL EXPRESSWAY	DALLAS, TX 75222
08261	SPECTRA-STRIP CORP.	7100 LAMPSON AVE.	GARDEN GROVE, CA 92642
13257	AMERACE, LTD.	10 ESNA PARK DRIVE	MARKHAM, ONTARIO, CANADA
22526	BERG ELECTRONICS, INC.	YOUK EXPRESSWAY	NEW CUMBERLAND, PA 17070
73743	FISCHER SPECIAL MFG. CO.	446 MORGAN ST.	CINCINNATI, OH 45206
73803	TEXAS INSTRUMENTS, INC., METALLURGICAL MATERIALS DIV.	34 FOREST STREET	ATTLEBORO, MA 02703
74445	HOLO-KROME CO.	31 BROOK ST. WEST	HARTFORD, CT 06110
80009	TEKTRONIX, INC.	P O BOX 500	BEAVERTON, OR 97077
82647	TEXAS INSTRUMENTS, INC., CONTROL PRODUCTS DIV.	34 FOREST ST.	ATTLEBORO, MA 02703
83385	CENTRAL SCREW CO.	2530 CRESCENT DR.	BROADVIEW, IL 60153
86445	PENN FIBRE AND SPECIALTY CO., INC.	2032 E. WESTMORELAND ST.	PHILADELPHIA, PA 19134
87308	N. L. INDUSTRIES, INC., SOUTHERN SCREW DIV.	P. O. BOX 1360	STATESVILLE, NC 28677
91836	KINGS ELECTRONICS CO., INC.	40 MARBLEDALE ROAD	TUCKAHOE, NY 10707
98291	SEAELECTRO CORP.	225 HOYT	MAMARONECK, NY 10544

<http://www.ebaman.com>

Fig. & Index No.	Tektronix Part No.	Serial/Model No. Eff	Dscont	Qty	1	2	3	4	5	Name & Description	Mfr Code	Mfr Part Number
1-1	337-1064-09			1						SHIELD,ELEC:LEFT SIDE	80009	337-1064-09
-2	366-1183-00			1						KNOB:GRAY	80009	366-1183-00
	213-0725-00			1						. SETSCREW:3-48 X 0.095 INCH,HEX SOC STL	74445	OBD
-3	366-1164-00			1						KNOB:GRAY	80009	366-1164-00
	213-0153-00			2						. SETSCREW:5-40 X 0.125,STL BK OXD,HEX	000CY	OBD
-4	366-1389-00			1						KNOB:GRAY	80009	366-1389-00
	213-0306-00			1						. SETSCREW:2-56 X 0.062 INCH,OX STL	74445	OBD
-5	200-0698-00			1						COV,COMPEN BOX:	80009	200-0698-00
-6	346-0045-00			1						STRAP,CONN COV:BNC ONE END,POLYPROPYLENE	80009	346-0045-00
-7	333-2237-00			1						PANEL,FRONT:	80009	333-2237-00
-8	348-0235-00			2						SHLD GSKT,ELEC:4.734 INCH LONG	80009	348-0235-00
-9	195-0180-00			1						LEAD,ELECTRICAL:50 OHM COAX,11.25 LONG	80009	195-0180-00
-10	195-0180-00			1						LEAD,ELECTRICAL:50 OHM COAX,11.25 LONG	80009	195-0180-00
-11	131-0818-00			2						CONNECTOR,RCPT,:BNC,FEMALE	91836	KC19-153BNC
-12	-----			1						CKT BOARD ASSY:FRONT PANEL(SEE A5000 EPL) (ATTACHING PARTS)		
-13	211-0116-00			4						SCR,ASSEM WSHR:4-40 X 0.312 INCH,PNH BRS - - - * - - -	83385	OBD
	-----			-						. CKT BOARD ASSY INCLUDES:		
-14	-----			1						. SWITCH,SLIDE:(SEE S5010 EPL)		
-15	388-5253-00			2						. CIRCUIT BOARD:SWITCH MODULE	80009	388-5253-00
-16	361-0814-00			4						. SPACER,CKT CARD:	80009	361-0814-00
-17	214-1579-00			1						. SPRING,DETENT:0.59 ID X 0.08 W X 0.01 THK	80009	214-1579-00
-18	214-1127-00			1						. ROLLER,DETENT:0.125 DIA X 0.125 INCH L	80009	214-1127-00
-19	380-0244-00			1						. HOUSING,SWITCH:POLYCARBONATE (ATTACHING PARTS)	80009	380-0244-00
-20	210-0405-00			3						. NUT,PLAIN,HEX.:2-56 X 0.188 INCH,BRS - - - * - - -	73743	2X12157-402
-21	384-0994-04			1						. SHAFT,ROTARY SW:Ø16 POSN DETENT AND CONT	80009	384-0994-04
	210-1184-00	XB071200		2						. WASHER,FLAT:0.195 ID X 0.375" OD,TEFLON	86445	OBD
-22	-----			2						. ACTR ASSY,PR:(SEE S5044,S5046 EPL)		
-23	131-0608-00			11						. TERMINAL,PN:0.365 L X 0.25 PH,BRZ,GOLD PL	22526	47357
-24	-----			1						. RESISTOR,VAR:(SE R5005 EPL) (ATTACHING PARTS)		
-25	211-0022-00			2						. SCREW,MACHINE:2-56 X 0.188 INCH,PNH STL - - - * - - -	83385	OBD
-26	386-2029-00			1						. PL,VAR RES MTG:ALUMINUM	80009	386-2029-00
-27	200-1232-00			1						. COVER,RTRY SW:CIRCUIT BOARD	80009	200-1232-00
-28	401-0127-02			1						. ROTOR-CONT ASSY:DELRIN,W/O CONTACTS	80009	401-0127-02
-29	129-0301-00			2						. POST,ELEC-MECH:0.156 HEX X 0.312 L,BRS (ATTACHING PARTS FOR EACH)	80009	129-0301-00
-30	211-0022-00			1						. SCREW,MACHINE:2-56 X 0.188 INCH,PNH STL - - - * - - -	83385	OBD
-31	-----			1						. RESISTOR,VAR:(SEE R5000 EPL) (ATTACHING PARTS)		
-32	210-0583-00			2						. NUT,PLAIN,HEX.:0.25-32 X 0.312 INCH,BRS - - - * - - -	73743	2X20224-402
-33	386-1447-84			1						SUBPANEL,FRONT: (ATTACHING PARTS)	80009	386-1447-84
-34	213-0192-00			4						SCR,TPG,THD FOR:6-32 X 0.50 INCH,PNH STL - - - * - - -	87308	OBD
-35	211-0001-00			2						SCREW,MACHINE:2-56 X 0.25 INCH,PNH STL	83385	OBD
-36	407-1878-00			1						BRACKET,ANGLE:ALUMINUM (ATTACHING PARTS)	80009	407-1878-00
-37	211-0529-00			1						SCREW,MACHINE:6-32 X 1.25 INCHES,PNH STL - - - * - - -	83385	OBD
-38	200-2060-00			1						COVER,TOP: (ATTACHING PARTS)	80009	200-2060-00
-39	211-0007-00			10						SCREW,MACHINE:4-40 X 0.188 INCH,PNH STL - - - * - - -	83385	OBD
-40	-----			1						CKT BOARD ASSY:OUT LVL/IMPD(SEE A5050 EPL) (ATTACHING PARTS)		
-41	211-0008-00			4						SCREW,MACHINE:4-40 X 0.25 INCH,PNH STL - - - * - - -	83385	OBD

Replaceable Mechanical Parts—7L5 Option 25

Fig. & Index No.	Tektronix Part No.	Serial/Model No. Eff	Dscont	Qty	1	2	3	4	5	Name & Description	Mfr Code	Mfr Part Number
1-	-----			-						. CKT BOARD ASSY INCLUDES:		
-42	136-0578-00			1						. SOCKET, PLUG-IN: 24 DIP, LOW PROFILE	01295	C952402
-43	136-0252-04			30						. SOCKET, PIN TERM: 0.188 INCH LONG	22526	75060
-44	136-0260-02			6						. SOCKET, PLUG-IN: 16 CONTACT, LOW CLEARANCE	82647	C9316-18
-45	131-0608-00			56						. TERMINAL, PIN: 0.365 L X 0.25 PH, BRZ, GOLD PL	22526	47357
-46	136-0269-02			2						. SOCKET, PLUG-IN: 14 CONTACT, LOW CLEARANCE	01295	C95140
-47	346-0130-00	B010100	B059999X	1						. STRAP, RETAINING: FOR 40 CONTACT SBSTR SKT	00779	350894-1
-48	136-0641-00	B010100	B059999	1						. SOCKET, PLUG-IN: 40 CONTACT	00779	1-485169-2
	136-0623-00	B060000	B071199	1						. SOCKET, PLUG-IN: 40 DIP, LOW PROFILE	73803	C954002
	136-0252-04	B071200		40						. SOCKET, PIN TERM: 0.188 INCH LONG	22526	75060
-49	-----			1						CKT BOARD ASSY: RF PROCESSING (SEE A5100 EPL) (ATTACHING PARTS)		
-50	211-0008-00			4						SCREW, MACHINE: 4-40 X 0.25 INCH, PNH STL - - - * - - -	83385	OBD
	-----			-						. CKT BOARD ASSY INCLUDES:		
-51	131-0608-00			23						. TERMINAL, PIN: 0.365 L X 0.25 PH, BRZ, GOLD PL	22526	47357
-52	136-0252-04			28						. SOCKET, PIN TERM: 0.188 INCH LONG	22526	75060
-53	136-0514-00			3						. SOCKET, PLUG IN: MICROCIRCUIT, 8 CONTACT	82647	C93-08-18
-54	337-2390-00			1						. SHIELD, ELEC: CIRCUIT CARD	80009	337-2390-00
-55	337-2389-00			1						. SHIELD, ELEC: CIRCUIT CARD	80009	337-2389-00
-56	337-2391-00			1						. SHIELD, ELEC: CIRCUIT CARD	80009	337-2391-00
-57	381-0389-00			1						BAR, CAP. MTG: BRS CU-SN-ZN PL (ATTACHING PARTS)	80009	381-0389-00
-58	211-0008-00			2						SCREW, MACHINE: 4-40 X 0.25 INCH, PNH STL	83385	OBD
-59	210-0406-00			1						NUT, PLAIN, HEX.: 4-40 X 0.188 INCH, BRS	73743	2X12161-402
-60	210-0261-00			2						TERMINAL, LUG: 0.14 ID, PLAIN, BRASS	80009	210-0261-00
-61	211-0012-00			1						SCREW, MACHINE: 4-40 X 0.375 INCH, PNH STL - - - * - - -	83385	OBD
-62	131-0372-00			3						CONNECTOR, RCPT, : COAXIAL	98291	51-043-4300
-63	-----			3						CAP., FXD, CER DI: (SEE C5270, C5271, C5272 EPL)		
-64	195-0179-00			1						LEAD, ELECTRICAL: 50 OHM COAX, 9.25 INCH LONG	80009	195-0179-00
-65	441-1352-00			1						CHAS, PL-IN UNIT: CIRCUIT CARDS (ATTACHING PARTS)	80009	441-1352-00
-66	211-0025-00			6						SCREW, MACHINE: 4-40 X 0.375 100 DEG, FLH STL - - - * - - -	83385	OBD
-67	-----			1						CKT BOARD ASSY: MNFRM INTFC (SEE A5250 EPL)		
-68	131-0827-00			10						. CONTACT, ELEC: 0.55 INCH LONG	22526	47349
-69	131-0608-00			45						. TERMINAL, PIN: 0.365 L X 0.25 PH, BRZ, GOLD PL	22526	47357
-70	351-0217-01			1						GUIDE, CKT CARD: PLASTIC (ATTACHING PARTS)	80009	351-0217-01
-71	220-0557-00			4						NUT, SLEEVE: 6-32 X 0.204 OD X 0.118 L BRS	80009	220-0557-00
-72	211-0507-00			4						SCREW, MACHINE: 6-32 X 0.312 INCH, PNH STL - - - * - - -	83385	OBD
-73	386-3636-00			1						PANEL, REAR: (ATTACHING PARTS)	80009	386-3636-00
-74	213-0192-00			2						SCR, TPG, THD FOR: 6-32 X 0.50 INCH, PNH STL	87308	OBD
-75	210-0589-00			2						NUT, SELF LKG HE: 4-40 X 0.250 INCH	13257	22 NM-40
-76	210-1160-00			2						WASHER, NONMETAL: 0.109 ID X 0.25 INCH OD	86445	OBD
-77	211-0012-00			2						SCREW, MACHINE: 4-40 X 0.375 INCH, PNH STL - - - * - - -	83385	OBD
-78	426-1343-00			1						FR SECT, PLUG-IN: TOP	80009	426-1343-00
-79	426-1344-00			1						FR SECT, PLUG-IN: BOTTOM	80009	426-1344-00
	129-0404-00	XB071200		1						SPACER, POST: 0.853 L X 0.188 HEX, BRASS	80009	129-0404-00
-80	-----			1						CKT BOARD ASSY: OPTION INTFC (SEE A5290 EPL)		
-81	131-1425-00			1						. CONTACT SET, ELE: R ANGLE, 0.150" L, STR OF 36	22526	65521-136
	198-3316-00			1						WIRE SET, ELEC:	80009	198-3316-00
-82	131-0965-00			3						. CONTACT, ELEC: 0.25" SQ, 22-26 AWG WIRE	22526	47792
-83	131-0707-00			109						. CONNECTOR, TERM.: 22-26 AWG, BRS & CU BE GOLD	22526	47439
-84	352-0171-02			1						. CONN BODY, PL, EL: 1 WIRE RED	80009	352-0171-02
	352-0171-03			1						. CONN BODY, PL, EL: 1 WIRE ORANGE	80009	352-0171-03
	352-0171-04			1						. CONN BODY, PL, EL: 1 WIRE YELLOW	80009	352-0171-04
-85	352-0169-03			1						. CONN BODY, PL, EL: 2 WIRE ORANGE	80009	352-0169-03
-86	352-0161-01			1						. CONN BODY, PL, EL: 3 WIRE BROWN	80009	352-0161-01
	352-0161-02			1						. CONN BODY, PL, EL: 3 WIRE RED	80009	352-0161-02
	352-0161-06			1						. CONN BODY, PL, EL: 3 WIRE BLUE	80009	352-0161-06

Replaceable Mechanical Parts—7L5 Option 25

Fig. & Index No.	Tektronix Part No.	Serial/Model No.		Qty	1 2 3 4 5	Name & Description	Mfr Code	Mfr Part Number
		Eff	Dscont					
1-	352-0161-09			1	.	CONN BODY, PL, EL: 3 WIRE WHITE	80009	352-0161-09
-87	352-0162-00			2	.	HLDR, TERM CONN: 4 WIRE BLACK	80009	352-0162-00
	352-0162-02			2	.	CONN BODY, PL, EL: 4 WIRE RED	80009	352-0162-02
	352-0162-04			1	.	CONN BODY, PL, EL: 4 WIRE YELLOW	80009	352-0162-04
-88	352-0163-01			1	.	CONN BODY, PL, EL: 5 WIRE BROWN	80009	352-0163-01
	352-0163-09			2	.	CONN BODY, PL, EL: 5 WIRE WHITE	80009	352-0163-09
-89	352-0164-01			1	.	CONN BODY, PL, EL: 6 WIRE BROWN	80009	352-0164-01
-90	352-0166-01			1	.	CONN BODY, PL, EL: 8 WIRE BROWN	80009	352-0166-01
	352-0166-02			1	.	CONN BODY, PL, EL: 8 WIRE RED	80009	352-0166-02
-91	352-0168-00			1	.	CONN BODY, PL, EL: 10 WIRE BLACK	80009	352-0168-00
	352-0168-02			1	.	CONN BODY, PL, EL: 10 WIRE RED	80009	352-0168-02
	352-0168-04			1	.	CONN BODY, PL, EL: 10 WIRE YELLOW	80009	352-0168-04
	352-0168-06			1	.	CONN BODY, PL, EL: 10 WIRE BLUE	80009	352-0168-06
-92	175-0825-00			FT	.	WIRE, ELECTRICAL: 2 WIRE RIBBON	80009	175-0825-00
-93	175-0826-00			FT	.	WIRE, ELECTRICAL: 3 WIRE RIBBON	80009	175-0826-00
-94	175-0827-00			FT	.	WIRE, ELECTRICAL: 4 WIRE RIBBON	08261	SS-0426-710610C
-95	175-0828-00			FT	.	WIRE, ELECTRICAL: 5 WIRE RIBBON	08261	OBD
-96	175-0829-00			FT	.	WIRE, ELECTRICAL: 6 WIRE RIBBON	08261	SS-0626-710610C
-97	175-0831-00			FT	.	WIRE, ELECTRICAL: 8 WIRE RIBBON	08261	OBD
-98	175-0833-00			FT	.	WIRE, ELECTRICAL: 10 WIRE RIBBON	08261	OBD

<http://www.ebaman.com>

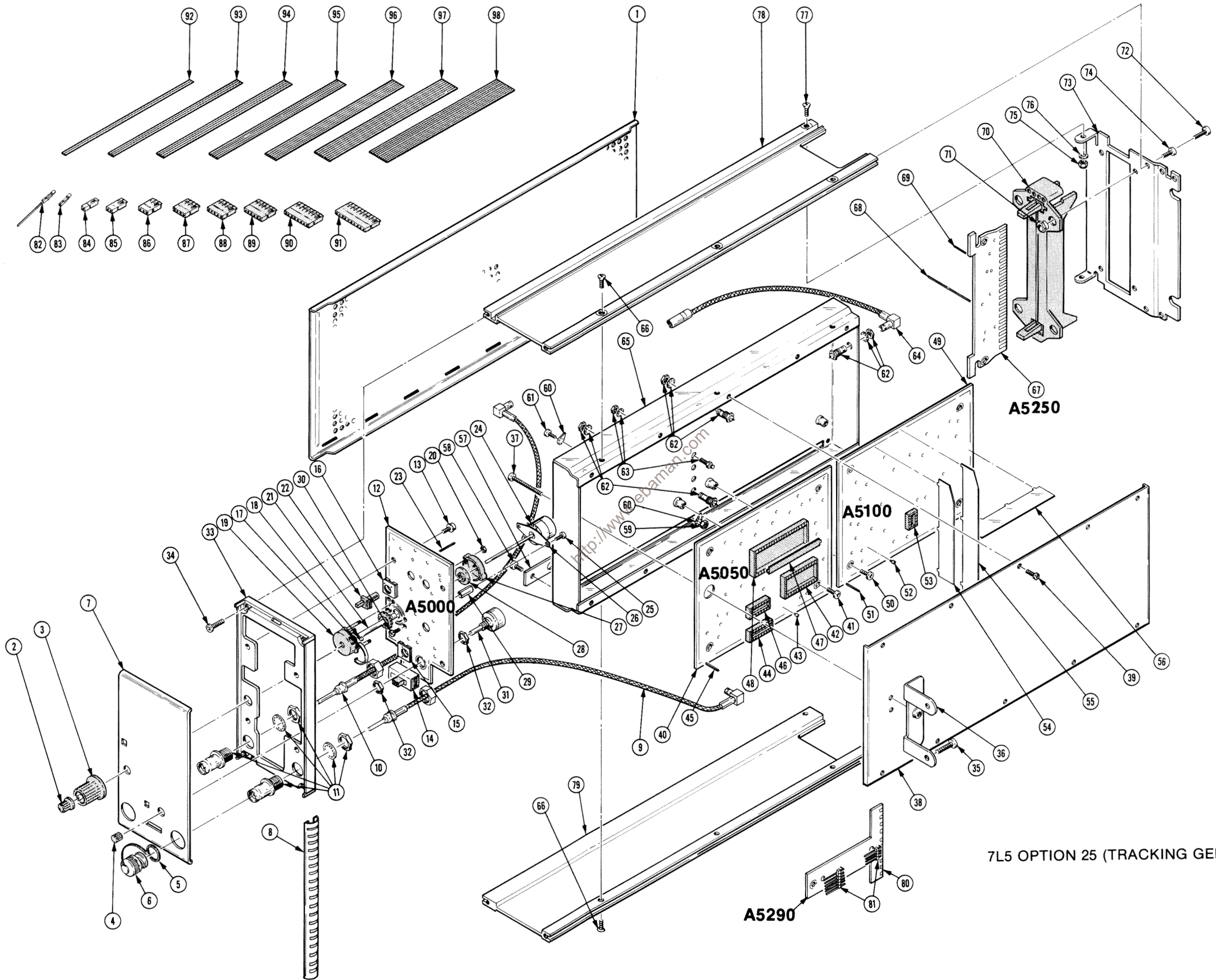

7L5 OPTION 25 (TRACKING GENERATOR)

Fig. & Index No.	Tektronix Part No.	Serial/Model No. Eff	No. Dscont	Qty						Name & Description	Mfr	
					1	2	3	4	5		Code	Mfr Part Number
	070-2155-03			1						MANUAL, TECH:INSTRUCTION	80009	070-2155-03

<http://www.ebaman.com>

7L5 OPTION 28

Readout

General Information

The 7L5 Option 28 provides reference level and dot frequency readout when it is installed and used in a 7000-Series mainframe that does not have crt readout. If the instrument is installed in a mainframe with readout, it will not affect the normal operation of the readout and will blank itself.

<http://www.ebaman.com>

TABLE OF CONTENTS

		Page
SECTION 1	SPECIFICATIONS	1-1
	Standard Accessories	1-1
	Operation	1-1

WARNING

The remaining portion of this table of contents lists service instructions for use by qualified service personnel only. To avoid electrical shock or other personal injury, do not perform any servicing other than that described in operation instructions unless you are qualified to do so.

SECTION 2	SERVICE INSTRUCTIONS	2-1
	Maintenance	2-1
	Calibration	2-1
	Circuit Description	2-2
SECTION 3	REPLACEABLE ELECTRICAL PARTS	
SECTION 4	DIAGRAMS	
SECTION 5	REPLACEABLE MECHANICAL PARTS	
CHANGE INFORMATION		

<http://www.ebsman.com>

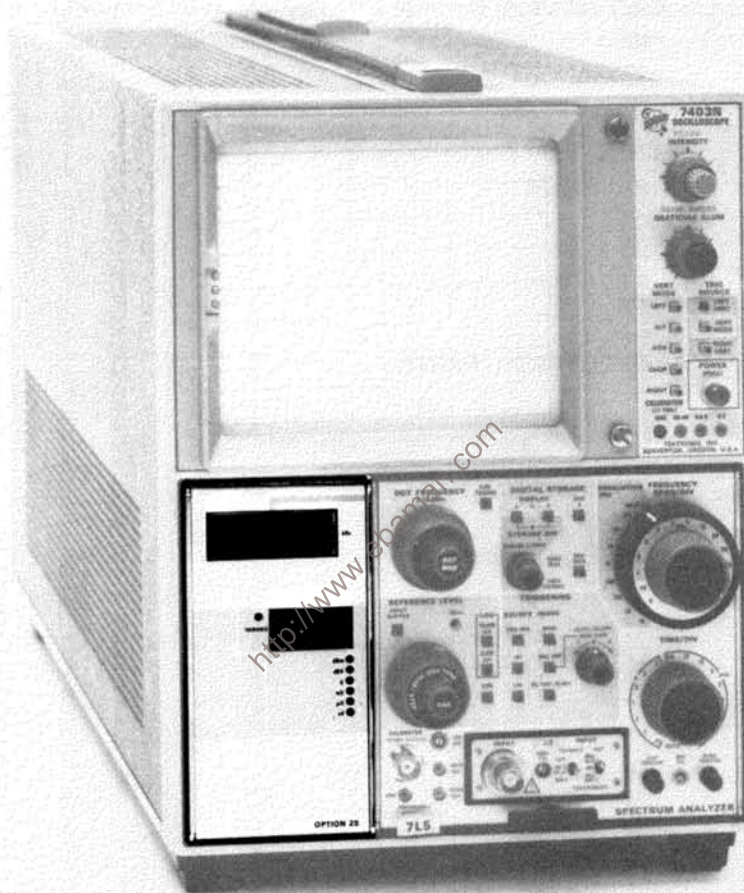

2155-1A

Fig. Option 28. 1-1. 7L5 Option 28 (Readout).

SPECIFICATIONS

GENERAL

Introduction

The 7L5 Option 28 provides reference level and dot frequency readout when it is installed and used in a 7000-Series mainframe that does not have crt readout. If the instrument is installed in a mainframe with readout, it will not affect the crt readout.

SPECIFICATIONS

There are no electrical characteristics. Environmental characteristics are the same as the 7000-Series mainframe.

STANDARD ACCESSORIES

Manual, Instruction

Initial Inspection and Installation

Refer to the Installation instructions at the beginning of the Options manual. These instructions are applicable for all options.

OPERATION

Front panel indicators are LED diodes that indicate; dBm, dBV, V, mV, μ V and nV. A light indicates when the 7L5 Variable Reference Level control is out of its Cal detent. Frequency and Reference Level are indicated by digital readout devices (six for frequency and four for reference level).

Since the Option 28 assembly has no electrical characteristics, only an operational check is required to verify performance. The following procedure checks operation:

1. Install the 7L5 Option 28 in a 7000-Series mainframe, without readout, and switch the Power On.
2. Check frequency and reference level readout operation by dialing or switching the 7L5 to various center frequencies and reference levels.
3. Switch the display mode from dBm to dBV to linear and check the reference level scaling indicators (dBm, dBV, V, mV, μ V, nV).

WARNING

THE FOLLOWING SERVICING INSTRUCTIONS ARE FOR USE BY QUALIFIED PERSONNEL ONLY. TO AVOID PERSONAL INJURY, DO NOT PERFORM ANY SERVICING OTHER THAN THAT CONTAINED IN OPERATING INSTRUCTIONS UNLESS YOU ARE QUALIFIED TO DO SO.

SERVICE INSTRUCTIONS

MAINTENANCE

Preventative maintenance plus troubleshooting techniques for the 7L5 are applicable for the Option 28 assembly. To prepare the assembly for service: 1) Turn the mainframe power off and remove the 7L5 Option 28 from the mainframe plug-in compartments. 2) Remove the snap-on sidepanel to expose the circuit board. 3) Connect the 7L5 Option 28 through flexible plug-in extenders (Calibration Fixture No. 067-0616-00) to the mainframe plug-in compartment or, pre-install the unit back in the mainframe plug-in compartment and remove the left sidepanel of the mainframe to gain access to the Option 28 adjustment. 4) Switch the mainframe power on and proceed with servicing the instrument. To remove the Option assembly, refer to replacement procedure for the Option 25 under its Maintenance Instructions.

CALIBRATION

There is only one calibration adjustment (R5305) for the Option 28 assembly. This adjusts the 0 to 9 scaling of A/D converter U5300.

With the Option 28 assembly and mainframe side panels removed, (see Maintenance) adjust R5305 (Fig. 2-1) so the readout scales correctly as the 7L5 Reference Level is switched in 1 dB steps from 0 through 9 dB.

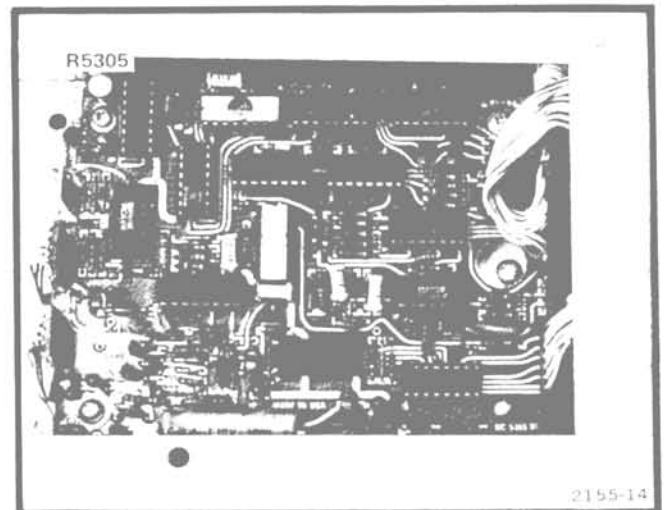

Fig. Option 28. 2-1. Adjustment location to calibrate the scaling.

CIRCUIT DESCRIPTION

The Option 28 circuitry contains both analog and digital circuits. The analog section converts an input column current, from the 7L5 or Tracking Generator (Option 25), to binary numbers for the frequency and reference level readout devices. The digital section contains an oscillator and a ring counter. The counter output sequentially enables the front panel readout devices and generates time slots that poll the 7L5 reference level and frequency readout. Time slots 1, 2, 3, and 4 poll the 7L5. When Option 28 is enabled, TS 7 is grounded to reduce crosstalk between the TS lines. TS 10 senses when the 7L5 Option 28 is installed in a readout or non-readout mainframe. This line is pulled low (down to approximately -15 V during its time period), if the 7L5 Option 28 is installed in a mainframe with readout. This charges C544 through VR 5444 and the resultant low generates a high out of U5341D which disables the Option 28 so the circuits will not interfere with the mainframe readout. TS 7 is grounded through Q5420 when the Option 28 is enabled. This transistor is turned on when the output of U5341D goes low.

The oscillator, consisting of active components U5331A and U5331F, generates the clock pulse for the digital circuitry. A ring counter (U5359, U5364) counts the clock frequency down. This output sequentially generates time slots and enables the readout devices. Counter U5359 counts from 0 through 7, with the 7th count disabling U5359 and enabling counter U5364. Counter U5364 then counts down through 16 (count of 9). The 9th count disables the counter and enables U5359 to repeat the process. Counts 1 through 6 (out of U5359) are applied through buffer amplifiers (Q5365, Q5370, Q5380, Q5390 and part of U5364) to sequentially enable the six frequency readout devices DS5002 through DS5012. Counts 2 through 5 (out of U5364) are applied through buffer amplifiers (within U5390) to sequentially enable the four reference level readout devices (DS5014 through DS5020).

Time slots 1, 2, and 3, for the 7L5 are generated during the 0 count from U5359 and the 1,2 count from U5364. Clock pulses out of U5341B are coupled through CR5402 to the enable (pin 1) four tri-state devices within U5336. The 0 count out of U5359 is applied through U5336(A) and VR5400 to transistor Q5400. During the enabling (clock) pulse period, TS 1 is generated. Time slot 2 (TS 2) and time slot 3 (TS 3) are generated in the same manner by the 1 and 2 count out of U5364. TS 4 is generated with every clock pulse except counts 1 and 2. When these two counts occur, they are gated through an OR gate (CR5382 CR5380) to the input of U5336B to disable Q5415.

The 8th count out of U5364 clocks a quad D flip-flop (U5394) to latch data to decoder U5392. The decoder output drives the scale factor LED's for the reference level readout.

The 7th count, which occurs near the end of the reference level readout, clocks U5398B. If the D input to U5398B is low (A/D converter U5300 output is 6) either the dBV or dBm LED is enabled by decoder U5392.

Input horizontal (dot frequency) and vertical (reference level) analog current, from the 7L5 (and Tracking Generator in the Option 33 assembly) is applied through multiplexer U5310 to the emitter of Q5305. This column current develops signal amplitudes of 0 to about 15 volts at TP305. This analog signal is then converted to digital data by U5300. The output of U5300 is converted to BCD by U5326, inverted by amplifiers U5331B-E then converted to a seven segment word by U5350. U5350 contains a converter and latch. This seven segment output is applied through buffer amplifiers (within U5354 and Q5350, Q5345) to the segment input of all the readout devices, except DS5014. This device displays only the minus (-) sign so only one segment is required.

Multiplexer U5310 inputs are driven by the 9th count out of U5364 and the Q output of the flip-flop U5398A. When the B input to U5310 is 1 (high), the multiplexer switches between the 7L5 horizontal and vertical column currents (2 & 3) as the 9th count (from U5364) cycles the A input. When A is 1 (high) the multiplexer looks at the 7L5 frequency information, when 0 (low), it looks at the 7L5 reference level information. Option 33 has both the Tracking Generator and Readout options. A pushbutton switch (S5042) is provided with this option, and when pushed, it clocks U5398A so the Q output goes low. Multiplexer U5310 now switches between the tracking generator reference level information and the 7L5 frequency information (0 and 1).

When the input column current to the multiplexer U5310 is $\geq 0.1\text{ mA}$ (valid), Q5300 turns on and generates a 1 at the D₁ input to U5394. This, along with the other three inputs, is clocked to the output and to a decoder U5392. The decoder output drives the reference level scale factor LED's. The output for each LED is shown within the decoder symbol, for example; dBV = 8 (1000), dBm = 9 (1001), V = 0 (000), etc.

REPLACEABLE ELECTRICAL PARTS

PARTS ORDERING INFORMATION

Replacement parts are available from or through your local Tektronix, Inc. Field Office or representative.

Changes to Tektronix instruments are sometimes made to accommodate improved components as they become available, and to give you the benefit of the latest circuit improvements developed in our engineering department. It is therefore important, when ordering parts, to include the following information in your order: Part number, instrument type or number, serial number, and modification number if applicable.

If a part you have ordered has been replaced with a new or improved part, your local Tektronix, Inc. Field Office or representative will contact you concerning any change in part number.

Change information, if any, is located at the rear of this manual.

SPECIAL NOTES AND SYMBOLS

X000 Part first added at this serial number
00X Part removed after this serial number

ITEM NAME

In the Parts List, an Item Name is separated from the description by a colon (:). Because of space limitations, an Item Name may sometimes appear as incomplete. For further Item Name identification, the U.S. Federal Cataloging Handbook H6-1 can be utilized where possible.

ABBREVIATIONS

ACTR	ACTUATOR	PLSTC	PLASTIC
ASSY	ASSEMBLY	QTZ	QUARTZ
CAP	CAPACITOR	RECP	RECEPTACLE
CER	CERAMIC	RES	RESISTOR
CKT	CIRCUIT	RF	RADIO FREQUENCY
COMP	COMPOSITION	SEL	SELECTED
CONN	CONNECTOR	SEMICOND	SEMICONDUCTOR
ELCTLT	ELECTROLYTIC	SENS	SENSITIVE
ELEC	ELECTRICAL	VAR	VARIABLE
INCAND	INCANDESCENT	WW	WIREWOUND
LED	LIGHT EMITTING DIODE	XFMR	TRANSFORMER
NONWIR	NON WIREWOUND	XTAL	CRYSTAL

CROSS INDEX—MFR. CODE NUMBER TO MANUFACTURER

Mfr. Code	Manufacturer	Address	City, State, Zip
0000L	MATSUSHITA ELECTRIC	200 PARK AVENUE, 54TH FLOOR	NEW YORK, NY 10017
01121	ALLEN-BRADLEY COMPANY	1201 2ND STREET SOUTH	MILWAUKEE, WI 53204
01295	TEXAS INSTRUMENTS, INC., SEMICONDUCTOR GROUP	P O BOX 5012, 13500 N CENTRAL EXPRESSWAY	DALLAS, TX 75222
02735	RCA CORPORATION, SOLID STATE DIVISION	ROUTE 202	SOMERVILLE, NY 08876
04222	AVX CERAMICS, DIVISION OF AVX CORP.	P O BOX 867, 19TH AVE. SOUTH	MYRTLE BEACH, SC 29577
07263	FAIRCHILD SEMICONDUCTOR, A DIV. OF FAIRCHILD CAMERA AND INSTRUMENT CORP.	464 ELLIS STREET	MOUNTAIN VIEW, CA 94042
32997	BOURNS, INC., TRIMPOT PRODUCTS DIV.	1200 COLUMBIA AVE.	RIVERSIDE, CA 92507
50579	LITRONIX INC.	19000 HOMESTEAD RD.	CUPERTINO, CA 95014
56289	SPRAGUE ELECTRIC CO.		NORTH ADAMS, MA 01247
72982	ERIE TECHNOLOGICAL PRODUCTS, INC.	644 W. 12TH ST.	ERIE, PA 16512
80009	TEKTRONIX, INC.	P O BOX 500	BEAVERTON, OR 97077
81483	INTERNATIONAL RECTIFIER CORP.	9220 SUNSET BLVD.	LOS ANGELES, CA 90069
91637	DALE ELECTRONICS, INC.	P. O. BOX 609	COLUMBUS, NE 68601

<http://www.ebaman.com>

Ckt No.	Tektronix Part No.	Serial/Model No. Eff	Dscont	Name & Description	Mfr Code	Mfr Part Number
A5002	670-4823-00			CKT BOARD ASSY:FRONT PANEL	80009	670-4823-00
A5250	670-4676-00			CKT BOARD ASSY:OPTION MAIN FRAME CONNECTOR	80009	670-4676-00
A5300	670-4781-00			CKT BOARD ASSY:READOUT LOGIC	80009	670-4781-00
C5300	283-0111-00			CAP., FXD, CER DI:0.1UF, 20%, 50V	72982	8121-N08825U104M
C5301	283-0060-00			CAP., FXD, CER DI:100PF, 5%, 200V	72982	855-535U2J101J
C5302	281-0580-00			CAP., FXD, CER DI:470PF, 10%, 500V	04222	7001-1374
C5320	281-0536-00			CAP., FXD, CER DI:1000PF, 10%, 500V	72982	301000 X5P0 102K
C5324	281-0638-00			CAP., FXD, CER DI:240PF, 5%, 500V	72982	301000Z5D241J
C5364	283-0204-00			CAP., FXD, CER DI:0.01UF, 20%, 50V	72982	8121N061Z5U0103M
C5367	283-0204-00			CAP., FXD, CER DI:0.01UF, 20%, 50V	72982	8121N061Z5U0103M
C5370	283-0058-00			CAP., FXD, CER DI:0.027UF, 10%, 100V	72982	8131N147X7R0273K
C5394	281-0580-00			CAP., FXD, CER DI:470PF, 10%, 500V	04222	7001-1374
C5396	281-0580-00			CAP., FXD, CER DI:470PF, 10%, 500V	04222	7001-1374
C5398	290-0534-00			CAP., FXD, ELCTLT:1UF, 20%, 35V	56289	196D105X0035HA1
C5399	283-0059-00			CAP., FXD, CER DI:1UF, +80-20%, 25V	72982	8131N031Z5U0105Z
C5400	281-0580-00			CAP., FXD, CER DI:470PF, 10%, 500V	04222	7001-1374
C5423	283-0010-00			CAP., FXD, CER DI:0.05UF, +100-20%, 50V	56289	273C20
C5424	283-0010-00			CAP., FXD, CER DI:0.05UF, +100-20%, 50V	56289	273C20
C5426	283-0010-00			CAP., FXD, CER DI:0.05UF, +100-20%, 50V	56289	273C20
C5428	290-0534-00			CAP., FXD, ELCTLT:1UF, 20%, 35V	56289	196D105X0035HA1
C5430	283-0010-00			CAP., FXD, CER DI:0.05UF, +100-20%, 50V	56289	273C20
C5432	290-0534-00			CAP., FXD, ELCTLT:1UF, 20%, 35V	56289	196D105X0035HA1
C5434	283-0010-00			CAP., FXD, CER DI:0.05UF, +100-20%, 50V	56289	273C20
C5436	283-0059-00			CAP., FXD, CER DI:1UF, +80-20%, 25V	72982	8131N031Z5U0105Z
C5438	283-0010-00			CAP., FXD, CER DI:0.05UF, +100-20%, 50V	56289	273C20
C5440	283-0010-00			CAP., FXD, CER DI:0.05UF, +100-20%, 50V	56289	273C20
C5442	290-0773-00			CAP., FXD, ELCTLT:1000UF, +50-10%, 10V	0000L	ECE-B10Z1000
C5444	283-0111-00			CAP., FXD, CER DI:0.1UF, 20%, 50V	72982	8121-N08825U104M
C5470	283-0059-00			CAP., FXD, CER DI:1UF, +80-20%, 25V	72982	8131N031Z5U0105Z
CR5010	150-1050-00			LT EMITTING DIO:RED	50579	RL-T1
CR5030	150-1050-00			LT EMITTING DIO:RED	50579	RL-T1
CR5032	150-1050-00			LT EMITTING DIO:RED	50579	RL-T1
CR5034	150-1050-00			LT EMITTING DIO:RED	50579	RL-T1
CR5036	150-1050-00			LT EMITTING DIO:RED	50579	RL-T1
CR5038	150-1050-00			LT EMITTING DIO:RED	50579	RL-T1
CR5040	150-1050-00			LT EMITTING DIO:RED	50579	RL-T1
CR5300	152-0141-02			SEMICONV DEVICE:SILICON, 30V, 150MA	80009	152-0141-02
CR5306	152-0141-02			SEMICONV DEVICE:SILICON, 30V, 150MA	80009	152-0141-02
CR5310	152-0141-02			SEMICONV DEVICE:SILICON, 30V, 150MA	80009	152-0141-02
CR5312	152-0141-02			SEMICONV DEVICE:SILICON, 30V, 150MA	80009	152-0141-02
CR5314	152-0141-02			SEMICONV DEVICE:SILICON, 30V, 150MA	80009	152-0141-02
CR5316	152-0141-02			SEMICONV DEVICE:SILICON, 30V, 150MA	80009	152-0141-02
CR5320	152-0141-02			SEMICONV DEVICE:SILICON, 30V, 150MA	80009	152-0141-02
CR5324	152-0141-02			SEMICONV DEVICE:SILICON, 30V, 150MA	80009	152-0141-02
CR5359	152-0141-02			SEMICONV DEVICE:SILICON, 30V, 150MA	80009	152-0141-02
CR5364	152-0141-02			SEMICONV DEVICE:SILICON, 30V, 150MA	80009	152-0141-02
CR5380	152-0141-02			SEMICONV DEVICE:SILICON, 30V, 150MA	80009	152-0141-02
CR5382	152-0141-02			SEMICONV DEVICE:SILICON, 30V, 150MA	80009	152-0141-02
CR5398	152-0141-02			SEMICONV DEVICE:SILICON, 30V, 150MA	80009	152-0141-02
CR5402	152-0141-02			SEMICONV DEVICE:SILICON, 30V, 150MA	80009	152-0141-02
CR5420	152-0141-02			SEMICONV DEVICE:SILICON, 30V, 150MA	80009	152-0141-02
CR5422	152-0141-02			SEMICONV DEVICE:SILICON, 30V, 150MA	80009	152-0141-02
CR5424	152-0141-02			SEMICONV DEVICE:SILICON, 30V, 150MA	80009	152-0141-02
CR5444	152-0141-02			SEMICONV DEVICE:SILICON, 30V, 150MA	80009	152-0141-02

Replaceable Electrical Parts—7L5 Option 28

Ckt No.	Tektronix Part No.	Serial/Model No. Eff	Dscont	Name & Description	Mfr Code	Mfr Part Number
DS5002	150-1011-01			LAMP, LED, RDOUT: RED SINGLE DIGIT	07263	FND 357
DS5004	150-1011-01			LAMP, LED, RDOUT: RED SINGLE DIGIT	07263	FND 357
DS5006	150-1011-01			LAMP, LED, RDOUT: RED SINGLE DIGIT	07263	FND 357
DS5008	150-1011-01			LAMP, LED, RDOUT: RED SINGLE DIGIT	07263	FND 357
DS5010	150-1011-01			LAMP, LED, RDOUT: RED SINGLE DIGIT	07263	FND 357
DS5012	150-1011-01			LAMP, LED, RDOUT: RED SINGLE DIGIT	07263	FND 357
DS5014	150-1011-01			LAMP, LED, RDOUT: RED SINGLE DIGIT	07263	FND 357
DS5016	150-1011-01			LAMP, LED, RDOUT: RED SINGLE DIGIT	07263	FND 357
DS5018	150-1011-01			LAMP, LED, RDOUT: RED SINGLE DIGIT	07263	FND 357
DS5020	150-1011-01			LAMP, LED, RDOUT: RED SINGLE DIGIT	07263	FND 357
L5398	108-0598-00			COIL, RF: 200UH	80009	108-0598-00
L5426	108-0598-00			COIL, RF: 200UH	80009	108-0598-00
L5428	108-0598-00			COIL, RF: 200UH	80009	108-0598-00
L5430	108-0598-00			COIL, RF: 200UH	80009	108-0598-00
Q5300	151-0188-00			TRANSISTOR: SILICON, PNP	80009	151-0188-00
Q5305	151-0190-00			TRANSISTOR: SILICON, NPN	80009	151-0190-00
Q5345	151-0190-00			TRANSISTOR: SILICON, NPN	80009	151-0190-00
Q5350	151-0190-00			TRANSISTOR: SILICON, NPN	80009	151-0190-00
Q5365	151-0190-00			TRANSISTOR: SILICON, NPN	80009	151-0190-00
Q5370	151-0190-00			TRANSISTOR: SILICON, NPN	80009	151-0190-00
Q5375	151-0190-00			TRANSISTOR: SILICON, NPN	80009	151-0190-00
Q5380	151-0190-00			TRANSISTOR: SILICON, NPN	80009	151-0190-00
Q5382	151-0188-00			TRANSISTOR: SILICON, PNP	80009	151-0188-00
Q5390	151-0190-00			TRANSISTOR: SILICON, NPN	80009	151-0190-00
Q5400	151-0190-00			TRANSISTOR: SILICON, NPN	80009	151-0190-00
Q5405	151-0190-00			TRANSISTOR: SILICON, NPN	80009	151-0190-00
Q5410	151-0190-00			TRANSISTOR: SILICON, NPN	80009	151-0190-00
Q5415	151-0190-00			TRANSISTOR: SILICON, NPN	80009	151-0190-00
Q5420	151-0188-00			TRANSISTOR: SILICON, PNP	80009	151-0188-00
R5004	315-0471-00			RES., FXD, CMPSN: 470 OHM, 5%, 0.25W	01121	CB4715
R5300	315-0153-00			RES., FXD, CMPSN: 15K OHM, 5%, 0.25W	01121	CB1535
R5302	321-0258-00			RES., FXD, FILM: 4.75K OHM, 1%, 0.125W	91637	MFF1816G47500F
R5304	315-0102-00			RES., FXD, CMPSN: 1K OHM, 5%, 0.25W	01121	CB1025
R5305	311-1263-00			RES., VAR, NONWIR: 1K OHM, 10%, 0.50W	32997	3329P-L58-102
R5306	315-0104-00			RES., FXD, CMPSN: 100K OHM, 5%, 0.25W	01121	CB1045
R5308	315-0244-00			RES., FXD, CMPSN: 240K OHM, 5%, 0.25W	01121	CB2445
R5310	315-0103-00			RES., FXD, CMPSN: 10K OHM, 5%, 0.25W	01121	CB1035
R5312	315-0103-00			RES., FXD, CMPSN: 10K OHM, 5%, 0.25W	01121	CB1035
R5318	315-0471-00			RES., FXD, CMPSN: 470 OHM, 5%, 0.25W	01121	CB4715
R5320	315-0204-00			RES., FXD, CMPSN: 200K OHM, 5%, 0.25W	01121	CB2045
R5322	315-0104-00			RES., FXD, CMPSN: 100K OHM, 5%, 0.25W	01121	CB1045
R5324	315-0203-00			RES., FXD, CMPSN: 20K OHM, 5%, 0.25W	01121	CB2035
R5326	315-0103-00			RES., FXD, CMPSN: 10K OHM, 5%, 0.25W	01121	CB1035
R5345	315-0100-00			RES., FXD, CMPSN: 10 OHM, 5%, 0.25W	01121	CB1005
R5348	315-0100-00			RES., FXD, CMPSN: 10 OHM, 5%, 0.25W	01121	CB1005
R5349	315-0100-00			RES., FXD, CMPSN: 10 OHM, 5%, 0.25W	01121	CB1005
R5350	315-0100-00			RES., FXD, CMPSN: 10 OHM, 5%, 0.25W	01121	CB1005
R5351	315-0100-00			RES., FXD, CMPSN: 10 OHM, 5%, 0.25W	01121	CB1005
R5352	315-0100-00			RES., FXD, CMPSN: 10 OHM, 5%, 0.25W	01121	CB1005
R5353	315-0100-00			RES., FXD, CMPSN: 10 OHM, 5%, 0.25W	01121	CB1005
R5356	315-0102-00			RES., FXD, CMPSN: 1K OHM, 5%, 0.25W	01121	CB1025
R5357	315-0102-00			RES., FXD, CMPSN: 1K OHM, 5%, 0.25W	01121	CB1025
R5358	315-0102-00			RES., FXD, CMPSN: 1K OHM, 5%, 0.25W	01121	CB1025
R5359	315-0103-00			RES., FXD, CMPSN: 10K OHM, 5%, 0.25W	01121	CB1035
R5360	315-0102-00			RES., FXD, CMPSN: 1K OHM, 5%, 0.25W	01121	CB1025

Ckt No.	Tektronix Part No.	Serial/Model No. Eff	Dscont	Name & Description	Mfr Code	Mfr Part Number
R5361	315-0102-00			RES., FXD, CMPSN: 1K OHM, 5%, 0.25W	01121	CB1025
R5362	315-0102-00			RES., FXD, CMPSN: 1K OHM, 5%, 0.25W	01121	CB1025
R5363	315-0102-00			RES., FXD, CMPSN: 1K OHM, 5%, 0.25W	01121	CB1025
R5364	315-0103-00			RES., FXD, CMPSN: 10K OHM, 5%, 0.25W	01121	CB1035
R5365	315-0102-00			RES., FXD, CMPSN: 1K OHM, 5%, 0.25W	01121	CB1025
R5370	315-0222-00			RES., FXD, CMPSN: 2.2K OHM, 5%, 0.25W	01121	CB2225
R5371	315-0102-00			RES., FXD, CMPSN: 1K OHM, 5%, 0.25W	01121	CB1025
R5372	315-0105-00			RES., FXD, CMPSN: 1M OHM, 5%, 0.25W	01121	CB1055
R5375	315-0111-00			RES., FXD, CMPSN: 110 OHM, 5%, 0.25W	01121	CB1115
R5375	315-0102-00			RES., FXD, CMPSN: 1K OHM, 5%, 0.25W	01121	CB1025
R5377	315-0331-00			RES., FXD, CMPSN: 330 OHM, 5%, 0.25W	01121	CB3315
R5380	315-0102-00			RES., FXD, CMPSN: 1K OHM, 5%, 0.25W	01121	CB1025
R5381	315-0102-00			RES., FXD, CMPSN: 1K OHM, 5%, 0.25W	01121	CB1025
R5382	315-0102-00			RES., FXD, CMPSN: 1K OHM, 5%, 0.25W	01121	CB1025
R5385	315-0510-00			RES., FXD, CMPSN: 51 OHM, 5%, 0.25W	01121	CB5105
R5387	315-0513-00			RES., FXD, CMPSN: 51K OHM, 5%, 0.25W	01121	CB5135
R5389	315-0512-00			RES., FXD, CMPSN: 5.1K OHM, 5%, 0.25W	01121	CB5125
R5390	315-0102-00			RES., FXD, CMPSN: 1K OHM, 5%, 0.25W	01121	CB1025
R5394	315-0244-00			RES., FXD, CMPSN: 240K OHM, 5%, 0.25W	01121	CB2445
R5396	315-0244-00			RES., FXD, CMPSN: 240K OHM, 5%, 0.25W	01121	CB2445
R5398	315-0472-00			RES., FXD, CMPSN: 4.7K OHM, 5%, 0.25W	01121	CB4725
R5399	315-0104-00			RES., FXD, CMPSN: 100K OHM, 5%, 0.25W	01121	CB1045
R5402	315-0513-00			RES., FXD, CMPSN: 51K OHM, 5%, 0.25W	01121	CB5135
R5420	315-0513-00			RES., FXD, CMPSN: 51K OHM, 5%, 0.25W	01121	CB5135
R5444	315-0103-00			RES., FXD, CMPSN: 10K OHM, 5%, 0.25W	01121	CB1035
R5446	315-0105-00			RES., FXD, CMPSN: 1M OHM, 5%, 0.25W	01121	CB1055
R5448	315-0203-00			RES., FXD, CMPSN: 20K OHM, 5%, 0.25W	01121	CB2035
U5300	155-0014-01			MICROCIRCUIT, DI: ML, ANALOG TO DECIMAL CONV	80009	155-0014-01
U5310	156-0513-00			MICROCIRCUIT, DI: 8-CHAN MUX	80009	156-0513-00
U5326	156-0347-00			MICROCIRCUIT, DI: 10-LINE TO 4-LINE ENCODER	01295	SN74147N
U5331	156-0494-00			MICROCIRCUIT, DI: HEX INVERTER/BUFFER	80009	156-0494-00
U5336	156-0649-00			MICROCIRCUIT, DI: 3 STATE HEX. NON INVT BFR	80009	156-0649-00
U5341	156-0494-00			MICROCIRCUIT, DI: HEX INVERTER/BUFFER	80009	156-0494-00
U5350	156-0493-00			MICROCIRCUIT, DI: BCD TO 7 SEG DEC/DRIVER	07263	9368DC
U5354	156-0259-00			MICROCIRCUIT, LI: 5 TRANSISTOR ARRAY	80009	156-0259-00
U5359	156-0799-00			MICROCIRCUIT, DI: DECADE CNTR/DTV	80009	156-0799-00
U5364	156-0799-00			MICROCIRCUIT, DI: DECADE CNTR/DTV	80009	156-0799-00
U5390	156-0355-00			MICROCIRCUIT, LI: 7-XSTR, COMMON EMITTER	02735	CA3081
U5392	156-0111-00			MICROCIRCUIT, DI: SGL BCD-TO-DEC DEC/DRIVER	80009	156-0111-00
U5394	156-0682-00			MICROCIRCUIT, DI: HEX D FLIP-FLOP	80009	156-0682-00
U5398	156-0366-00			MICROCIRCUIT, DI: DUAL D-TYPE F-F	80009	156-0366-00
VR5400	152-0571-00			SEMICONV DEVICE: ZENER, 0.4W, 16V, 5%	80009	152-0571-00
VR5405	152-0571-00			SEMICONV DEVICE: ZENER, 0.4W, 16V, 5%	80009	152-0571-00
VR5410	152-0571-00			SEMICONV DEVICE: ZENER, 0.4W, 16V, 5%	80009	152-0571-00
VR5415	152-0571-00			SEMICONV DEVICE: ZENER, 0.4W, 16V, 5%	80009	152-0571-00
VR5444	152-0166-00			SEMICONV DEVICE: ZENER, 0.4W, 6.2V, 5%	81483	69-941

DIAGRAM AND CIRCUIT BOARD ILLUSTRATION

Symbols and Reference Designators

Graphic symbols for electrical and logic symbols, used on the diagrams, are based on ANSI Y32.2, 1970, and ANSI Y32.14, 1973, "American National Standards Institute." Logic symbols depict the logic function of the device in positive logic. Copies of these standards can be obtained from the Institute of Electrical and Electronics Engineers, 345 East 47th Street, New York, N.Y., 11017. Exceptions and additions are shown on this sample diagram. These conform or are based on the manufacturers data sheet and industry trends.

Resistor values are in ohms, unless noted otherwise, and the Ω symbol is omitted. Capacitor values ≥ 1 (e.g. 10) are in picofarads (pF) and values < 1 (e.g. 0.01) are in microfarads unless otherwise noted.

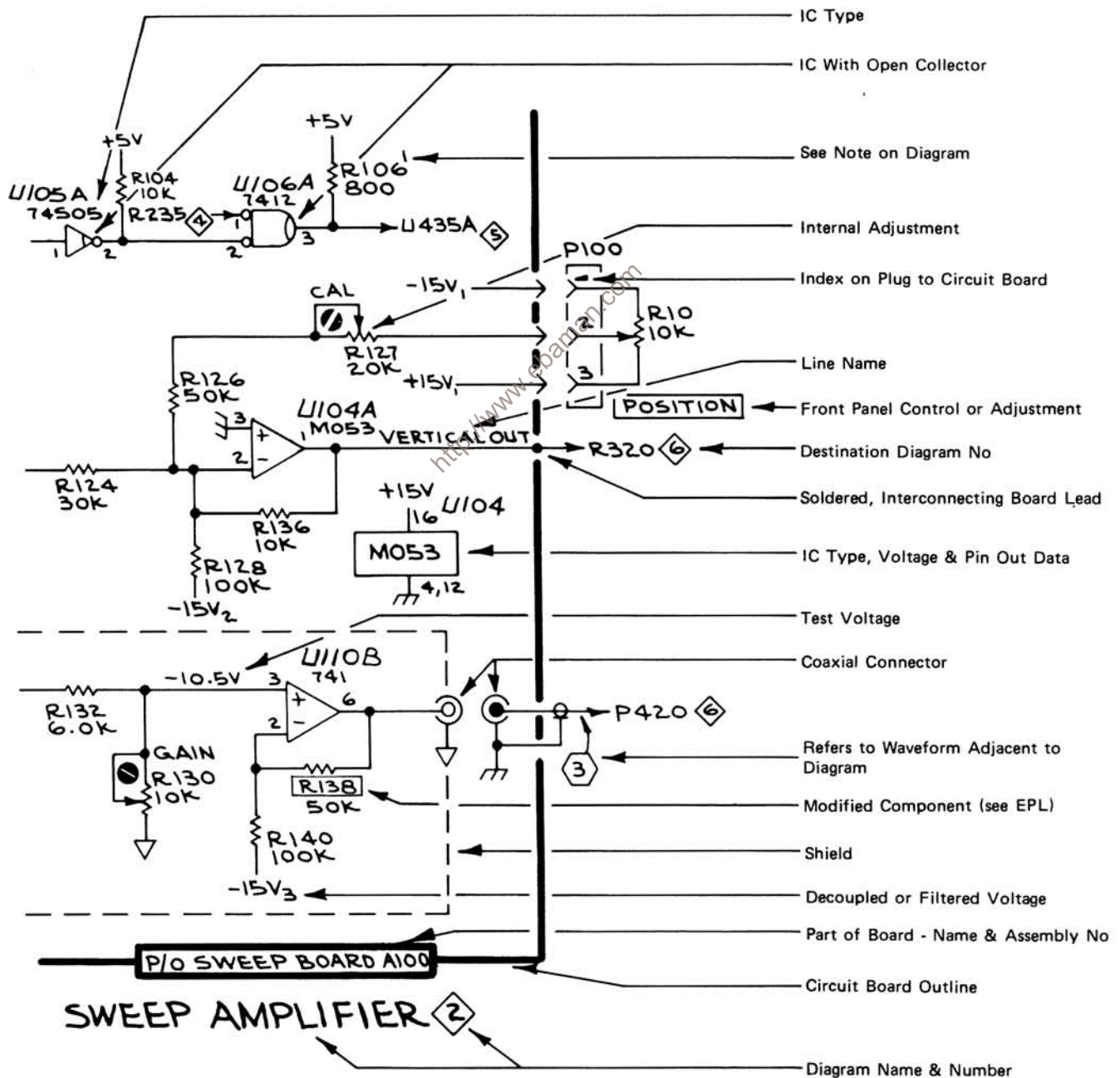

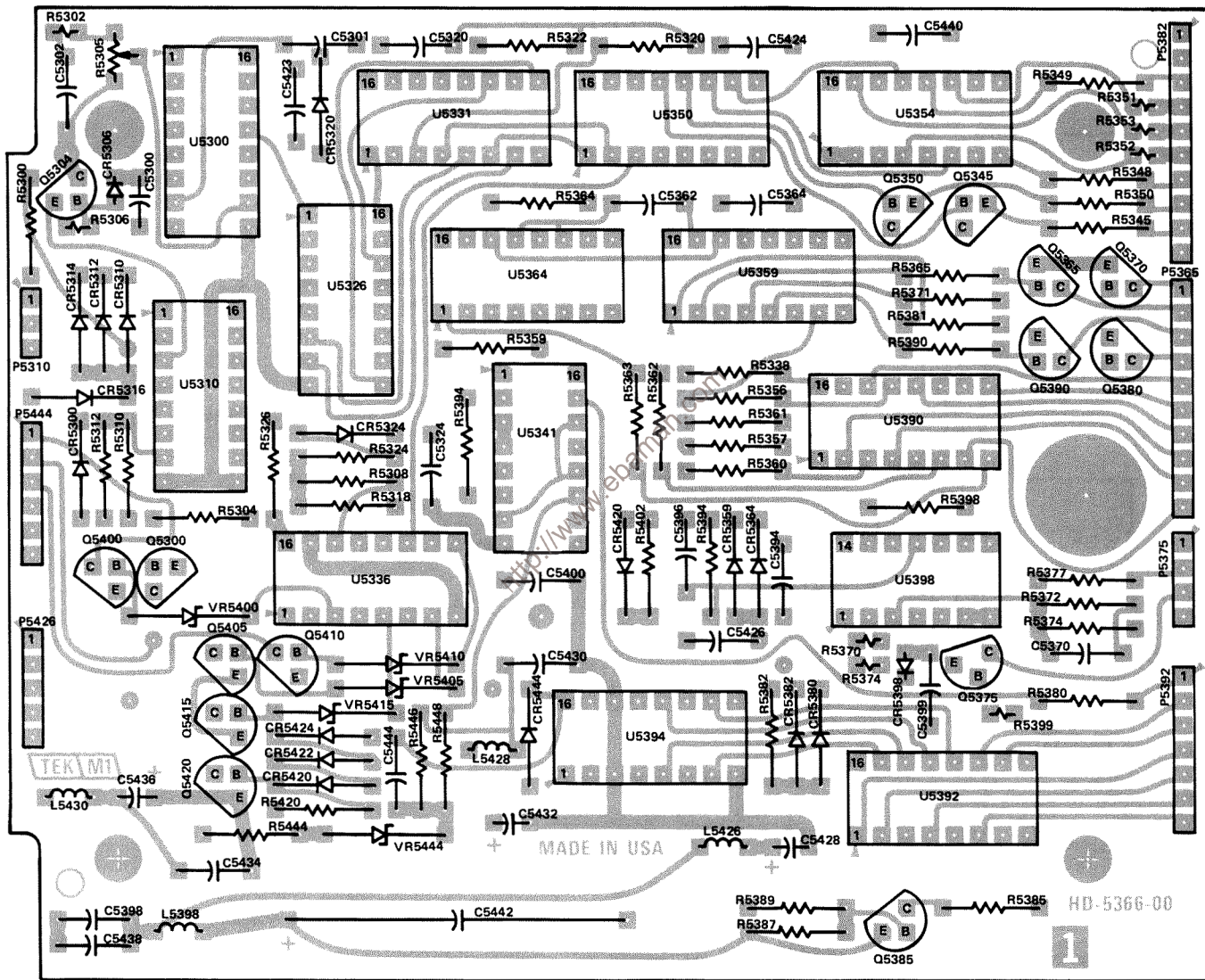

A5300 Readout Logic.

REPLACEABLE MECHANICAL PARTS

PARTS ORDERING INFORMATION

Replacement parts are available from or through your local Tektronix, Inc. Field Office or representative.

Changes to Tektronix instruments are sometimes made to accommodate improved components as they become available, and to give you the benefit of the latest circuit improvements developed in our engineering department. It is therefore important, when ordering parts, to include the following information in your order: Part number, instrument type or number, serial number, and modification number if applicable.

If a part you have ordered has been replaced with a new or improved part, your local Tektronix, Inc. Field Office or representative will contact you concerning any change in part number.

Change information, if any, is located at the rear of this manual.

SPECIAL NOTES AND SYMBOLS

X000 Part first added at this serial number
00X Part removed after this serial number

FIGURE AND INDEX NUMBERS

Items in this section are referenced by figure and index numbers to the illustrations.

INDENTATION SYSTEM

This mechanical parts list is indented to indicate item relationships. Following is an example of the indentation system used in the description column.

```

1 2 3 4 5           Name & Description
Assembly and/or Component
Attaching parts for Assembly and/or Component
    --- * ---
Detail Part of Assembly and/or Component
Attaching parts for Detail Part
    --- * ---
Parts of Detail Part
Attaching parts for Parts of Detail Part
    --- * ---
  
```

Attaching Parts always appear in the same indentation as the item it mounts, while the detail parts are indented to the right. Indented items are part of, and included with, the next higher indentation. The separation symbol --- * --- indicates the end of attaching parts.

Attaching parts must be purchased separately, unless otherwise specified.

ITEM NAME

In the Parts List, an Item Name is separated from the description by a colon (:). Because of space limitations, an Item Name may sometimes appear as incomplete. For further Item Name identification, the U.S. Federal Cataloging Handbook H6-1 can be utilized where possible.

ABBREVIATIONS

INCH	ELECTRN	ELECTRON	IN	INCH	SE	SINGLE END
# NUMBER SIZE	ELEC	ELECTRICAL	INCAND	INCANDESCENT	SECT	SECTION
ACTR ACTUATOR	ELCTLT	ELECTROLYTIC	INSUL	INSULATOR	SEMICON	SEMICONDUCTOR
ADPTR ADAPTER	ELEM	ELEMENT	INTL	INTERNAL	SHLD	SHIELD
ALIGN ALIGNMENT	EPL	ELECTRICAL PARTS LIST	LPHLDR	LAMPHOLDER	SHLDR	SHOULDERED
AL ALUMINUM	EQPT	EQUIPMENT	MACH	MACHINE	SKT	SOCKET
ASSEM ASSEMBLED	EXT	EXTERNAL	MECH	MECHANICAL	SL	SLIDE
ASSY ASSEMBLY	FIL	FILLISTER HEAD	MTG	MOUNTING	SLFLKG	SELF-LOCKING
ATTEN ATTENUATOR	FLEX	FLEXIBLE	NIP	NIPPLE	SLVG	SLEEVING
AWG AMERICAN WIRE GAGE	FLH	FLAT HEAD	NON WIRE	NOT WIRE WOUND	SPR	SPRING
BD BOARD	FLTR	FILTER	OBD	ORDER BY DESCRIPTION	SO	SQUARE
BRKT BRACKET	FR	FRAME or FRONT	OD	OUTSIDE DIAMETER	SST	STAINLESS STEEL
BRS BRASS	FSTNR	FASTENER	OVH	OVAL HEAD	STL	STEEL
BRZ BRONZE	FT	FOOT	PH BRZ	PHOSPHOR BRONZE	SW	SWITCH
BSHG BUSHING	FXD	FIXED	PL	PLAIN or PLATE	T	TUBE
CAB CABINET	GSKT	GASKET	PLSTC	PLASTIC	TERM	TERMINAL
CAP CAPACITOR	HDL	HANDLE	PN	PART NUMBER	THD	THREAD
CER CERAMIC	HEX	HEXAGON	PNH	PAN HEAD	THK	THICK
CHAS CHASSIS	HEX HD	HEXAGONAL HEAD	PWR	POWER	TNSN	TENSION
CKT CIRCUIT	HEX SOC	HEXAGONAL SOCKET	RCPT	RECEPTACLE	TPG	TAPPING
COMP COMPOSITION	HLCPS	HELICAL COMPRESSION	RES	RESISTOR	TRH	TRUSS HEAD
CONN CONNECTOR	HLEXT	HELICAL EXTENSION	RGD	RIGID	V	VOLTAGE
COV COVER	HV	HIGH VOLTAGE	RLF	RELIEF	VAR	VARIABLE
CPLG COUPLING	IC	INTEGRATED CIRCUIT	RTNR	RETAINER	W/	WITH
CRT CATHODE RAY TUBE	ID	INSIDE DIAMETER	SCH	SOCKET HEAD	WSHR	WASHER
DEG DEGREE	IDNT	IDENTIFICATION	SCOPE	OSCILLOSCOPE	XFMR	TRANSFORMER
DWR DRAWER	IMPLR	IMPELLER	SCR	SCREW	XSTR	TRANSISTOR

CROSS INDEX—MFR. CODE NUMBER TO MANUFACTURER

Mfr. Code	Manufacturer	Address	City, State, Zip
01295	TEXAS INSTRUMENTS, INC., SEMICONDUCTOR GROUP	P O BOX 5012, 13500 N CENTRAL EXPRESSWAY	DALLAS, TX 75222
08261	SPECTRA-STRIP CORP.	7100 LAMPSON AVE.	GARDEN GROVE, CA 92642
13257	AMERACE, LTD.	10 ESNA PARK DRIVE	MARKHAM, ONTARIO, CANADA
22526	BERG ELECTRONICS, INC.	YOUK EXPRESSWAY	NEW CUMBERLAND, PA 17070
80009	TEKTRONIX, INC.	P O BOX 500	BEAVERTON, OR 97077
82647	TEXAS INSTRUMENTS, INC., CONTROL PRODUCTS DIV.	34 FOREST ST.	ATTLEBORO, MA 02703
83385	CENTRAL SCREW CO.	2530 CRESCENT DR.	BROADVIEW, IL 60153
86445	PENN FIBRE AND SPECIALTY CO., INC.	2032 E. WESTMORELAND ST.	PHILADELPHIA, PA 19134
87308	N. L. INDUSTRIES, INC., SOUTHERN SCREW DIV.	P. O. BOX 1360	STATESVILLE, NC 28677

<http://www.ebaman.com>

Fig. & Index No.	Tektronix Part No.	Serial/Model No. Eff Dscont	Qty	1 2 3 4 5	Name & Description	Mfr Code	Mfr Part Number
1-1	337-1064-09		1		SHIELD,ELEC:LEFT SIDE	80009	337-1064-09
-2	333-2239-00		1		PANEL,FRONT:	80009	333-2239-00
-3	378-0859-00		1		FILTER,LIGHT:RED,1.775 L X0.575 W	80009	378-0859-00
-4	378-0860-00		1		FILTER,LIGHT:RED,1.175 L X0.575 W	80009	378-0860-00
-5	348-0235-00		2		SHLD GSKT,ELEC:4.734 INCH LONG	80009	348-0235-00
-6	-----		1		CKT BOARD ASSY:FRONT PANEL(SEE A5002 EPL) (ATTACHING PARTS)		
-7	211-0116-00		4		SCR,ASSEM WSHR:4-40 X 0.312 INCH,PNH BRS - - - * - - -	83385	OBD
	-----		-		. CKT BOARD ASSY INCLUDES:		
-8	388-5253-00		3		. CKT BOARD:SWITCH MODULE	80009	388-5253-00
-9	361-0814-00		6		. SPACER,CKT CARD:	80009	361-0814-00
-10	131-0608-00		50		. TERMINAL,PIN:0.365 L X 0.25 PH,BRZ,GOLD PL	22526	47357
-11	386-1447-84		1		SUBPANEL,FRONT: (ATTACHING PARTS)	80009	386-1447-84
-12	213-0192-00		4		SCR,TPG,THD FOR:6-32 X 0.50 INCH,PNH STL - - - * - - -	87308	OBD
-13	-----		1		CKT BOARD ASSY:READOUT(SEE A5300 EPL) (ATTACHING PARTS)		
-14	211-0007-00		4		SCREW,MACHINE:4-40 X 0.188 INCH,PNH STL - - - * - - -	83385	OBD
	-----		-		. CKT BOARD ASSY INCLUDES:		
-15	136-0252-04		45		. SOCKET,PIN TERM:0.188 INCH LONG	22526	75060
-16	131-0608-00		46		. TERMINAL,PIN:0.365 L X 0.25 PH,BRZ,GOLD PL	22526	47357
-17	214-0579-00		2		. TERM.,TEST PT:BRS CD PL	80009	214-0579-00
-18	136-0260-02		13		. SOCKET,PLUG-IN:16 CONTACT,LOW CLEARANCE	82647	C9316-18
-19	136-0269-02		1		. SOCKET,PLUG-IN:14 CONTACT,LOW CLEARANCE	01295	C95140
-20	129-0236-01		4		SPACER,POST:0.375 L W/4-40 EXT THD ONE END	80009	129-0236-01
-21	211-0001-00		2		SCREW,MACHINE:2-56 X 0.25 INCH,PNH STL	83385	OBD
-22	407-1878-00		1		BRACKET,ANGLE:ALUMINUM (ATTACHING PARTS)	80009	407-1878-00
-23	211-0529-00		1		SCREW,MACHINE:6-32 X 1.25 INCHES,PNH STL - - - * - - -	83385	OBD
-24	200-2060-00		1		COVER,TOP: (ATTACHING PARTS)	80009	200-2060-00
-25	211-0007-00		10		SCREW,MACHINE:4-40 X 0.188 INCH,PNH STL - - - * - - -	83385	OBD
-26	441-1352-00		1		CHAS,PL-IN UNIT:CIRCUIT CARDS (ATTACHING PARTS)	80009	441-1352-00
-27	211-0025-00		6		SCREW,MACHINE:4-40 X 0.375 100 DEG,FLH STL - - - * - - -	83385	OBD
-28	-----		1		CKT BOARD ASSY:MNFRM INTFC(SEE 5250 EPL)		
-29	131-0827-00		10		. CONTACT,ELEC:0.55 INCH LONG	22526	47349
-30	131-0608-00		45		. TERMINAL,PIN:0.365 L X 0.25 PH,BRZ,GOLD PL	22526	47357
-31	351-0217-01		1		GUIDE,CKT CARD:PLASTIC (ATTACHING PARTS)	80009	351-0217-01
-32	220-0557-00		4		NUT SLEEVE:6-32 X 0.204 OD X 0.118 L BRS	80009	220-0557-00
-33	211-0507-00		4		SCREW,MACHINE:6-32 X 0.312 INCH,PNH STL - - - * - - -	83385	OBD
-34	386-3636-00		1		PANEL,REAR: (ATTACHING PARTS)	80009	386-3636-00
-35	213-0192-00		2		SCR,TPG,THD FOR:6-32 X 0.50 INCH,PNH STL	87308	OBD
-36	210-0589-00		2		NUT,SELF LKG HE:4-40 X 0.250 INCH	13257	22 NM-40
-37	210-1160-00		2		WASHER,NONMETAL:0.109 ID X 0.25 INCH OD	86445	OBD
-38	211-0012-00		2		SCREW,MACHINE:4-40 X 0.375 INCH,PNH STL - - - * - - -	83385	OBD
-39	426-1343-00		1		FR SECT,PLUG-IN:TOP	80009	426-1343-00
-40	426-1344-00		1		FR SECT,PLUG-IN:BOTTOM	80009	426-1344-00
	198-3393-00		1		WIRE SET,ELEC:	80009	198-3393-00
-41	175-0825-00		FT		. WIRE,ELECTRICAL:2 WIRE RIBBON	80009	175-0825-00
-42	175-0828-00		FT		. WIRE,ELECTRICAL:5 WIRE RIBBON	08261	OBD
-43	175-0829-00		FT		. WIRE,ELECTRICAL:6 WIRE RIBBON	08261	SS-0626-710610C
-44	175-0830-00		FT		. WIRE,ELECTRICAL:7 WIRE RIBBON	08261	SS-0726-710610C
-45	175-0855-00		FT		. WIRE,ELECTRICAL:10 WIRE RIBBON	08261	SS-1022(1061)0C

Replaceable Mechanical Parts—7L5 Option 28

Fig. & Index No.	Tektronix Part No.	Serial/Model No. Eff	Dscont	Qty	1	2	3	4	5	Name & Description	Mfr Code	Mfr Part Number
1-46	131-0707-00			92	.					CONNECTOR, TERM.: 22-26 AWG, BRS& CU BE GOLD	22526	47439
-47	352-0161-04			1	.					CONN BODY, PL, EL: 3 WIRE YELLOW	80009	352-0161-04
-48	352-0163-06			2	.					CONN BODY, PL, EL: 5 WIRE BLUE	80009	352-0163-06
-49	352-0164-05			1	.					CONN BODY, PL, EL: 6 WIRE GREEN	80009	352-0164-05
-50	352-0165-01			2	.					CONN BODY, PL, EL: 7 WIRE BROWN	80009	352-0165-01
-51	352-0168-01			1	.					CONN BODY, PL, EL: 10 WIRE BROWN	80009	352-0168-01
	352-0168-02			3	.					CONN BODY, PL, EL: 10 WIRE RED	80009	352-0168-02
	352-0168-03			2	.					CONN BODY, PL, EL: 10 WIRE ORANGE	80009	352-0168-03

<http://www.ebaman.com>

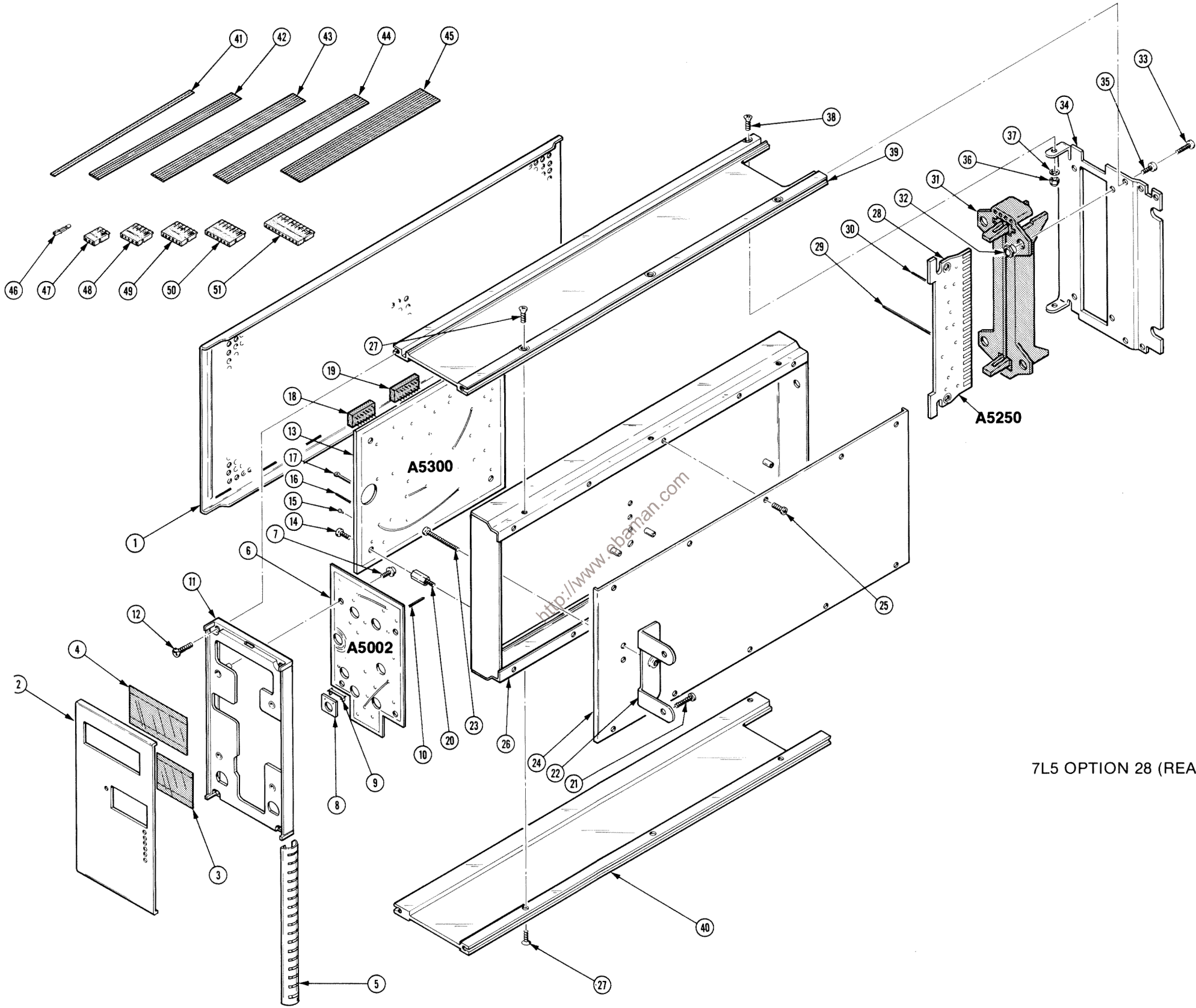

7L5 OPTION 28 (READOUT)

Fig. & Index No.	Tektronix Part No.	Serial/Model No.		Qty						Name & Description	Mfr Code	Mfr Part Number
		Eff	Dscont		1	2	3	4	5			
	070-2155-03			1						MANUAL, TECH: INSTRUCTION	80009	070-2155-03

<http://www.ebaman.com>

7L5 OPTION 30

Log Sweep and Track Generator

GENERAL INFORMATION

Introduction

The 7L5 Option 30 is a combination of Option 21 and Option 25. It provides the user with an IRIG logarithmic frequency span (250 Hz to 222 kHz) display as featured in Option 21, as well as a tracking generator which provides a 10 Hz to 5 MHz signal source that tracks the tuned input frequency of the spectrum analyzer, as is featured in Option 25.

<http://www.ebaman.com>

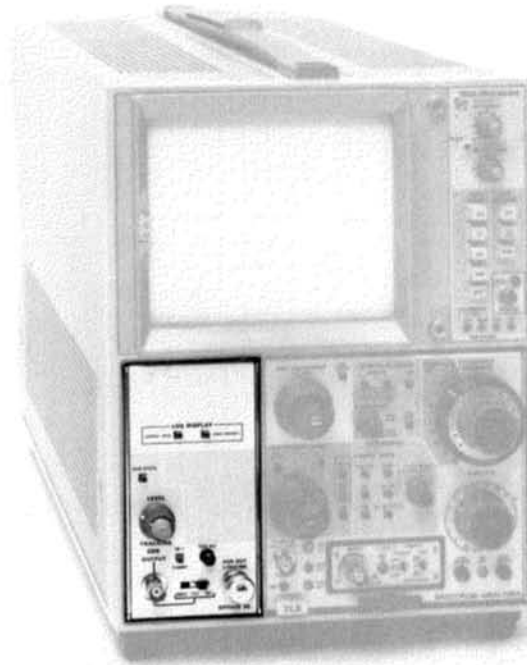

2155-26

Option 30 Fig. 1. 7L5 Option 30.

<http://www.ebaman.com>

DETAILED INFORMATION

The 7L5 Option 30 is a combination of Option 21 and Option 25. It provides the user with an IRIG logarithmic frequency span (250 Hz to 222 kHz) display as featured in Option 21, as well as a tracking generator which provides a 10 Hz to 5 MHz signal source that tracks the tuned input frequency of the spectrum analyzer, as is featured in Option 25.

For further specifics as to specifications, operating instructions, performance check, calibration procedure, circuit description, maintenance instructions, replaceable electrical parts, and replaceable mechanical parts, please refer to 7L5 Option 21 and Option 25, respectively.

The following are changes to the Replaceable Electrical Parts list, the Replaceable Mechanical Parts list, and the Accessories:

In the Replaceable Electrical Parts change to: A5001 and A5000 (Option 21 and Option 25 respectively), 670-4839-00 CKT BOARD ASSY: FRONT PANEL.

In the Replaceable Mechanical Parts change to: Fig. and Index No. 1-2 and 1-7 (Option 21 and Option 25 respectively), 333-2240-00 1 PANEL, FRONT.

In the Accessories change the manual part number to: 070-2155-03 1 MANUAL, TECH: INSTRUCTION.

MANUAL CHANGE INFORMATION

At Tektronix, we continually strive to keep up with latest electronic developments by adding circuit and component improvements to our instruments as soon as they are developed and tested.

Sometimes, due to printing and shipping requirements, we can't get these changes immediately into printed manuals. Hence, your manual may contain new change information on following pages.

A single change may affect several sections. Since the change information sheets are carried in the manual until all changes are permanently entered, some duplication may occur. If no such change pages appear following this page, your manual is correct as printed.

SERVICE NOTE

Because of the universal parts procurement problem, some electrical parts in your instrument may be different from those described in the Replaceable Electrical Parts List. The parts used will in no way alter or compromise the performance or reliability of this instrument. They are installed when necessary to ensure prompt delivery to the customer. Order replacement parts from the Replaceable Electrical Parts List.

CALIBRATION TEST EQUIPMENT REPLACEMENT

Calibration Test Equipment Chart

This chart compares TM 500 product performance to that of older Tektronix equipment. Only those characteristics where significant specification differences occur, are listed. In some cases the new instrument may not be a total functional replacement. Additional support instrumentation may be needed or a change in calibration procedure may be necessary.

Comparison of Main Characteristics

DM 501 replaces 7D13		
PG 501 replaces 107 108	PG 501 - Risetime less than 3.5 ns into 50 Ω. PG 501 - 5 V output pulse; 3.5 ns Risetime	107 - Risetime less than 3.0 ns into 50 Ω. 108 - 10 V output pulse 1 ns Risetime
PG 502 replaces 107 108 111	PG 502 - 5 V output PG 502 - Risetime less than 1 ns; 10 ns Pretrigger pulse delay	108 - 10 V output 111 - Risetime 0.5 ns; 30 to 250 ns Pretrigger pulse delay
PG 508 replaces 114 115 2101	Performance of replacement equipment is the same or better than equipment being replaced.	
PG 506 replaces 106 067-0502-01	PG 506 - Positive-going trigger output signal at least 1 V; High Amplitude output, 60 V. PG 506 - Does not have chopped feature.	106 - Positive and Negative-going trigger output signal, 50 ns and 1 V; High Amplitude output, 100 V. 0502-01 - Comparator output can be alternately chopped to a reference voltage.
SG 503 replaces 190, 190A, 190B 191 067-0532-01	SG 503 - Amplitude range 5 mV to 5.5 V p-p. SG 503 - Frequency range 250 kHz to 250 MHz.	190B - Amplitude range 40 mV to 10 V p-p. 0532-01 - Frequency range 65 MHz to 500 MHz.
SG 504 replaces 067-0532-01 067-0650-00	SG 504 - Frequency range 245 MHz to 1050 MHz.	0532-01 - Frequency range 65 MHz to 500 MHz.
TG 501 replaces 180, 180A 181 184 2901	TG 501 - Trigger output-slaved to marker output from 5 sec through 100 ns. One time-mark can be generated at a time. TG 501 - Trigger output-slaved to marker output from 5 sec through 100 ns. One time-mark can be generated at a time. TG 501 - Trigger output-slaved to marker output from 5 sec through 100 ns. One time-mark can be generated at a time.	180A - Trigger pulses 1, 10, 100 Hz; 1, 10, and 100 kHz. Multiple time-marks can be generated simultaneously. 181 - Multiple time-marks 184 - Separate trigger pulses of 1 and 0.1 sec; 10, 1, and 0.1 ms; 10 and 1 μs. 2901 - Separate trigger pulses, from 5 sec to 0.1 μs. Multiple time-marks can be generated simultaneously.

NOTE: All TM 500 generator outputs are short-proof. All TM 500 plug-in instruments require TM 500-Series Power Module.

DESCRIPTION

OPTION 25

ELECTRICAL PARTS LIST AND SCHEMATIC CHANGES

CHANGE TO:

VR5028 152-0693-00 SEMICOND DEVICE:ZENER,4.0V,5%,1MA,400MW

VR5028 is located on the DIGITAL circuit board assembly and shown on diagram 3 OUTPUT LEVEL AND IMPEDANCE CONTROL OPTION 25.

<http://www.ebaman.com>