

<http://www.ebaman.com>
TEKTRONIX®

7D13
DIGITAL
MULTIMETER

INSTRUCTION MANUAL

Tektronix, Inc.
P.O. Box 500
Beaverton, Oregon 97077

Serial Number _____

WARRANTY

All Tektronix instruments are warranted against defective materials and workmanship for one year.

Any questions with respect to the warranty, mentioned above, should be taken up with your Tektronix Field Engineer or representative.

All requests for repairs and replacement parts should be directed to the Tektronix Field Office or representative in your area. This procedure will assure you the fastest possible service. Please include the instrument Type (or Part Number) and Serial or Model Number with all requests for parts or service.

Specifications and price change privileges reserved.

Copyright © 1971 by Tektronix, Inc., Beaverton, Oregon. Printed in the United States of America. All rights reserved. Contents of this publication may not be reproduced in any form without permission of the copyright owner.

U.S.A. and foreign Tektronix products covered by U.S. and foreign patents and/or patents pending.

TABLE OF CONTENTS

	Page
SECTION 1 SPECIFICATION	
Introduction	1-1
Electrical Characteristics	1-1
Environmental Characteristics	1-2
Physical Characteristics	1-2
SECTION 2 OPERATING INSTRUCTIONS	
Installation	2-1
MODE/RANGE Control and Front Panel Connectors	2-1
First Time Operation	2-2
General Operating Instructions	2-4
SECTION 3 CIRCUIT DESCRIPTION	
Introduction	3-1
Block Diagram Description	3-1
Detailed Circuit Description	3-2
SECTION 4 MAINTENANCE	
Preventive Maintenance	4-1
Troubleshooting	4-1
Replacement Parts	4-4
Component Replacement	4-4
Recalibration After Repair	4-5
SECTION 5 CALIBRATION	
Introduction	5-1
Test Equipment Required	5-1
Part I—Performance Check	5-3
Part II—Adjustment	5-7
SECTION 6 ELECTRICAL PARTS LIST	
Abbreviations and Symbols	
Parts Ordering Information	
SECTION 7 DIAGRAMS AND CIRCUIT BOARD ILLUSTRATION	
Symbols and Reference Designators	
Voltage and Waveform Conditions	
SECTION 8 MECHANICAL PARTS LIST	
Mechanical Parts List Information	
Index of Mechanical Parts Illustrations	
Mechanical Parts List	
Accessories	

CHANGE INFORMATION

Abbreviations and symbols used in this manual are based on or taken directly from IEEE Standard 260 "Standard Symbols for Units", MIL-STD-12B and other standards of the electronics industry. Change information, if any, is located at the rear of this manual.



Fig. 1-1. 7D13 Digital Multimeter.

SECTION 1

SPECIFICATION

Change information, if any, affecting this section will be found at the rear of this manual.

Introduction

The 7D13 Digital Multimeter plug-in unit is designed for use with Tektronix 7000-series Oscilloscopes equipped with a readout system. The 7D13 can be used to measure DC voltage, DC current, resistance, and temperature.

Temperature measurements are made with the P6058 probe or a temperature-sensing device connected to the front-panel PROBE connector. An analog temperature signal output is available at the front-panel TEMP OUT

connectors regardless of the setting of the MODE/RANGE control.

The output of the 7D13 is presented as a digital readout on the CRT of the associated oscilloscope, along with information encoded by the other plug-in units. This display is written by the CRT beam on a time-shared basis with the analog waveform display from the other plug-in units.

The electrical characteristics listed in Table 1-1 are valid over the stated environmental range for instruments calibrated at an ambient temperature of +20°C to +30°C, and after a 20 minute warmup unless otherwise noted.

TABLE 1-1
ELECTRICAL CHARACTERISTICS

Characteristic	Performance Requirement	Supplemental Information
DC VOLTS		
Range	0 to 1000 volts	Four full-scale ranges of ± 2.000 V, ± 20.00 V, ± 200.0 V, and ± 1000 V.
Accuracy +15°C to +40°C	Within 0.1% of reading ± 1 count.	
0°C to +50°C	Within 0.2% of reading ± 2 counts.	
Polarity		Automatic selection and display.
Input Resistance		10 M Ω within 1% on all ranges.
Maximum Non-Destructive Input Voltage	1000 V peak between INPUT connectors. 1500 V peak between either connector and ground.	For Maximum Input Voltage rating for voltage measurements with voltage/temperature probe, see probe instruction manual.
DC CURRENT		
Range	0 to 2 Amperes	Four full-scale ranges of ± 2.000 mA, ± 20.00 mA, ± 200.0 mA, and ± 2000 mA.
Accuracy +15°C to +40°C	Within 0.5% of reading ± 2 counts.	
0°C to +50°C	Within 0.7% of reading ± 4 counts.	
Polarity		Automatic selection and display.

TABLE 1-1 (cont)

Characteristic	Performance Requirement	Supplemental Information
DC CURRENT (cont) Input Resistance		$\frac{0.2 \text{ V}}{\text{Full Scale Current}} + 0.3 \Omega$
Maximum Non-Destructive Input Current	3 Amperes	Limited by fuse and clamping diodes.
RESISTANCE Range	0 to 2 M Ω	Five full-scale ranges of 200.0 Ω , 2000 Ω , 20.00 k Ω , 200.0 k Ω , and 2000 k Ω .
Accuracy +15°C to +40°C	Within 0.5% of reading ± 1 count.	
0°C to +50°C	Within 0.8% of reading ± 2 counts.	
Overload Protection		Limited by 60 mA fuse.
Reference Current Magnitude (Amperes)		$\frac{2 \text{ V}}{\text{Full-Scale Resistance (ohms)}}$
TEMPERATURE Range	-55°C to +150°C in one range.	
Accuracy (with P6058 Probe) 7D13 Ambient Temperature Range +15°C to +40°C	Within 1°C to +125°C	Measurements above +125°C are subject to probe derating, see probe instruction manual.
0°C to +50°C	Within 2°C to +125°C	
TEMP OUT 10 mV/°C Accuracy	Within 10 mV	Load impedance must not be less than 2 k Ω .
Noise Rejection Normal Mode Rejection Ratio	At least 30 dB at 60 Hz increasing at 20 dB/decade.	
Common Mode Rejection Ratio (1 k Ω unbalance)	At least 100 dB at DC; 80 dB at 60 Hz.	
Recycle Time		200 milliseconds (5 measurements per second)
Settling Time		1.5 seconds or less.

TABLE 1-2

ENVIRONMENTAL CHARACTERISTIC

Refer to the Specification for the associated oscilloscope.

TABLE 1-3

PHYSICAL

Size	Fits all 7000-series plug-in compartments.
Weight	1 Pound 12 Ounces (797 grams)

SECTION 2

OPERATING INSTRUCTIONS

Change information, if any, affecting this section will be found at the rear of this manual.

General

The 7D13 Digital Multimeter unit operates with the readout system of a Tektronix 7000-series oscilloscope to provide the capability to measure DC voltage, DC current, resistance, and temperature. To effectively use the 7D13, the operation and capabilities of the instrument should be known. This section describes the operation of the front-panel controls, giving first-time and general operating information.

Installation

The 7D13 is designed to operate in any plug-in compartment of Tektronix 7000-series oscilloscopes. To install the 7D13 into a plug-in compartment, push it in until it is seated flush against the front panel of the oscilloscope. To remove, pull the release latch to disengage the 7D13 from the oscilloscope. Continue to pull the release latch to remove the unit from the oscilloscope.

Display

The output for the 7D13 Digital Multimeter is a digital readout display presented on the CRT of the oscilloscope in which the unit is operated, along with information encoded by the other plug-in units. This display is written by the CRT beam on a time-shared basis with the analog waveform display from the other plug-in units.

The digital readout display for the 7D13 will appear in the top division of the CRT in a location corresponding to the plug-in compartment used. There is no analog output signal presented on the CRT; therefore, it is not necessary to select the 7D13 with the oscilloscope Vertical or Horizontal Mode switches.

The display consists of three full digits plus one for over-ranging. The measurement units and decimal position in the display are determined by the MODE/RANGE switch setting. When the measurement range in use is exceeded, the display blinks to indicate over-ranging.

MODE/RANGE CONTROL AND FRONT PANEL CONNECTORS

Introduction

The MODE/RANGE control and all connectors required for operation of the 7D13 are located on the front panel of the unit (see Fig. 2-1). To make full use of the capabilities of this instrument, the operator should be familiar

with the function and use of the MODE/RANGE control and each connector. A brief description of these and their relationship to one another is given here. More detailed information relating to measurement applications is given under General Operating Instructions.

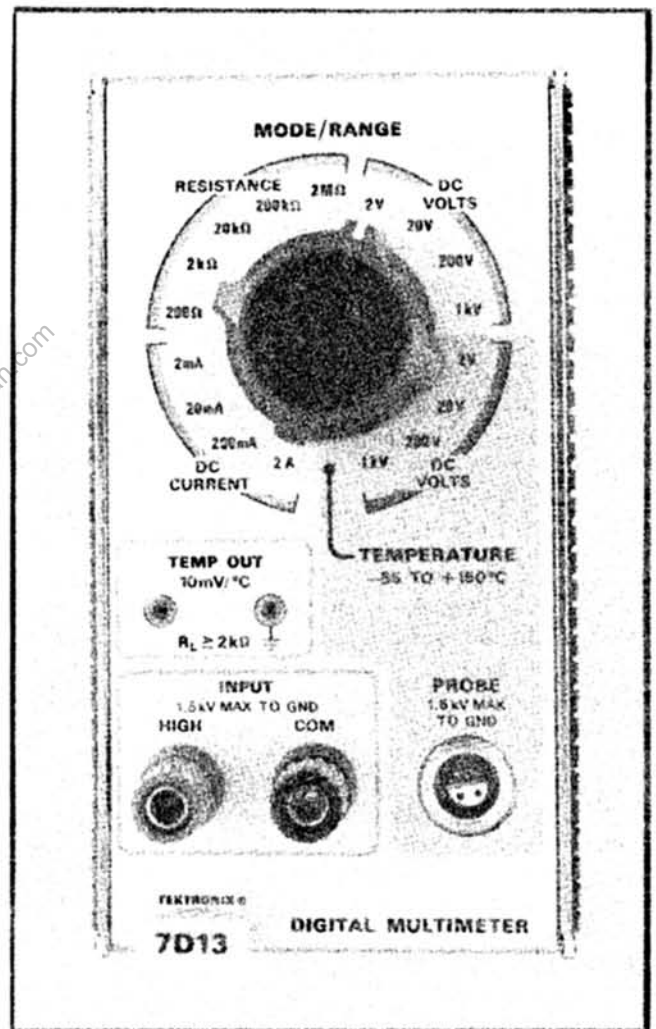

Fig. 2-1. MODE/RANGE control and Front-Panel connectors.

MODE/RANGE

Rotary Switch

Selects measurement mode and range simultaneously. Two sets of DC VOLTS ranges select measure-

Operating Instructions—7D13

ment via either the INPUT connectors or the PROBE connector. The selected input is indicated by front panel background tint.

INPUT	Binding posts labeled HIGH and COM provide connection of inputs for resistance, voltage, and current measurements. Both INPUT connectors can be floated above chassis (ground) potential (see Specification section).
TEMP OUT 10 mV/°C $R_L \geq 2 \text{ k}\Omega$	Pin jack connectors to provide an analog output of temperature measurement data from temperature measuring circuit. This data is provided regardless of the setting of the MODE/RANGE control.
PROBE	Four-pin, locking receptacle for attaching a voltage/temperature probe. Pins provide connection for probe power and signal input.

FIRST TIME OPERATION

General

When shipped from the factory, the 7D13 has been calibrated to meet the specifications listed in Section 1 and is ready to be used with a readout-equipped Tektronix 7000-series Oscilloscope.

Steps 1 through 21 of the following procedure provide an operational check to verify satisfactory operation of the unit and the associated oscilloscope. This portion of the procedure is intended as a quick functional check only and should be performed each time the 7D13 is placed in a different oscilloscope.

The remainder of the procedure demonstrates the basic operation of the MODE/RANGE control and the front-panel connectors. It is recommended that the entire procedure be followed completely for familiarization with the instrument. Operation of the oscilloscope is described in the oscilloscope instruction manual.

The tolerances given for the digital readout are for units being operated in an ambient temperature range of +15°C to +40°C. For operation outside of these limits, refer to Table 1-1 in the Specification section.

Preliminary Instructions

1. Install the 7D13 in any available plug-in compartment of a 7000-series oscilloscope.

2. Connect the oscilloscope to a power source which meets the frequency and voltage requirements of the oscilloscope power supply.

3. Turn the oscilloscope power on and allow about twenty minutes warmup time.

4. During the warmup period, set the controls as follows:

Oscilloscope

Intensity	Counterclockwise
Readout	Off

Any controls not mentioned can be set as desired.

7D13

MODE/RANGE	DC VOLTS/1 kV (INPUT connectors)
------------	-------------------------------------

Digital Display Check

5. Connect the 7D13 INPUT connectors together with a short piece of wire.

6. Advance the oscilloscope Readout control to obtain a usable digital display on the CRT. The display should appear in the upper graticule division.

7. The readout should read 000 V plus or minus one count (−001 V to +001 V).

8. Set the MODE/RANGE control to DC CURRENT/2 mA.

9. The readout should read .000 mA plus or minus two counts (+.002 mA to −.002 mA).

10. Set the MODE/RANGE control to RESISTANCE/200 Ω .

11. The readout should read within the limits of 00.0 Ω to 00.1 Ω (no polarity indicator).

12. Set the MODE/RANGE control to RESISTANCE/2 k Ω .

13. The readout should be within the limits of 000 Ω to 001 Ω .

14. Set the MODE/RANGE control to RESISTANCE/20 k Ω .

15. The readout should be within the limits of 0.00 k Ω to 0.01 k Ω .

16. Set the MODE/RANGE control to RESISTANCE/200 k Ω .

17. The readout should be within the limits of 00.0 k Ω to 00.1 k Ω .

18. Set the MODE/RANGE control to RESISTANCE/2 M Ω .

19. The readout should be within the limits of 000 k Ω to 001 k Ω .

20. Remove the piece of wire connecting the INPUT connectors together.

21. The readout display (7D13 only) will be blinking and will indicate a high value of resistance. The unit is attempting to measure the resistance between the INPUT connectors. Since this value exceeds the 2 M Ω range, the display blinks to indicate over-ranging.

This concludes the operational check procedure.

Resistance

22. Connect a pair of test leads to the INPUT connectors.

23. Connect a 10 k Ω resistor between the test leads. (The value of the resistor is not critical for the purposes of this demonstration.)

24. The readout display will read the value of the resistor used. Set the MODE/RANGE switch to RESISTANCE/200 k Ω and RESISTANCE/20 k Ω and notice that the reading changes to include more significant figures.

25. Set the MODE/RANGE control to RESISTANCE/2 k Ω and observe that the display blinks to indicate over-ranging.

DC Current

26. Disconnect the COM test lead from the resistor and connect it to the oscilloscope ground post.

27. Set the oscilloscope Calibrator to 4 V and the Rate (Calibrator) switch to DC.

28. Set the MODE/RANGE switch to DC CURRENT/2 mA.

29. With the HIGH test lead still attached to the resistor, touch the other end of the resistor to the oscilloscope Cal output connector.

30. The readout will indicate a current of approximately +.4__ mA.

Voltage

31. Remove the resistor from the Cal connector and disconnect it from the HI test lead.

32. Set the MODE/RANGE switch to DC VOLTS/20 V.

33. Touch the HIGH test lead to the oscilloscope Cal connector.

34. The readout will read about +4.00 V (the exact reading will depend upon the calibration of the oscilloscope calibrator).

35. Reverse the test lead connections; i.e., connect the HIGH test lead to the ground post and the COM test lead to the Cal connector.

36. The readout should read the same value of voltage as in step 34 but with a – polarity indicated.

Temperature

37. Connect a voltage/temperature probe such as the P6058 to the 7D13 PROBE connector. Observe the precautions relating to proper alignment of the connectors as given in the Probe instruction manual.

38. Set the MODE/RANGE control to TEMPERATURE.

Operating Instructions—7D13

39. The readout should read the room temperature within the limits listed in Table 1-1 of Section 1. (Alternate Procedure: Place the probe in an environment having a known temperature.)

40. Connect the INPUT connectors to the TEMP OUT pin jack connectors with the test leads. The COM connector should be connected to the right hand TEMP OUT connector (ground).

41. Set the MODE/RANGE control to DC VOLTS/2 V.

42. The readout display will read out a voltage corresponding to 10 mV per each degree Centigrade of the temperature reading obtained in step 39 within 0.1%. For example, if the reading obtained in step 23 was +25°C, the reading obtained in this step should be 10 mV X +25 equals 250 mV or +.250 V.

43. Disconnect the test leads and the voltage/temperature probe. This completes the First Time Operation Procedure.

GENERAL OPERATING INSTRUCTIONS

Resistance Measurements

The 7D13 measures resistance in five full-scale ranges as follows: 00.0 to 200.0 Ω ; 000 to 2000 Ω ; 0.00 k to 20.00 k Ω ; 00.0 k to 200.0 k Ω ; and 000 k to 2000 k Ω . To operate the 7D13 as an ohmmeter, proceed as follows:

1. Install the 7D13 in any available plug-in compartment of a Tektronix 7000-series Oscilloscope.

2. Turn the oscilloscope power on. Allow twenty minutes warmup.

3. Advance the oscilloscope Readout control to obtain a usable readout display (if necessary, refer to the oscilloscope instruction manual).

4. Set the MODE/RANGE control to the desired RESISTANCE range.

5. Connect the INPUT connectors to the resistance to be measured.

DC Voltage Measurements

The 7D13 can measure DC voltages up to 1 kV in four full-scale ranges as follows: ± 0.000 to ± 2.000 V; ± 0.00 to ± 20.00 V; ± 00.0 to ± 200.0 V; and ± 000 to ± 1000 V.

The voltage to be measured can be connected to the 7D13 via the INPUT connectors or a compatible probe connected to the PROBE connector. Observe the Maximum Safe Input Voltage limits given in Table 1-1 in the Specification section for all measurements.

To measure DC voltages via the INPUT connectors, use the following procedure:

1. Install the 7D13 in any available plug-in compartment of a Tektronix 7000-series Oscilloscope.

2. Turn the oscilloscope power on. Allow about twenty minutes warmup.

3. Advance the oscilloscope Readout control to obtain a usable readout display (if necessary, refer to the oscilloscope instruction manual).

4. Select the desired full-scale voltage range with the MODE/RANGE switch. (The ranges to be used with measurements made via the INPUT connectors are indicated by the orange tint of the front panel.)

5. Connect the voltage to be measured to the INPUT connectors. The readout will display a "+" preceding the reading if the HIGH input terminal is positive with respect to the COM terminal, and "-" if the HIGH terminal is negative with respect to the COM terminal.

To measure DC voltages with the probe, use the following procedure:

1. Install the 7D13 in any available plug-in compartment of a Tektronix 7000-series Oscilloscope.

2. Turn the oscilloscope power on. Allow about twenty minutes warmup.

3. Advance the oscilloscope Readout control to obtain a usable readout display (refer to the oscilloscope instruction manual if necessary).

4. Select the desired full-scale voltage range by setting the MODE/RANGE control to one of the four DC VOLTS ranges with the gray front-panel background.

5. Connect a compatible probe to the front-panel PROBE connector.

CAUTION

When connecting the probe to the PROBE connector, the two connectors must be correctly aligned. Damage to the terminals can result from forcing the connector and jack together. Refer to the probe instruction manual.

6. Apply the voltage to be measured between the probe tip and the common strap on the probe. Do not use the COM INPUT connector when making a measurement with the probe.

7. The readout will display a "+" preceding the voltage reading if the probe tip is positive with respect to the common strap, and "-" if the probe tip is negative with respect to the common strap.

Voltage measurements with the probe are essentially the same as with test leads. The probe is a straight-through device; i.e., it provides no attenuation to extend the measurement range. The probe is shielded to minimize pickup of electrostatic interference. (For more information, see the instruction manual for the probe.)

DC Current Measurements

The 7D13 will measure DC current in four ranges, as follows: .000 to 2.000 mA; 0.00 to 20.00 mA; 00.0 to 200.0 mA; and 000 to 2000 mA.

To measure DC current with the 7D13, use the following procedure:

1. Install the 7D13 in any available plug-in compartment of a Tektronix 7000-series oscilloscope.

2. Turn the oscilloscope power on. Allow about twenty minutes warmup.

3. Advance the oscilloscope Readout control to obtain a usable readout display (if necessary, refer to the oscilloscope instruction manual).

4. Set the MODE/RANGE switch to the desired full-scale DC CURRENT range.

5. Connect the DC current to be measured to the INPUT connectors.

The polarity of the current is sensed by the 7D13 circuitry and automatically displayed. The polarity symbol

displayed is dependent upon the relative voltage of the two INPUT connectors. If the HIGH input connector is positive with respect to the COM input connector, a "+" will be displayed and vice versa. For current measurements, a current (electron flow) into the COM connector and out of the HIGH connector will result in a "+" being displayed.

Temperature Measurements

The 7D13, in conjunction with a temperature sensing probe such as the P6058, can measure temperatures from -55°C to $+150^{\circ}\text{C}$ in one range.

To measure temperature, use the following procedure:

1. Install the 7D13 in any available plug-in compartment of a Tektronix 7000-series oscilloscope.

2. Turn the oscilloscope power on. Allow twenty minutes warmup.

3. Advance the oscilloscope Readout control to obtain a usable readout display (if necessary, refer to the oscilloscope instruction manual).

4. Connect the temperature-sensing probe to the front-panel PROBE connector.

CAUTION

When connecting the temperature probe to the PROBE connector, the two connectors must be correctly aligned. Damage to the terminals can result from forcing the connector and jack together. Refer to the probe instruction manual.

5. Set the MODE/RANGE switch to TEMPERATURE.

6. Apply the probe sensor tip to the device being measured. For optimum temperature transfer, the surface of the device being measured should be coated with silicon grease and the probe tip should be applied squarely to the surface.

7. Allow a sufficient amount of time for the probe tip to "settle" before taking a reading. The time required depends upon several factors. Generally, when the tip is first applied to the device under test, the readings will change rapidly. As the probe tip temperature approaches the temperature of the device under test, the reading will stabilize or "settle".

Using a Transistor as a Temperature-Sensing Device

Certain NPN transistors such as a 2N2484 can be used as a separate sensor in place of the probe tip with little or no selection of the device.

Operating Instructions—7D13

Typical accuracy, without recalibration of the 7D13, can be expected to be within 1°C for measurements from -55°C to $+125^{\circ}\text{C}$. However, device parameters could vary, causing inaccuracies in the temperature readout as great as $\pm 5^{\circ}\text{C}$.

If the measurement to be made requires an accuracy greater than $\pm 5^{\circ}\text{C}$, the calibration should be checked. Check the calibration by placing the sensing device in an environment having a known ambient temperature, and comparing the readout versus known temperature. Any difference noted at the test temperature can be used as a correction factor throughout the measurement range of -55°C to $+125^{\circ}\text{C}$.

The temperature-sensing transistor is connected to the 7D13 through the front-panel PROBE connector using two-conductor shielded cable and a connector plug (Tektronix Part Number 131-0778-00). A wiring diagram is shown in Fig. 2-2.

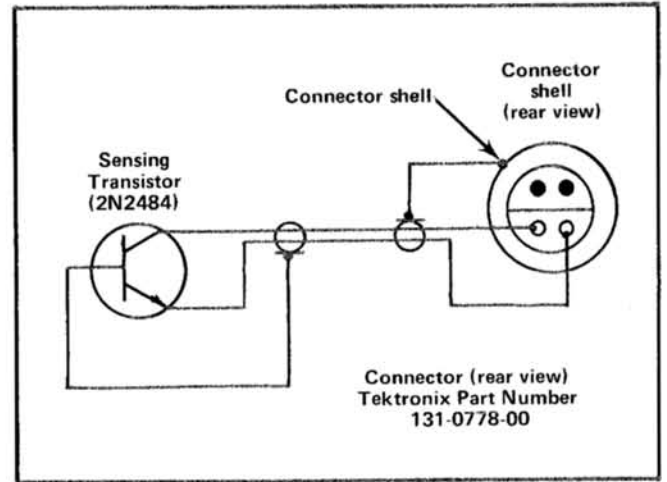

Fig. 2-2. Schematic diagram of temperature-sensing transistor connected to probe connector.

<http://www.ebaman.com>

SECTION 3

CIRCUIT DESCRIPTION

Change information, if any, affecting this section will be found at the rear of this manual.

Introduction

This section of the manual contains a description of the circuitry used in the 7D13 Digital Multimeter Plug-In. The description begins with a discussion of the the instrument using the Block Diagram given in the Diagrams section. Following the block diagram description is a more detailed description, particularly for circuits unique to this instrument. If more information is desired on commonly used circuits, refer to the following textbooks:

Tektronix Circuit Concepts Books (order from your local Tektronix Field Office or representative):

Digital Concepts, Tektronix Part No. 062-1030-00.

Power Supply Circuits, Tektronix Part No. 062-0888-01.

Jacob Millman and Herbert Taub, "Pulse, Digital, and Switching Waveforms", McGraw-Hill, New York, 1965.

Digital logic techniques are used to perform many functions within this instrument. The function and operation of the logic circuits are described using logic symbology and terminology. For further information, see Logic Fundamentals in Section 3 of the oscilloscope instruction manual.

Following the detailed circuit description is a brief discussion of the readout system used in Tektronix 7000-series Oscilloscopes. If more information is desired on the readout system, refer to the instruction manual for the oscilloscope.

NOTE

All references to direction of current in this manual are in terms of conventional current; i.e., from plus to minus.

BLOCK DIAGRAM DESCRIPTION

The heavy dashed line on the Block Diagram encloses the measurement input circuits. These circuits are isolated from the remainder of the 7D13 circuits to allow them to follow a common-mode voltage up to 1500 volts. The input

circuit isolation is accomplished by transformer coupling of signals and by the Floating Power Supply.

The Attenuator and Switching circuit selects and attenuates, when necessary, inputs to be measured from the INPUT connectors, PROBE connector, Ohms Converter, and Temperature Measurement circuits. A positive or negative output voltage is provided to the $|G_m|$ Converter which is within the limits of the Floating Power Supply.

The $|G_m|$ Converter converts the positive or negative input voltage to a single-polarity current output for the Analog-to-Pulse-Width Converter. The $|G_m|$ Converter also provides an output indicating the relative polarity of the input voltage to the Polarity Indicator circuit.

When the MODE/RANGE switch is set to RESISTANCE, the Ohms Converter measures resistance connected between the INPUT connectors. The output provided to the $|G_m|$ Converter is a voltage proportional to the resistance being measured.

The Analog-to-Pulse-Width Converter measures the single-polarity current from the $|G_m|$ Converter. The Analog-to-Pulse-Width Converter is clocked by the Last Count pulse from the Counter to provide an output $\overline{\text{STORE COMMAND}}$ pulse to the Memory circuit. The time relationship between this output pulse and the Last Count is a direct function of the analog input current from the $|G_m|$ Converter.

The Polarity Indicator circuit provides an output to the Readout Logic to indicate the relative polarity of the input voltage.

The Clock generates an 80 kilohertz clock signal. The 80 kilohertz signal is counted down by the $\div 2$ stage to provide a 40 kilohertz signal which is counted by the Counter circuit, and which is used to trigger the Floating Power Supply.

The Counter circuit continually counts the 40 kilohertz signal from the Clock. The Counter output to the Memory circuit is in a 1-2-4-8 binary-coded-decimal (BCD) form.

Circuit Description—7D13

Other Counter outputs are a two kilohertz trigger to the Temperature Measurement circuit, and a Last Count pulse to the Analog-to-Pulse-Width Converter and Readout Logic circuits. The Last Count indicates that the Counter is full (has counted to 8000).

The Memory circuit reads the 1-2-4-8 BCD output from the Counter on command of the Analog-to-Pulse-Width Converter STORE COMMAND output. Time-slot data from the Readout Logic circuit enables the Memory to provide a BCD output having the proper time relationship to drive the Readout Logic.

The Readout Logic receives the BCD input from the Memory circuit and encodes data so the oscilloscope readout system can display a digital readout of the measurement.

The Temperature Measurement circuit provides an output voltage which varies directly with the temperature of a temperature-sensing transistor (connected to the Temperature Measurement circuit via the front-panel PROBE connector). The output voltage can be selected by the MODE/RANGE switch to be measured and displayed as a temperature readout. The output voltage is also available at the front-panel TEMP OUT connectors for any setting of the MODE/RANGE switch.

INPUT SWITCHING AND OHMS CONVERTER

Input Switching

General. The Input Switching circuit consists of the input sections of the MODE/RANGE switch, attenuator resistors, and input-protection components. (Other sections of the MODE/RANGE switch encode the readout logic which is described under Readout Logic.)

The Input Switching circuit selects and attenuates, when necessary, a measurement input to provide an output voltage to the $|G_m|$ Converter circuit. The output voltage, V_x , appears across the points labeled V_x and DVM Low. The output voltage should not exceed the maximum input voltage limits of the $|G_m|$ Converter (limited by the Floating Power Supply to plus or minus 15 volts). Thus, attenuation of the measurement input is necessary when it would otherwise exceed these limits.

The Temperature Measurement circuit and the Ohms Converter have outputs which are within the maximum input voltage limits of the $|G_m|$ Converter. Thus, when either of these outputs is selected by the MODE/RANGE switch, it is connected directly to the $|G_m|$ Converter without attenuation.

DC Volts. When the MODE/RANGE switch is set to any of the DC VOLTS ranges, it connects the INPUT connectors (or the high and low terminals of the PROBE connector) across R60. R60 is a precision, tapped, 10 megohm resistor which is used as an input resistor/voltage divider for the DC VOLTS mode. Thus, the voltage being measured is applied across the full 10 megohm resistance of R60 while the V_x output is taken from the appropriate tap for each full-scale DC VOLTS range.

DC Current. When the MODE/RANGE switch is set to a DC CURRENT range, one or more sections of R10 or R60 is connected as a shunt across the INPUT connectors. The voltage drop resulting from a measured DC current through the selected shunt resistance provides the V_x output to the $|G_m|$ Converter.

Fuse F6, in series with the shunt resistance, protects R10 and R60 from damage due to excessive input current. Rectifier diodes CR7-CR8 protect R10 and R60 from damage due to excessive input voltage.

Ohms Converter. This circuit is made up of constant-current source Q39 and U45, operational amplifier U32, high-impedance input Q24, and constant-current source Q28. A simplified diagram of the Ohms Converter circuit is shown in Fig. 3-1.

The constant-current source consisting of Q39 and U45 supplies a constant current through R36 to the output of U32 at pin 6. VR47 sets the voltage at the plus input of U45. The output of U45 at pin 6 is fed back to the minus input through the gate-source junction of Q39 to obtain a null voltage. Thus, the voltage at the junction of the source of Q39 and R40 will be the same as the voltage set by VR47. Since the voltage across R40, R42, and R44 is held constant by U45-Q39, the current through them is adjustable by R44, Ohms Adjustment.

Q24 effectively inverts the inputs to U32. Thus pin 3-Q24 becomes the plus input to the operational amplifier and pin 7-Q24 becomes the minus input. In the RESISTANCE ranges, R60 provides feedback from the output of U32 to the plus input (pin 3-Q24). The operation of U32-Q24 is such that it produces a null voltage at the plus input (pin 3-Q24) which is equal to the voltage established at the minus input (pin 7-Q24). The constant current through R36 from U45-Q39 establishes a fixed voltage between the output of U32 and the minus input (pin 7-Q24) in all RESISTANCE ranges. Therefore, the voltage drop required across R60 to produce a null is also fixed.

As the MODE/RANGES switch is set to the various RESISTANCE RANGES, different sections of R60 are

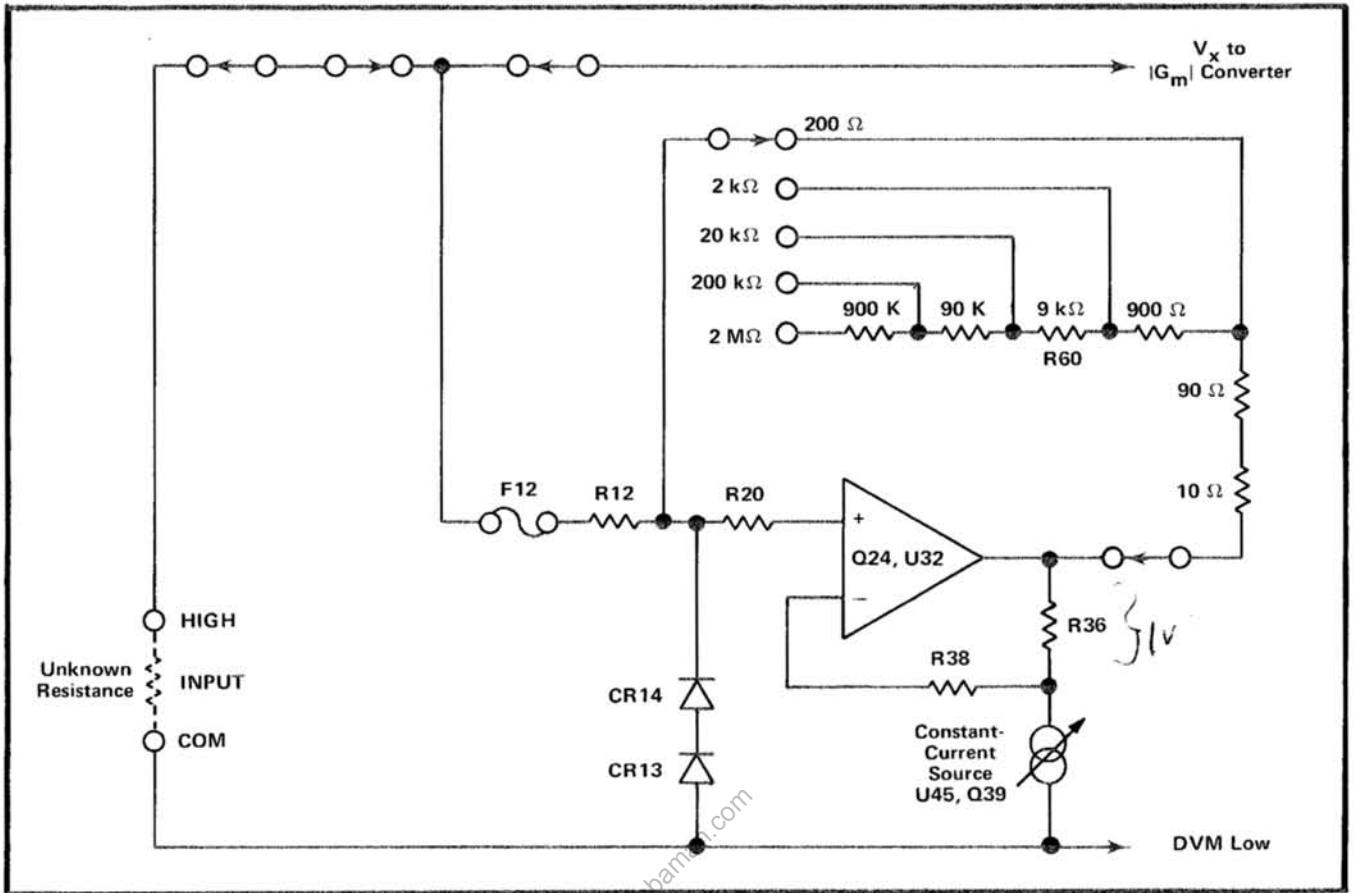

Fig. 3-1. Simplified diagram of the Ohms Converter circuit.

connected into the circuit. Since the voltage drop necessary across R60 to establish a null at the plus input (pin 3-Q24) is constant for all RESISTANCE ranges, the current through R60 must change as the resistance of R60 is effectively increased or decreased. However, once the RESISTANCE range is selected, the current through the selected section(s) of R60 is held constant by U32-Q24. This constant current is available at the HIGH INPUT connector through R12 and F12 to produce a voltage drop across an unknown resistance connected between the INPUT connectors. The resultant voltage drop across the unknown resistance produces an output at the V_X connector which is measured by the voltmeter circuits and read out as a resistance value.

$|G_m|$ CONVERTER AND ANALOG-TO-PULSE-WIDTH CONVERTER

General

The $|G_m|$ Converter and Analog-to-Pulse-Width Converter circuits measure input voltage V_X with respect to DVM Low from the Input Switching circuit and generate an output signal, STORE COMMAND, to the Store Command

Delay stage of the Memory circuit (diagram 3). Also, an output signal, MINUS, is provided to the Readout Logic to indicate that V_X is negative with respect to DVM Low; therefore, a minus (-) symbol should be displayed.

The $|G_m|$ Converter and Analog-to-Pulse-Width Converter circuits, along with the Ohms Converter, are powered from the Floating Power Supply to allow them to follow a common-mode voltage up to 1500 volts. Signals between the floating circuits and other circuits in the 7D13 are transformer-coupled for DC isolation.

$|G_m|$ Converter

The $|G_m|$ Converter consists of Q103, Q105, Q108, Q125, Q135, Q141, U118, and U128. This circuit provides a single-polarity current output to be integrated by the Integrator stage. The level of this current is determined by the absolute value of V_X with respect to DVM Low. Also, an output to Q173 in the Polarity Indicator circuit indicates the polarity of V_X with respect to DVM Low.

Circuit Description—7D13

The output signal is a current into the $|G_m|$ Converter from the Integrator current-summing point (at the gate of Q152). U118 or U128 "sink" the signal through CR142 as determined by the polarity of V_x . Field-effect diode CR142 limits the maximum signal current amplitude.

Q103 provides a high-impedance input to U118 for V_x . Because Q103 inverts the inputs to U118, pin 3 (gate) becomes the plus input to U118 and pin 7 becomes the minus input. Constant-current sources Q105-Q113, in conjunction with bootstrap emitter-follower Q108, maintain the parameters of Q103 constant over a wide range of operating conditions. CR101-CR102 limit the maximum value of V_x by conducting if V_x to DVM Low exceeds about plus or minus 15 volts (referenced to floating ground). R115, Zero Adjustment, provides an adjustment to balance the quiescent current through the two halves of Q103.

The voltage level at the output of U118 (pin 6) follows the voltage level at the plus input (pin 3-Q103). The output is fed back to the minus input (pin 7-Q103) to obtain a null; the feedback path is determined by the polarity of V_x .

The voltage level at the output of U128 (pin 6) follows the level at the gate of Q125 when V_x is negative with respect to DVM Low. For zero or positive levels of V_x , however, the output of U118 is negative.

The operational amplifier (U118 or U128), with the negative voltage level output becomes the output signal current sink. Assuming a negative value of V_x with respect to DVM Low, pin 6-U118 will be negative to forward bias CR119. CR119 becomes the feedback path between the output and the minus input of U118. VR139 keeps the gate of Q141 more negative than the source, to pinch off current through Q141. The signal current, therefore, flows through Q135 (drain to source), R124, R122, and CR119 to pin 6 of U118.

The circuit operation for positive levels of V_x is similar to that for negative levels. In this case, Q135 is pinched off and the signal current path is through Q141, R122, R124, and CR130 to pin 6 of U128.

Analog-to-Pulse-Width Converter

Integrator. The Integrator circuit, made up of Q152 and U155, generates a ramp output. The ramp amplitude and slope are functions of the current into or out of the current-summing point at the gate of Q152. The positive-going portion of the ramp charges with the current going to the $|G_m|$ Converter. The ramp will go positive until reset by the reference current being switched into the current-summing point. The voltage level reached by the positive ramp is

determined by the amount of current demanded by the $|G_m|$ Converter. The slope of the negative portion of the ramp is determined by the difference between the reference current and the current into the $|G_m|$ Converter.

Fig. 3-2 shows the time relationship of the Counter output and the Analog-to-Pulse-Width Converter circuits. The Integrator ramp waveform represents the Integrator output for a full-scale measurement (e.g., 2,000 V). Regardless of the measurement input, the duration of the ramp remains the same; the positive portion of the ramp always ends at T_0 , corresponding to the Last Count from the Counter.

Zero-Crossing Comparator. The Zero-Crossing Comparator, U158, generates a negative-going pulse when the negative-going ramp at its input reaches the zero-volt level (referenced to floating ground). The relationship between

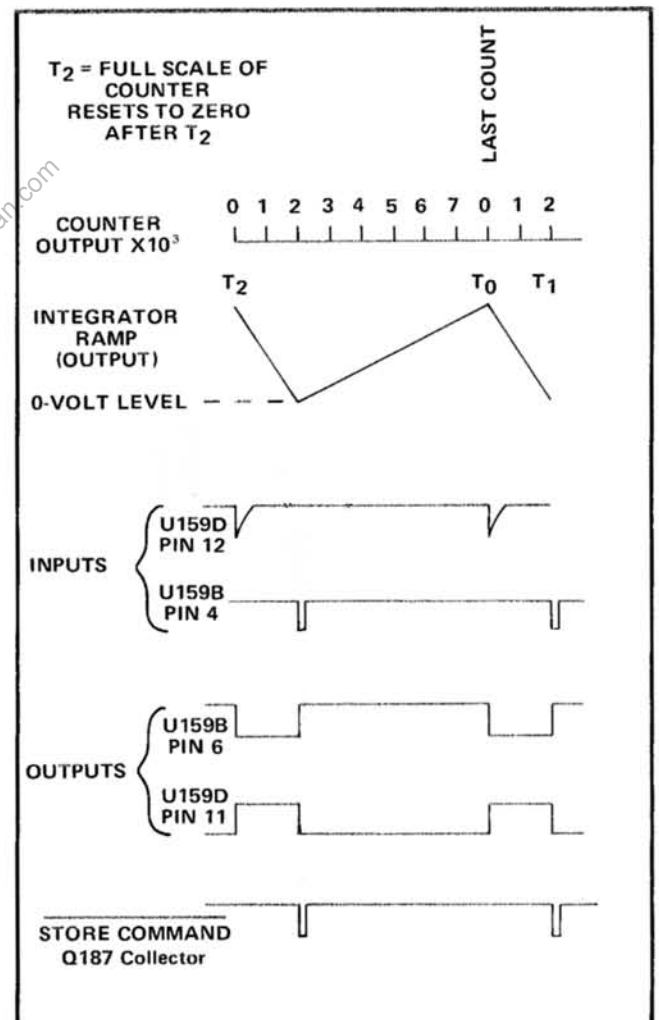

Fig. 3-2. Analog-to-Pulse-Width Converter circuit waveforms showing their relationship to the Counter output.

the ramp and the output of the Zero-crossing Comparator is shown in Fig. 3-2; the input to U159B at pin 4 is the output of the Zero-Crossing Comparator.

Zero-Crossing Flip-Flop. The Zero-Crossing Flip-Flop is an RS flip-flop made up of U159B and D. This circuit has two inputs and two complementary outputs, all of which are shown in Fig. 3-2.

One input to the flip-flop at pin 12-U159D is a negative-going pulse derived from the LAST COUNT from the Counter through T168 and Q169. The other input at pin 4-U159B is the negative-going pulse from the Zero-Crossing Comparator. The output pulses from the flip-flop are initiated by the Last Count input and terminated by the Zero-Crossing input.

The output from pin 6-U159B (negative-going pulse) is connected to the Reference Current Source to switch the reference current into the Integrator current-summing point. The output from pin 11-U159D (positive-going pulse) is connected to the Polarity Indicator circuit and to Q187 via C184 and T185.

The resulting signal at the collector of Q187 is a negative pulse, $\overline{\text{STORE COMMAND}}$, coincident with the Zero Crossing input to U159D (see Fig. 3-2). This signal is connected to the Store Command Delay circuit and to the Polarity Indicator circuit.

Reference Current Source. The Reference Current Source, consisting of U145, Q149, and Q163 supplies a constant current called the reference current, I_r . VR144 and U145 establish a constant voltage at the source of Q149. R148, Gain Adjustment, then provides adjustment of I_r through R148, R149, and Q149.

I_r is sunk from the drain of Q149 to the Floating Power Supply common through CR165, VR164, and Q163 when pin 6-U159B is HI. When the Last Count pulse sets pin 6-U159B to LO, Q163 is turned off to reverse bias CR165. I_r is now switched through CR150 to the Integrator current-summing point to end the positive portion of the ramp (see Fig. 3-2).

Polarity Indicator. The Polarity Indicator circuit consisting of Q173, U159A, U159C, Q182, and U189A provides the $\overline{\text{MINUS}}$ signal to the Readout Logic circuit. $\overline{\text{MINUS}}$, when at the LO level, indicates that the polarity symbol in the readout display should be a minus (−) symbol. $\overline{\text{MINUS}}$ is at the LO level when the relative polarity of V_x is negative with respect to DVM Low.

The output of U118-pin 6 in the $|G_m|$ Converter follows V_x (see $|G_m|$ Converter). When V_x is positive, the base of Q173 is positive. This results in Q173 being saturated. Thus, the collector of Q173 is at its LO level to inhibit U159A.

When V_x is negative with respect to DVM Low, Q173 is reverse biased by the LO level at its base. The resulting HI level at the collector of Q173 enables U159A. U159A will have an output each time the input from pin 11-U159D goes HI. The output of U159A is connected to U189A through U159C, T179, and Q182 to set the output of U189A, $\overline{\text{MINUS}}$, to a LO level.

CLOCK, COUNTER, AND MEMORY

Clock

The Clock consists of a collector-coupled astable multivibrator, Q200 and Q206, and a divide by two counter, U208B.

The multivibrator generates an 80 kilohertz clock signal. The 80 kilohertz signal is divided by two by U208B to provide a 40 kilohertz clock signal. The 40 kilohertz signal is connected to the Counter circuit, the Store Command Delay stage of the Memory circuit and the Floating Power Supply. R203, Clock, provides adjustment of the 80 kilohertz frequency.

Counter

The Counter circuit consists of divide by 10 counters, U210, U212, and U214, and a divide by eight counter, U208A. The Counter counts the 40 kilohertz clock signal to provide binary-coded-decimal outputs to the Memory.

The 2 kilohertz pulse from U212 is connected to the Temperature Measurement circuit for switching. Also, the positive LAST COUNT output from U208A is connected to the Analog-to-Pulse-Width Converter to indicate a full count; and to the Readout Logic to clock the Over-Range Indicator.

Memory

The Memory circuit includes the Storage Registers, Store Command Delay, and the Multiplexers.

Storage Registers. The Storage Registers consist of U218, U220, U222, and U224. The Storage Registers transfer the binary-coded-decimal Counter output to the Multiplexers when strobed by the STORE COMMAND signal from the Store Command Delay stage. Thus, only the

Circuit Description—7D13

Counter output up to the time of the STORE COMMAND signal is transferred to the Multiplexers and Readout Logic, while the count made after the STORE COMMAND is not passed on.

The Storage Register outputs to the Multiplexers are inverted in order to drive the Digital-to-Analog Converter in the Readout Logic, a negative-input device.

The $\overline{1000}$ output from pin 9-U224, is provided to the Readout Logic to indicate a measurement of 1000 or more. $\overline{1000}$ is LO for counts of 1000 or more. The $\overline{2000}$ output from pin 6-U224 is provided to the Readout Logic to indicate a count of 2000 or more. $\overline{2000}$ is LO only for counts of 2000 and greater, which enables the Over-Range Indicator circuit.

Store Command Delay. The Store Command Delay stage consists of Q190, U189B, U195A, U195B, U195C, U195D, and Q216.

The Store Command Delay stage receives the $\overline{\text{STORE COMMAND}}$ signal from the Analog-to-Pulse-Width Converter and provides the STORE COMMAND to the Storage Registers. The STORE COMMAND signal is slightly delayed by this stage if the $\overline{\text{STORE COMMAND}}$ input occurs at the same time that the 40 kilohertz Clock signal is triggering the Counter. Otherwise, an erratic or erroneous count would be displayed.

Multiplexer. The Multiplexer circuit consists of U260 and U262. The Multiplexers read the 1-2-4-8 outputs from the Storage Registers, translating only four specific bits at any one time. The time for each character is determined by the time-slot data from the Readout Logic circuit driving the Multiplexer address inputs. The Multiplexer output to the Digital-to-Analog Converter in the Readout Logic is a time-slot related 1-2-4-8 binary code.

READOUT LOGIC

General

The Readout Logic circuit encodes the Indicator Oscilloscope readout system to display the measurement made by the 7D13. The Readout Logic circuit also encodes the readout system to display the appropriate measurement units and polarity symbols, along with positioning the display decimal point and indicating an over-range measurement.

A discussion entitled Introduction to the Readout System following the 7D13 Circuit Description gives a brief description of the readout system used in Tektronix 7000-series Oscilloscopes.

Encoding Format

The 7D13 Readout Logic circuit encodes the Row and Column output lines (pins B37 and A37 respectively of the Interface Connector) according to the format given in Table 3-1. The time-slot pulses from the oscilloscope readout system are provided to the Readout Logic circuit through the Interface Connector. Several of the time-slot pulses are also connected to the Memory circuit to address the Multiplexers.

TABLE 3-1
7D13 READOUT FORMAT

TIME-SLOT NUMBER	DESCRIPTION
TS-1	Determines decimal position. Also, encodes a JUMP instruction to indicate over-ranging.
TS-2	Not used
TS-3	Indicates polarity of measurement.
TS-4	Most significant digit of measurement readout.
TS-5, TS-6 TS-7	Remaining three digits of measurement readout.
TS-8	Encodes m (milli-) and k (kilo-) prefixes, V (volts) and C (Celsius) measurement units.
TS-9	Encodes A (amperes) and Ω (ohms) measurement units.
TS-10	Not used

Digital-to-Analog Converter

The Digital-to-Analog Converter circuit includes D-A Converter, U264, and time-slot driver, Q259.

Time-slot pulses TS-4, TS-5, TS-6, and TS-7 from the Interface Connector are connected to the base of Q259 via diodes. Q259 then drives the $\overline{\text{ENABLE}}$ input of U264 at pin 8.

The $\overline{\text{INPUTS}}$ to U264 at pins 2, 3, 4, and 5 receive the 1-2-4-8 binary code from the Multiplexers. U264 then encodes the Column Current output at pin 15 according to the binary weight of each number; the position of each figure is determined by the time-slot pulses (see Table 3-1).

MODE/RANGE Switch

The MODE/RANGE switch encodes the readout system by switching resistors between the appropriate time-slot inputs and the Column and/or Row Current output lines. The readout system then displays the measurement unit and prefix for the measurement mode selected, and the decimal point is positioned properly for the measurement range selected.

Also, a positive polarity symbol (+) is encoded by the MODE/RANGE switch when set for DC VOLTS, DC CURRENT, and TEMPERATURE measurements. If the $\overline{\text{MINUS}}$ input to the base of Q278 goes to a LO level, current is added to the Column Current output through R277 and CR278 during TS-3. This added current in TS-3 results in the + symbol being changed to —.

Over-Range Indicator

The Over-Range Indicator, consisting of Q232 and Q228, causes the readout display (for the 7D13 only) to blink when the measurement range in use is exceeded.

The $\overline{2000}$ input to the base of Q228 from the Storage Registers is HI when the most significant digit is 1 or 0. This HI level saturates Q228 to sink the current through R234 when it is interrogated by time-slot pulse TS-1. The base of Q228 goes LO when the most significant digit is 2 to reverse-bias Q228. Now, when R234 is interrogated by TS-1, a JUMP instruction is added to the Row Current output.

The input to Q232 base is the LAST COUNT pulse from the counter which goes HI at the last count (approximately five hertz repetition rate). Each time the LAST COUNT goes HI, Q232 is saturated to sink the JUMP instruction current to ground. This causes the display to blink at the repetition rate of the LAST COUNT.

Zero-Cancel. Zero cancelling is encoded when the most significant digit is 0, so that the 0 does not appear in the readout display. This is accomplished during time-slot four, since this is the position held by the most significant digit.

The base of Q238 is connected to pin 9-U224 in the Storage Register circuit. The $\overline{1000}$ input to Q238 is LO when the most significant digit is 0, and HI for any other value. A HI level on the base of Q238 saturates it to sink the TS-4 current through R239 to ground. A LO level at the base of Q238 allows the TS-4 current through R239 to pass to the Row Current output through CR239. This current forces a skip in time-slot four, thus cancelling the initial 0.

TEMPERATURE MEASUREMENT AND FLOATING POWER SUPPLY

Temperature Measurement

General. The Temperature Measurement circuit consists of an emitter coupled multivibrator triggered by the two kilohertz signal from the Counter circuit Q301-Q305, current level switch Q315, demodulator FETs Q326-Q330, operational amplifier U319, and operational amplifier U335.

Theory of operation. Under the conditions of zero collector-base voltage and sufficient emitter-base voltage, the collector current of a transistor can be expressed as an exponential function of the emitter-base voltage and the junction temperature. By switching the collector current between two levels, the resulting difference in emitter-base voltage is a linear function of temperature.

Circuit operation. The temperature-sensing transistor is connected in the feedback loop (via the PROBE connector) of operational amplifier U319 with the collector at the minus input, and the emitter connected to the output through R320. The base is grounded.

The collector current of the temperature-sensing transistor is switched between two levels by Q315. The current is limited by R317 when Q315 is off, to about one-tenth the current through both R317 and R315-Q315 when Q315 is on.

For a given current input, the output of U319 forward biases the emitter-base junction of the temperature-sensing transistor to the level necessary to maintain the input collector current. Input current to the operational amplifier is negligible, and thus the input current essentially is the collector current of the temperature-sensing transistor.

The output of U319 at pin 6 is a two kilohertz square wave (and a DC component) with an amplitude determined by the temperature of the temperature-sensing transistor. This signal is AC-coupled through C329 to the drains of Q326 and Q330.

Q326 and Q330 demodulate the signal from the output of U319. Q326-Q330 are driven from opposite halves of multivibrator Q301-Q305, to be turned on during opposite half cycles. When Q326 turns on, it restores the negative extremity of the square wave signal to ground. When Q326 is off and Q330 on, the positive extremity is passed through Q330 to C332. C332 acts as a low-pass filter. The voltage developed across C332 is the demodulated output of U319, and its level follows the average amplitude of the square waves.

Circuit Description—7D13

The voltage developed across C332 is connected to the plus input of the output operational amplifier, U335. The output of U335 at pin 6 is fed back to the minus input through R337 and R339. R337, (temperature) Gain, provides adjustment of the feedback to the minus input so that the output of U335 can be calibrated to be 10 millivolts per degree Celsius. R346, Offset, adjusts the bias on U335 for an output of 0 volts when the temperature of the temperature-sensing transistor is zero degrees Celsius.

The voltage output of U335 is connected directly to the front-panel TEMP OUT connectors to provide an analog temperature signal. This voltage output is also connected to the input of the $|G_m|$ Converter when the MODE/RANGE switch is set to TEMPERATURE. This voltage is measured by the voltmeter circuits and read out as a temperature measurement.

Floating Power Supply

The Floating Power Supply is a DC-to-DC Converter supplying outputs of +15 volts, -15 volts, and +5 volts from the +15-volt supply in the Indicator Oscilloscope.

The Floating Power Supply consists of inverter Q408-Q415. Emitter-follower Q401 drives Q408 through R404 from the 40 kilohertz Clock pulse.

The center-tapped primary winding of transformer T420 is the collector load for Q408 and Q415. Since only Q408 or Q415 is conducting at any one time, the inverter is chopping at a 20 kilohertz rate, or one-half the input frequency.

The secondary windings of T420 provide a square-wave output to bridge rectifiers CR422 and CR440. Each bridge consists of four separate diodes. Each output of the Floating Power Supply is regulated by a series regulator transistor; Q433, Q438, and Q447 for the +15-volt, -15-volt, and +5-volt outputs respectively. The output volt-

age for each supply is determined by a temperature-compensating zener reference diode which sets the base voltage of the series regulator transistor.

INTRODUCTION TO THE READOUT SYSTEM

Introduction

The following discussion is provided to acquaint the 7D13 user with the Readout System used in Tektronix 7000-series Oscilloscopes. Since the oscilloscope Readout System provides the digital readout for the 7D13, it is necessary to relate the function of the 7D13 to the Readout System to gain a better understanding of the 7D13 operation. A detailed circuit description of the 7000-series Readout System is given in the oscilloscope instruction manual.

The Readout System

The Readout System in the 7000-series oscilloscopes provides alpha-numeric display of information encoded by the plug-in units. This display is presented on the CRT, and is written by the CRT beam on a time-shared basis with the analog waveform display.

The Readout System produces a pulse train consisting of 10 negative-going pulses called time-slots. These pulses are assigned time-slot numbers corresponding to their relative position in the pulse train. Each time-slot pulse is directed to one of ten output lines, labeled TS-1 through TS-10 (time-slots one through ten) and are connected to the vertical and horizontal plug-in compartments. Two output lines, row and column, are connected from each channel (two channels per plug-in compartment) back to the Readout System.

Data is encoded on these output lines either by connecting resistors between them and the time-slot input lines or by generating equivalent currents. The resultant output is a sequence of analog current levels on the row and column output lines. The row and column current levels are decoded by the Readout System to address a character matrix during each time-slot, thus selecting a character to be displayed or a special instruction to be followed.

SECTION 4

MAINTENANCE

Change information, if any, affecting this section will be found at the rear of this manual.

Introduction

This section of the manual contains maintenance information for use in preventive maintenance, corrective maintenance, and troubleshooting of the 7D13.

Further maintenance information relating to component color codes and soldering techniques can be found in the instruction manuals for the 7000-series oscilloscopes.

PREVENTIVE MAINTENANCE

General

Preventive maintenance, consisting of cleaning, visual inspection, lubrication, etc., performed on a regular basis, will improve the reliability of this instrument. Periodic checks on the semiconductor devices used in the unit are not recommended as a preventive maintenance measure. See semiconductor-checking information given under Troubleshooting.

Cleaning



Avoid the use of chemical cleaning agents which might damage the plastics in this instrument. Avoid chemicals containing benzene, toluene, xylene, acetone, or similar solvents.

Front Panel. Loose dust may be removed with a soft cloth or a dry paint brush. Water and mild detergent may be used; however, abrasive cleaners should not be used.

Interior. Cleaning the interior of the unit should precede calibration, since the cleaning process could alter the settings of the calibration adjustments. Use low-velocity compressed air to blow off the accumulated dust. Hardened dirt can be removed with a soft, dry paint brush, cotton-tipped swab, or cloth dampened with a mild detergent and water solution.

Lubrication

Use a cleaning-type lubricant on shaft bushings, interconnecting plug contacts, and switch contacts. Lubricate switch detents with a heavier grease. A lubrication kit containing the necessary lubricating materials and instructions is available through any Tektronix Field Office. Order Tektronix Part Number 003-0342-00.

Recalibration

To ensure accurate measurements, the 7D13 should be checked after each 1000 hours of operation or every six months if used infrequently. A complete performance check procedure is given in Part I of Section 5.

The performance check procedure can be helpful in isolating major troubles in the unit. Moreover, minor troubles not apparent during regular operation may be revealed and corrected.

TROUBLESHOOTING

General

The following is provided to augment information contained in other sections of this manual when troubleshooting the 7D13. The schematic diagrams, Circuit Description, and Calibration sections should be used to full advantage. The Circuit Description section gives detailed information on circuit behavior and output requirements.

Troubleshooting Aids

Diagrams. Circuit diagrams are given on foldout pages in Section 7. The circuit number and electrical value of each component in this instrument are shown on the diagrams. Important voltages are also shown.

Circuit Board. The circuit board used in the 7D13 is outlined on the schematic diagrams, and a photograph of the board is shown on the back of the Block Diagram. Each board-mounted electrical component is identified on the photograph by its circuit number.

Component and Wiring Color Code. Colored stripes or dots on resistors and capacitors signify electrical values,

Maintenance—7D13

tolerances, etc., according to the EIA standard color code. Components not color coded usually have the value printed on the body.

The insulated wires used for interconnection in the 7D13 are color coded to facilitate tracing a wire from one point to another in the unit.

Semiconductor Lead Configuration. Fig. 4-1 shows the lead configuration of the semiconductor devices used in this instrument.

Troubleshooting Equipment

The following equipment is useful for troubleshooting the 7D13:

1. **Semiconductor Tester**—Some means of testing the transistors, diodes, and FET's used in this instrument is helpful. A transistor-curve tracer such as the Tektronix Type 576 will give the most complete information.

2. **DC Voltmeter and Ohmmeter**—A voltmeter for checking voltages within the circuit and an ohmmeter for checking resistors and diodes are required.

3. **Test Oscilloscope**—A test oscilloscope is required to view waveforms at different points in the circuit.

A Tektronix 7000-series Oscilloscope with 7D13 Digital Multimeter unit, 7B-series Time-Base unit, and a 7A-series Amplifier unit with a 10X probe will meet the needs for items 2 and 3.

Troubleshooting Procedure

This troubleshooting procedure is arranged in an order which checks the simple trouble possibilities before proceeding with extensive troubleshooting.

1. **Check Control Setting.** An incorrect setting of the MODE/RANGE switch can indicate a trouble that does not exist. If there is any question about the correct function or operation of the MODE/RANGE control or of any front-panel connector, see the Operating Instructions section.

2. **Check Associated Equipment.** Before proceeding with troubleshooting of the 7D13, check that the equipment used with this instrument is operating correctly. If possible, substitute a multimeter unit known to be operating correctly into the indicator unit and see if the problem persists. Check that the input is properly connected and that the interconnecting leads are not defective.

3. **Visual Check.** Visually check the portion of the instrument in which the trouble is suspected. Many troubles can be located by visual indications, such as unsoldered connections, broken wires, damaged circuit boards, damaged components, etc.

4. **Check Instrument Performance.** Check the calibration of the unit, or the affected circuit by performing Part I — Performance Check Procedure of Section 5. The apparent trouble may only be a result of misadjustment and may be corrected by calibration. Complete calibration instructions are given in Part II of Section 5.

5. **Check Voltages and Waveforms.** Often the defective component or stage can be located by checking for the correct voltage or waveform in the circuit. Typical voltages and waveforms are given on the diagrams; however, these are not absolute and may vary slightly between instruments. To obtain operating conditions similar to those used to take these readings, see the instructions in the Diagrams section.

6. **Check Individual Components.** The following methods are provided for checking the individual components in the 7D13. Components which are soldered in place are best checked by disconnecting one end to isolate the measurement from the effects of surrounding circuitry.

A. TRANSISTORS AND INTEGRATED CIRCUITS.

The best check of transistor and integrated circuit operation is actual performance under operating conditions. If a transistor or integrated circuit is suspected of being defective, it can best be checked by substituting a component known to be good; however, be sure that circuit conditions are not such that a replacement might also be damaged. If substituting transistors are not available, use a dynamic tester (such as Tektronix Type 576). Static-type testers may be used, but since they do not check operation under simulated operating conditions, some defects may go unnoticed. Fig. 4-1 shows base pin and socket arrangements of semiconductor devices. Be sure the power is off before attempting to remove or replace any transistor or integrated circuit.

Integrated circuits can be checked with a voltmeter, test oscilloscope, or by direct substitution. A good understanding of the circuit description is essential to troubleshooting circuits using integrated circuits. Use care when checking voltages and waveforms around the integrated circuits so that adjacent leads are not shorted together. An integrated-circuit test clip provides a convenient means of clipping a test probe to the 14- and 16-pin integrated circuits. This device also doubles as an integrated-circuit extraction tool.

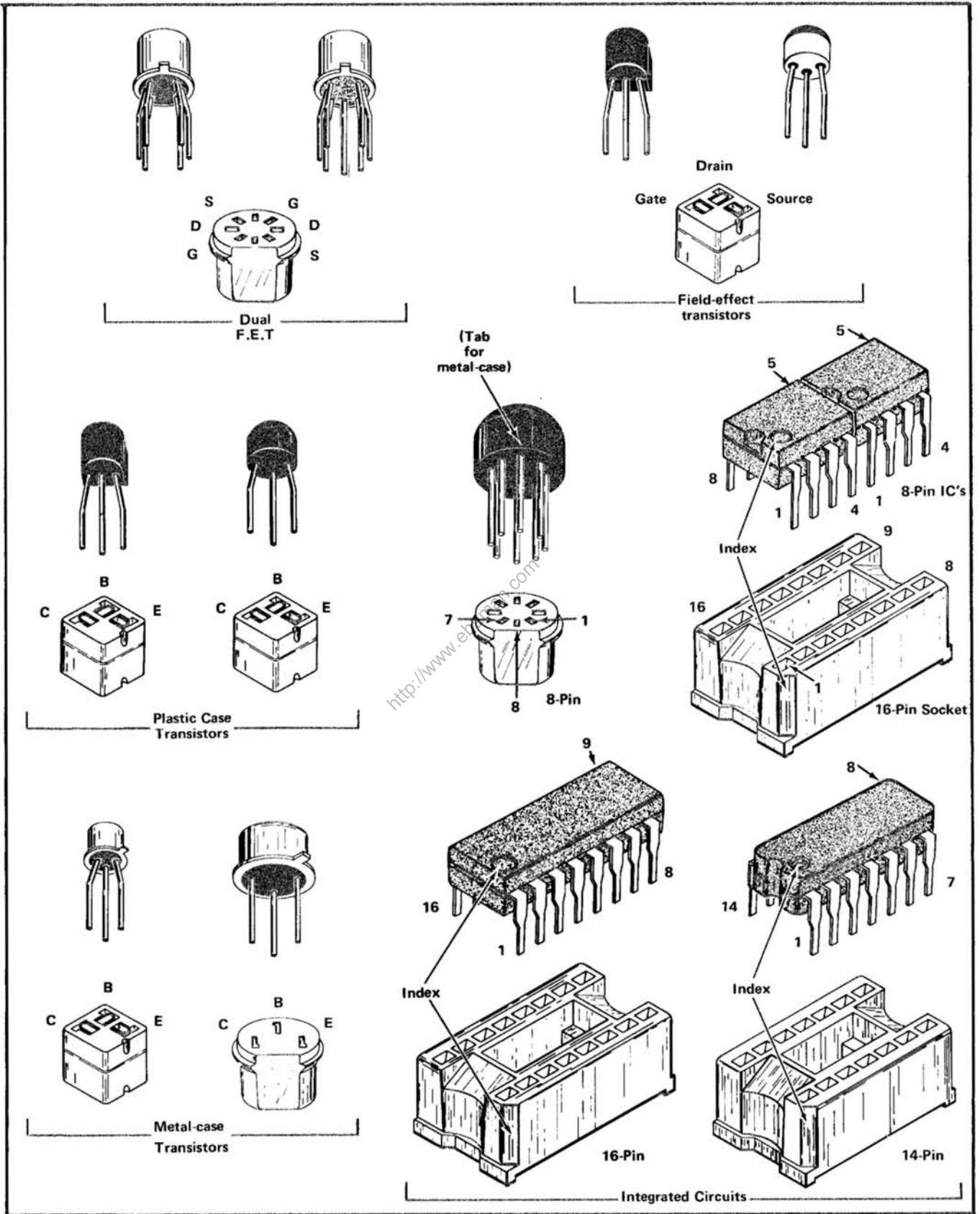

Fig. 4-1. Electrode configuration for semiconductors used in this instrument.

B. DIODES. A diode can be checked for an open or shorted condition by measuring the resistance between terminals. With an ohmmeter scale having an internal source of between 800 millivolts and 3 volts, the resistance should be very high in one direction and very low when the leads are reversed.



Do not use an ohmmeter scale that has a high internal current. High currents may damage the diodes.

C. RESISTORS. Check resistors with an ohmmeter. Resistor tolerance is given in the Electrical Parts List. Resistors normally do not need to be replaced unless the measured value varies widely from the specified value.

D. CAPACITORS. A leaky or shorted capacitor can be detected by checking resistance with an ohmmeter on the highest scale. Use an ohmmeter which will not exceed the voltage rating of the capacitor. The resistance reading should be high after initial charge of the capacitor. An open capacitor can best be detected with a capacitance meter, or by checking whether the capacitor passes AC signals.

7. Repair and Readjust the Circuit. Special techniques required to replace components in this unit are given under Component Replacement. Be sure to check the performance of any circuit that has been repaired or that has had any electrical components replaced. Recalibration of the affected circuit may be necessary.

REPLACEMENT PARTS

Standard Parts

All electrical and mechanical part replacements for the 7D13 can be obtained through your local Tektronix Field Office or representative. However, many of the standard electronic components can be obtained locally in less time than is required to order them from Tektronix, Inc. Before purchasing or ordering replacement parts, check the parts lists for value, tolerance, rating, and description.

NOTE

When selecting replacement parts, it is important to remember that the physical size and shape of the component may affect its performance in the instrument. All replacement parts should be direct replacements unless it is known that a different component will not adversely affect the instrument performance.

Special Parts

Some parts are manufactured or selected by Tektronix to satisfy particular requirements, or are manufactured for Tektronix to our specifications. These special parts are indicated in the parts list by an asterisk preceding the part number. Most of the mechanical parts used in this instrument have been manufactured by Tektronix. Order all special parts directly from your local Tektronix Field Office or representative.

Ordering Parts

When ordering replacement parts from Tektronix, Inc., refer to the Parts Ordering Information and Special Notes and Symbols on the page immediately preceding the Electrical Parts List section. Include the following information:

1. Instrument type (7D13)
2. Instrument Serial Number
3. A description of the part (if electrical, include the circuit number)
4. Tektronix Part Number

COMPONENT REPLACEMENT

General

The exploded-view drawing associated with the Mechanical Parts List may be helpful when disassembling or reassembling individual components or sub-assemblies.

Circuit Board Replacement

In general, the circuit board used in the 7D13 needs never be removed unless it must be replaced. Electrical connections to the board are made by two methods: solderless pin connections and a solder lug.

To remove or replace the board, proceed as follows:

1. Disconnect all leads connected to the board.
2. Remove all the screws holding the board to the chassis or other mounting surface.
3. Remove the screws holding the plastic plug-in guide to the top and bottom frame sections.
4. Remove the board from the unit and from the plastic guide. Do not force or bend the board.

5. To replace the board, reverse the order of removal. Replace the pin connectors carefully so they mate correctly with the pins. If forced into place incorrectly positioned, the pin connectors may be damaged. As a guide, correct connections of the wires are given in the diagrams section.

Switch Replacement

Single wafers on the MODE/RANGE switch are not normally replaced. If any part of the MODE/RANGE switch is defective, the entire switch should be replaced. A new switch can be ordered through your Tektronix Field Office.

CAUTION

When disconnecting or connecting leads to a wafer-type rotary switch, do not let solder flow around and beyond the rivet on the switch terminal. Excessive solder can destroy the spring tension of the contact.

PROBE Connector Replacement

If it is necessary to replace the PROBE connector, first draw a sketch of the connector terminals and record the wire color at each terminal. Unsolder the wires using a 35- to 40-watt pencil-type soldering iron. A heat sink should be replaced on the wire ends to prevent heat damage to the wire insulation. Remove the nut and lockwasher holding the connector to the front panel using a 9/16-inch open-end wrench; then remove the connector.

High voltages can appear between the terminals or between the terminals and ground when making measure-

ments; therefore, care must be taken when reconnecting the wires. The wires must be soldered to the inside surface of the terminals. Use a heat sink on the wire ends to prevent heat damage to the wire insulation. Remove all frayed wire ends and pieces of solder from the terminals.

Transistor and Integrated Circuit Replacement

Transistors and IC's should not be replaced unless they are actually defective. If removed from their sockets during routine maintenance, return them to their original sockets. Special care must be given to integrated circuit leads, because they can easily be damaged in removal from sockets. Unnecessary replacement or switching of components may affect the calibration of the instrument. When a transistor is replaced, check the operation of that part of the instrument that may be affected.

Fuse Replacement

The fuses for the measuring circuits are located on the front of the circuit board. See the electrical parts list for the values of the fuses.

RECALIBRATION AFTER REPAIR

After any electrical component has been replaced, the calibration of that particular circuit should be checked, as well as the calibration of other closely related circuits. The Performance Check instructions given in Part I of Section 5 provide a quick and convenient means of checking the instrument operation. The Calibration Procedure in Part II of Section 5 can then be used to adjust the operation to meet the specifications listed in Section 1.

SECTION 5

CALIBRATION

Change information, if any, affecting this section will be found at the rear of this manual.

Introduction

To assure instrument accuracy, check the calibration of the 7D13 every 1000 hours of operation, or every six months if used infrequently. Before complete calibration, thoroughly clean and inspect this instrument as outlined in the Maintenance section.

Tektronix Field Service

Tektronix, Inc. provides complete instrument repair and recalibration at local Field Service Centers and the Factory Service Center. Contact your local Tektronix Field Office or representative for further information.

Using This Procedure

General. This section provides several features to facilitate checking or adjusting the 7D13. These are:

Performance Check. The performance of this instrument can be checked without removing the side shields or making internal adjustments by performing only Part I — Performance Check. This procedure checks the instrument against the tolerances listed in the Performance Requirement column of Section 1. In addition, a cross-reference is provided to the step in Part II — Adjustment which will return the instrument to correct calibration. In most cases, the adjustment step can be performed without changing control settings or equipment connections.

Adjustment Procedure. To return this instrument to correct calibration with the minimum number of steps, perform only Part II — Adjustment. The Adjustment procedure gives the recommended calibration procedure for all circuits in this instrument. It also includes check procedures for those functions which cannot be checked without removing the side shields (e.g., Floating Power Supply output voltages). Procedures are not given for checks which can be made without removing the shields; see Part I — Performance Check for the procedure for these checks.

Partial Procedure. A partial check or adjustment is often desirable after replacing components or to touch

up the adjustment of a portion of the instrument between major recalibrations. To check or adjust only part of the instrument, start with the nearest Equipment Required list preceding the desired portion. To prevent unnecessary recalibration of other parts of the instrument, readjust only if the tolerance given in the CHECK— part of the step is not met. If re-adjustment is necessary, also check the calibration of any steps listed in the INTERACTION— part of the step.

Complete Performance Check/Adjustment. To completely check and adjust all parts of this instrument, perform both Parts I and II. Start the complete procedure by performing the Clock and Zero adjustments as given in the Adjustment procedure. Then perform the Adjustment procedure for a portion of the instrument (e.g., DC VOLTS and DC CURRENT Measurement Adjustment), and follow this with the Performance Check for the same portion (e.g., DC VOLTS and DC CURRENT Measurement Accuracy Check). This method will assure that the instrument is both correctly adjusted and performing within all given specifications.

TEST EQUIPMENT REQUIRED

General

The following test equipment and accessories, or its equivalent, is required for complete calibration of the 7D13. Specifications given for the test equipment are the minimum necessary for accurate calibration. Therefore, some of the specifications listed here may be somewhat less precise than the actual performance capabilities of the test equipment. All test equipment is assumed to be correctly calibrated and operating within the listed specifications.

The Performance Check and Adjustment procedures are based on this recommended equipment. If other equipment is substituted, control settings or calibration setup may need to be altered to meet the requirements of the equipment used. Detailed operating instructions for the test equipment are not given in this procedure. Refer to the instruction manual for the test equipment if more information is needed.

Calibration Equipment Alternatives

All of the test equipment is required to completely check and adjust this instrument. However, some of the items used only for the Performance Check can be deleted without compromising the instrument's measurement capabilities. For example, the DC current standard is used only in the Performance Check and may be deleted if the user does not desire to check the accuracy of the DC CURRENT measurement mode. Equipment used only for the Performance Check procedure is indicated by footnote 1; items required only for the Adjustment procedure are indicated by footnote 2.

Test Equipment

1. 7000-series oscilloscope equipped with a readout system, referred to as the Indicator Oscilloscope in this procedure. For example, a Tektronix 7503 Oscilloscope.

2. DC Voltage Standard. Range, 0 volts to 1000 volts; accuracy, within 0.01%. For example, Fluke Model 341A Voltage Calibrator.

3. DC Current Standard.¹ Range, 0 to 2 amperes; accuracy, within 0.05%. For example, Fluke Model 382A Voltage/Current Calibrator.

4. Resistance Standard. Range, 200 ohms to 2 meg-ohms; accuracy, within 0.05%. For example, Electro Scientific Industries Model DB52 Decade Resistor.

5. Temperature Bath and Bath Cooler. Range, 0°C to +125°C. For example, Neslab Instruments Model TE9/100 Stirred Bath and Model PBC-4 Bath Cooler.

¹Used only for Performance Check procedure.

6. Oil Testing Thermometer. Range, 0°C and +125°C; accuracy, within 1/5°C. For example, ASTM 67C; Nurnberg Catalog Number 5790.

7. Temperature Probe Equalizing Block. See Addendum to this procedure.

8. Digital Voltmeter. Range, 20 volts; accuracy, within 0.1%. For example, Tektronix 7D13 Digital Multi-meter Plug-In.

9. Digital Counter.² Range, 100 kHz; resolution, at least 0.05 kilohertz. For example, Tektronix 7D14 Digital Counter Plug-In.

Accessories

10. P6058 Voltage/Temperature Probe (supplied accessory). Tektronix Part Number 010-0260-00.

11. Patch Cords (Three required). Connectors, Banana Plug-Jack to Banana Plug-Jack; length, 18 inches. Tektronix Part Number 012-0031-00 (red); Tektronix Part Number 012-0039-00 (black).

Adjustment Tools

12. Screwdriver.² Three-inch shaft; 3/32-inch wide bit for slotted screws. For example, Xcelite R-3323.

²Used only for Adjustment procedure.

PART I – PERFORMANCE CHECK

Introduction

The following procedure checks the performance of the 7D13 without removing the side shields or making internal adjustments. All tolerances given in this procedure are based on Section 1 of this manual.

Preliminary Procedure for Performance Check

NOTE

The performance of this instrument can be checked at any temperature within the +15°C to +40°C range unless stated otherwise.

1. Install the 7D13 in any plug-in compartment of the Indicator Oscilloscope.

2. Connect the Indicator Oscilloscope to a power source which meets the frequency and voltage requirements of the oscilloscope power supply.

3. Turn the Indicator Oscilloscope power on. Allow at least twenty minutes warmup for checking the 7D13 to the given accuracy.

4. Set the controls as follows:

	7D13
MODE/RANGE	DC VOLTS/2 V (orange front-panel tint)

Indicator Oscilloscope

Intensity	Counterclockwise
Readout	Off

Any controls not mentioned can be set as desired.

5. Advance the Indicator Oscilloscope Readout control to obtain a usable readout display. Adjust the Focus and Astigmatism controls as necessary for well-defined characters in the display.

DC VOLTS AND DC CURRENT MEASUREMENT ACCURACY CHECK

Equipment Required

1. Indicator Oscilloscope
2. DC voltage standard
3. DC current standard
4. Banana-plug patch cords (three required)
5. P6058 probe

Control Settings

Set the 7D13 MODE/RANGE switch to DC VOLTS/2 V. (The orange-tinted area of the front panel indicates the ranges used for measurements via the INPUT connectors.)

1. Check DC VOLTS Measurement Accuracy

a. Connect a banana-plug patch cord between the 7D13 COM INPUT connector and the ground post connector on the Indicator Oscilloscope.

b. Set the output of the DC voltage standard to zero.

c. Using two banana-plug patch cords, connect the 7D13 HIGH and COM INPUT connectors to the plus (+) and minus (–) output terminals respectively on the DC voltage standard.

d. CHECK—Set the 7D13 MODE/RANGE switch and the output of the DC voltage standard to the settings given in Table 5-1. The readout display should show a positive voltage (a “+” symbol preceding the voltage reading) within the limits given for each MODE/RANGE switch setting and DC voltage standard output listed in Table 5-1.

e. CALIBRATION—See step 4 of the Adjustment procedure.

f. Set the output of the DC voltage standard to zero.

TABLE 5-1

7D13 MODE/RANGE Switch	DC Voltage Standard Output	Readout Limits	
		Min.	Max.
DC VOLTS/2 V	2.0000 V	1.997 V	2.003 V
DC VOLTS/20 V	2.0000 V	1.99 V	2.01 V
DC VOLTS/20 V	20.000 V	19.97 V	20.03 V
DC VOLTS/200 V	20.000 V	19.9 V	20.1 V
DC VOLTS/200 V	200.00 V	199.7 V	200.3 V
DC VOLTS/1 kV	200.00 V	199 V	201 V
DC VOLTS/1 kV	1000.0 V	998 V	1002 V

g. Connect the 7D13 HIGH and COM INPUT connectors to the minus (-) and plus (+) output terminals respectively on the DC voltage standard.

h. CHECK--Set the 7D13 MODE/RANGE switch and the output of the DC voltage standard to the settings given in Table 5-1. The readout display should show a negative voltage (a "-" symbol preceding the voltage reading) within the limits given for each MODE/RANGE switch setting and DC voltage standard output listed in Table 5-1.

i. Set the 7D13 MODE/RANGE switch to DC VOLTS/2 V and the output of the DC voltage standard to 20 volts.

j. CHECK--The readout display for the 7D13 should blink to indicate an over-range measurement.

k. Set the output of the DC voltage standard to zero and remove the patch-cord connections between the 7D13 and the DC voltage standard.

2. Check PROBE DC VOLTS Measurement Accuracy

a. Connect the P6058 Voltage/Temperature probe to the 7D13 PROBE connector.



When connecting the Voltage/Temperature Probe to the PROBE connector, the two connectors must be correctly aligned. Damage to the terminals can result from forcing the connector and jack together. Refer to the probe instruction manual.

b. Set the 7D13 MODE/RANGE switch to DC VOLTS/2 V. (The DC VOLTS ranges in the dark-gray area of the

front panel are used for voltage measurements with the probe.)

c. Set the output of the DC voltage standard to zero.

d. Connect the probe tip and common strap to the plus (+) and minus (-) output terminals respectively on the DC voltage standard.

e. CHECK--The readout display should show a positive voltage (a "+" symbol preceding the voltage reading) within the limits given for each MODE/RANGE switch setting and DC voltage standard output listed in Table 5-1.

f. Set the output of the DC voltage standard to zero and disconnect the probe tip and common strap.

g. Disconnect the P6058 probe from the 7D13 PROBE connector.

3. Check DC CURRENT Measurement Accuracy

a. Set the MODE/RANGE switch to DC CURRENT/2 mA.

b. Set the output of the DC current standard to zero.

c. Using banana-plug patch cords, connect the HIGH and COM INPUT connectors on the 7D13 to the plus (+) and minus (-) output terminals respectively on the DC current standard.

d. CHECK--The readout display should show a plus current value (a "+" symbol preceding the reading) within the limits given for each MODE/RANGE switch setting and DC current standard output listed in Table 5-2.

e. Set the output of the DC current standard to zero.

f. Connect the HIGH and COM INPUT connectors to the minus and plus output terminals respectively on the DC current standard.

g. CHECK--The readout display should show a minus current value (a "-" symbol preceding the reading) within the limits given for each MODE/RANGE switch setting and DC current standard output current listed in Table 5-2.

h. Set the output of the DC current standard to zero and remove the patch cord connections between the 7D13 INPUT connectors and the DC current standard.

TABLE 5-2

DC CURRENT Measurement Accuracy

7D13 MODE/RANGE Switch	DC Current Standard Output	Readout Limits	
		Min.	Max.
DC CURRENT/2 mA	2.0000 mA	1.988 mA	2.012 mA
DC CURRENT/20 mA	2.0000 mA	1.97 mA	2.03 mA
DC CURRENT/20 mA	20.000 mA	19.88 mA	20.12 mA
DC CURRENT/200 mA	20.000 mA	19.7 mA	20.3 mA
DC CURRENT/200 mA	200.00 mA	198.8 mA	201.2 mA
DC CURRENT/2 A	200.00 mA	197 mA	203 mA
DC CURRENT/2 A	2.0000 A	1988 mA	2012 mA

RESISTANCE MEASUREMENT ACCURACY CHECK

Equipment Required

1. Indicator Oscilloscope
2. Resistance standard
3. Banana-plug patch cords (two required)

Control Settings

Set the 7D13 MODE/RANGE switch to RESISTANCE/200 Ω .

4. Check RESISTANCE Measurement Accuracy

a. Connect the 7D13 INPUT connectors to the resistance standard, using banana-plug patch cords.

b. CHECK—The readout display should show a value of resistance within the limits given for each MODE/RANGE switch setting and resistance standard value listed in Table 5-3.

c. CALIBRATION—See step 5 of the Adjustment procedure.

d. Disconnect the patch-cord connections between the 7D13 INPUT connectors and the resistance standard.

TABLE 5-3
RESISTANCE Measurement Accuracy

7D13 MODE/RANGE Switch	RESISTANCE Standard	Readout Limits	
		Min.	Max.
RESISTANCE/200 Ω	200.0 Ω	198.9 Ω	201.1 Ω
RESISTANCE/2 k Ω	200.0 Ω	198 Ω	202 Ω
RESISTANCE/2 k Ω	2000 Ω	1989 Ω	2011 Ω
RESISTANCE/20 k Ω	2000 Ω	1.98 k Ω	2.02 k Ω
RESISTANCE/20 k Ω	20.00 k Ω	19.89 k Ω	20.11 k Ω
RESISTANCE/200 k Ω	20.00 k Ω	19.8 k Ω	20.2 k Ω
RESISTANCE/200 k Ω	200.0 k Ω	198.9 k Ω	201.1 k Ω
RESISTANCE/2 M Ω	200.0 k Ω	198 k Ω	202 k Ω
RESISTANCE/2 M Ω	2.000 M Ω	1989 k Ω	2011 k Ω

TEMPERATURE MEASUREMENT CHECK

Equipment Required

1. Indicator Oscilloscope
2. P6058 probe
3. Temperature bath and bath cooler
4. Oil testing thermometer
5. Temperature probe equalizing block
6. Digital voltmeter

Control Settings

Set the 7D13 MODE/RANGE control to TEMPERATURE.

5. Check TEMPERATURE Measurement Accuracy and TEMP OUT Accuracy

a. Connect the P6058 probe to the 7D13 PROBE connector.

CAUTION

When connecting the P6058 probe to the PROBE connector, the two connectors must be correctly aligned. Damage to the terminals can result from forcing the connector and jack together.

b. Install the P6058 probe and the oil-testing thermometer in the holes in the temperature-probe equalizing block. (Use the dielectric coolant given in Fig. 5-2.)

Performance Check—7D13

c. Suspend the temperature-probe equalizing block in the temperature bath, making sure that the top surface of the block is not submerged.

d. Set the temperature bath and bath cooler for 0°C.

e. CHECK—When the temperature bath has reached 0°C as indicated by the oil-testing thermometer, the 7D13 readout display should read 0C, plus or minus 1°C (–1C to +1C).

f. Connect the digital voltmeter to the TEMP OUT pin-jack connectors.

g. CHECK—The digital voltmeter should read 0 volt, plus or minus 10 mV.

h. CALIBRATION—See step 6 of the Adjustment procedure.

i. Set the temperature bath for +125°C.

j. CHECK—When the temperature bath has reached +125°C as indicated by the oil-testing thermometer, the

7D13 readout display should show +125C, plus or minus 1°C (+124C to +126C).

k. CHECK—The digital voltmeter should read +1.25 volts, within 10 mV (+1.24 V to +1.26 V).

l. CALIBRATION—See step 7 of the Adjustment procedure.

m. Disconnect the digital voltmeter.

n. Set the temperature bath to 25°C (room temperature).

o. After allowing the temperature bath to cool, remove the temperature-probe equalizing block, P6058 probe, and the oil-testing thermometer from the bath.

p. Disconnect the P6058 probe from the 7D13.

This completes the Performance Check of the 7D13.

<http://www.abaman.com>

PART II — ADJUSTMENT

Introduction

The following procedure returns the 7D13 to correct calibration. All limits and tolerances given in this procedure are calibration guides and should not be interpreted as instrument specifications except as specified in Section 1 of this manual. The actual performance of the instrument may exceed the given limits or tolerances if the instrument meets the Performance Requirements as checked in Part I — Performance Check of this section.

Fig. 5-1 shows the locations of all adjustments and test points used in this procedure.

Preliminary Procedure For Adjustment

NOTE

This instrument should be adjusted at an ambient temperature of $25^{\circ}\text{C} \pm 5^{\circ}\text{C}$ for best overall accuracy.

1. Remove the left side shield from the 7D13, and the left side panel from the Indicator Oscilloscope.

2. Install the 7D13 in the left vertical plug-in compartment of the Indicator Oscilloscope.

3. Connect the Indicator Oscilloscope to a power source which meets the frequency voltage requirements of the oscilloscope power supply.

4. Turn the Indicator Oscilloscope power on. Allow at least twenty minutes warmup before proceeding.

5. Set the controls as follows:

7D13

MODE/RANGE DC VOLTS/2 V

Indicator Oscilloscope

Intensity Counterclockwise
Readout Off

Any controls not mentioned can be set as desired.

6. Advance the Indicator Oscilloscope Readout control to obtain a usable readout display. Adjust the Focus and Astigmatism as necessary to obtain a well-defined display.

NOTE

Titles for external controls of this instrument are capitalized in this procedure (e.g., MODE/RANGE). Internal adjustments are initial capitalized only (e.g., Clock).

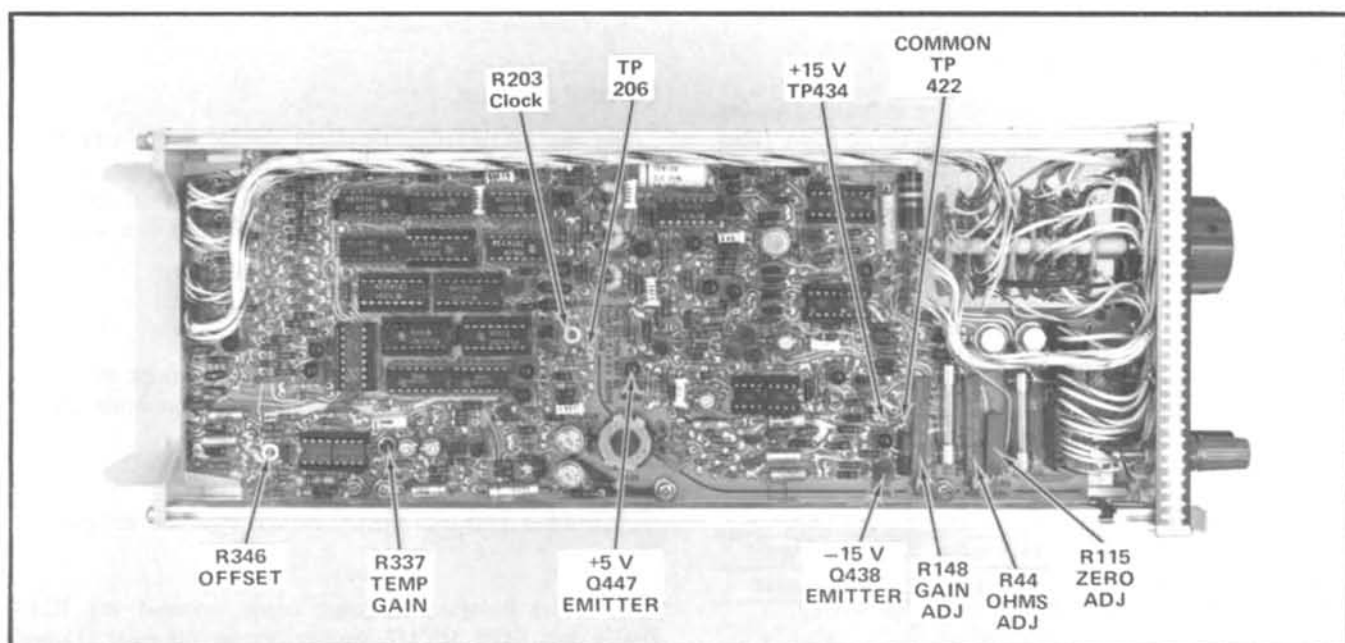

Fig. 5-1. Location of Adjustments and Test Points used in this procedure.

CLOCK AND ZERO ADJUSTMENT

Equipment Required

1. Indicator Oscilloscope
2. Digital counter
3. Digital voltmeter
4. Three-inch screwdriver

Control Settings

Set the 7D13 MODE/RANGE switch to DC VOLTS/2 V.

1. Adjust Clock Frequency

- a. Connect the digital counter between TP206 and ground.
- b. CHECK—Digital counter reading; 80 kilohertz, ± 0.5 kilohertz.
- c. ADJUST—Clock adjustment, R203, for a digital counter reading of exactly 80 kilohertz.
- d. Disconnect the counter from TP206 and ground.
- e. INTERACTION—Change in setting of R203 may affect operation of all circuits within the 7D13.

2. Check Floating Power Supply

- a. Connect the digital voltmeter from floating power supply common, TP422, to the test points listed in Table 5-4 for each floating power supply voltage.
- b. CHECK—Each floating supply for the output voltage listed. The output voltage should be within the given tolerance.

TABLE 5-4
Floating Power Supply Data

Supply	Test Point	Minimum Value	Maximum Value
+15-V	434	+14.1 volts	+15.9 volts
-15-V	439 ³	-14.1 volts	-15.9 volts
+5-V	448 ⁴	+4.7 volts	+5.3 volts

³ Q438 Emitter in early production instruments.

⁴ Q447 Emitter in early production instruments.

- c. Disconnect the digital voltmeter.

3. Adjust Zero

- a. Turn the Indicator Oscilloscope on its right side and remove the bottom cover.
- b. Set the 7D13 MODE/RANGE switch to DC CURRENT/2 mA.
- c. CHECK—7D13 readout display; .000 mA, $\pm .002$ mA ($-.002$ mA to $+.002$ mA).
- d. ADJUST—Zero Adjustment, R115, for a readout display of .000 mA. The best adjustment is obtained when the readout display just changes from $-.000$ mA to $+.000$ mA.
- e. INTERACTION—Change in setting of R115 may affect the calibration of all measurement modes.

DC VOLTS AND DC CURRENT MEASUREMENT ADJUSTMENT

Equipment Required

1. Indicator Oscilloscope
2. DC voltage standard
3. Banana-plug patch cords (three required)
4. Three-inch screwdriver

Control Settings

Set the 7D13 MODE/RANGE switch to DC VOLTS/2 V. (The 7D13 should now be installed in the left vertical plug-in compartment of the Indicator Oscilloscope. The Indicator Oscilloscope should be on its right side with the bottom cover removed.)

4. Adjust Gain

- a. Using a banana-plug patch cord, connect the 7D13 COM INPUT connector to a ground post connector on the Indicator Oscilloscope.
- b. Set the output of the DC voltage standard to zero.
- c. Using banana-plug patch cords, connect the 7D13 HIGH and COM INPUT connectors to the plus (+) and minus (-) output terminals respectively on the DC voltage standard.

d. Set the output of the DC voltage standard to 2.0000 volts.

e. CHECK--7D13 readout display; +2.000 V, ± 0.003 volt (+1.997 V to +2.003 V).

f. ADJUST--Gain Adjustment, R148, for a readout display of exactly +2.000 V.

g. Reverse the connections between the INPUT connectors and the DC voltage standard output terminals.

h. CHECK--7D13 readout display; -2.000 V.

i. ADJUST--Gain Adjustment, R148, for a readout display of exactly -2.000 V.

j. Repeat parts c through i of this step, adjusting R148 for the best compromise between the plus and minus readings.

k. Set the output of the DC voltage standard to zero; then remove the patch cords from the 7D13 INPUT connectors.

l. INTERACTION--Change in the setting of R148 may affect the calibration of the RESISTANCE and TEMPERATURE measurement modes.

RESISTANCE MEASUREMENT ADJUSTMENT

Equipment Required

1. Indicator Oscilloscope
2. Resistance standard
3. Banana-plug patch cords (two required)
4. Three-inch screwdriver

Control Settings

Set the 7D13 MODE/RANGE switch to RESISTANCE/20 k Ω . (The 7D13 should now be installed in the left vertical plug-in compartment of the Indicator Oscilloscope. The Indicator Oscilloscope should be on its right side with the bottom cover removed.)

5. Adjust Ohms

a. Connect the 7D13 INPUT connectors to the resistance standard using banana-plug patch cords.

b. Set the resistance standard for a value of 20.00 kilohms.

c. CHECK--7D13 readout display; 20.00 k Ω , ± 0.11 kilohm (19.89 k Ω to 20.11 k Ω).

d. ADJUST--Ohms Adjustment, R44, for a readout display of exactly 20.00 k Ω .

e. Remove the patch-cord connections from the 7D13 INPUT connectors and the resistance standard.

f. Replace the bottom cover on the Indicator Oscilloscope and turn the instrument upright.

TEMPERATURE MEASUREMENT ADJUSTMENT

Equipment Required

1. Indicator Oscilloscope
2. Temperature bath and bath cooler
3. P6058 probe
4. Temperature-probe equalizing block
5. Oil-testing thermometer

Control Settings

Set the 7D13 MODE/RANGE switch to TEMPERATURE.

6. Adjust (Temperature) Offset

a. Connect the P6058 probe to the front-panel PROBE connector.



When connecting the P6058 probe to the PROBE connector, the two connectors must be correctly aligned. Damage to the terminals can result from forcing the connector and jack together.

Adjustment—7D13

b. Insert the P6058 probe and the oil-testing thermometer into the holes in the temperature-probe equalizing block. (Use the dielectric coolant given in Fig. 5-2.)

c. Suspend the temperature-probe equalizing block in the temperature bath, making sure that the top of the block is not submerged.

d. Set the temperature bath for 0°C and allow it to stabilize at that temperature, as indicated by the oil-testing thermometer.

e. CHECK—7D13 readout display, $0\text{C}, \pm 1^{\circ}\text{C}$.

f. ADJUST—Offset adjustment, R346, for a readout display of exactly 0C .

7. Adjust (Temperature) Gain

a. Set the temperature bath to $+125^{\circ}\text{C}$ and allow it to stabilize at that temperature as indicated by the oil-testing thermometer.

b. CHECK—7D13 readout display; $+125\text{C}, \pm 1^{\circ}\text{C}$.

c. ADJUST—(Temperature) Gain, R337, for a readout display of exactly $+125\text{C}$.

d. Set the temperature bath for a temperature of about $+25^{\circ}\text{C}$ (ambient room temperature) and allow it to cool.

e. Remove the temperature-probe equalizing block, P6058 probe, and oil-testing thermometer from the temperature bath.

f. Disconnect the P6058 probe from the 7D13.

g. Remove the 7D13 from the Indicator Oscilloscope. Replace the side shield on the 7D13 and the left side panel on the Indicator Oscilloscope.

This completes the Adjustment procedure of the 7D13.

<http://www.ebaman.com>

ADDENDUM

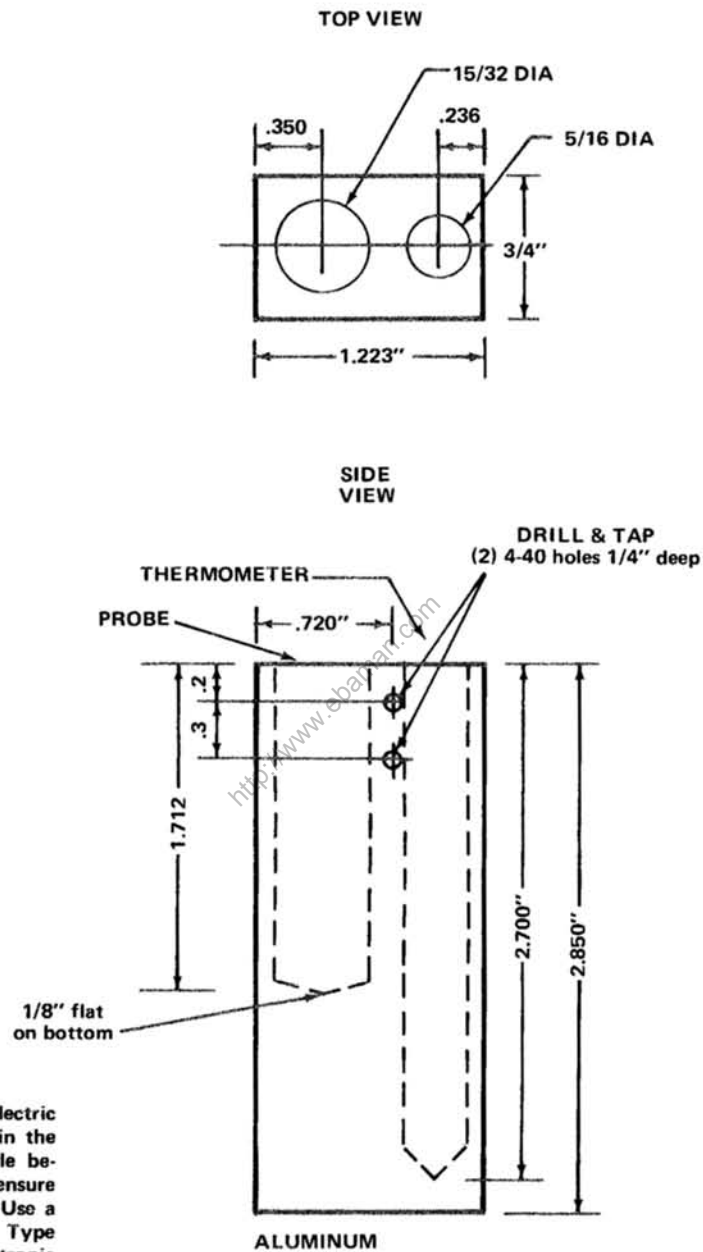

A small quantity of dielectric coolant should be placed in the equalizing block probe hole before installing the probe to ensure good thermal conduction. Use a dielectric coolant such as Type FC40 Fluorinert Brand Electronic Liquid.

Fig. 5-2. Temperature Probe Equalizing Block.

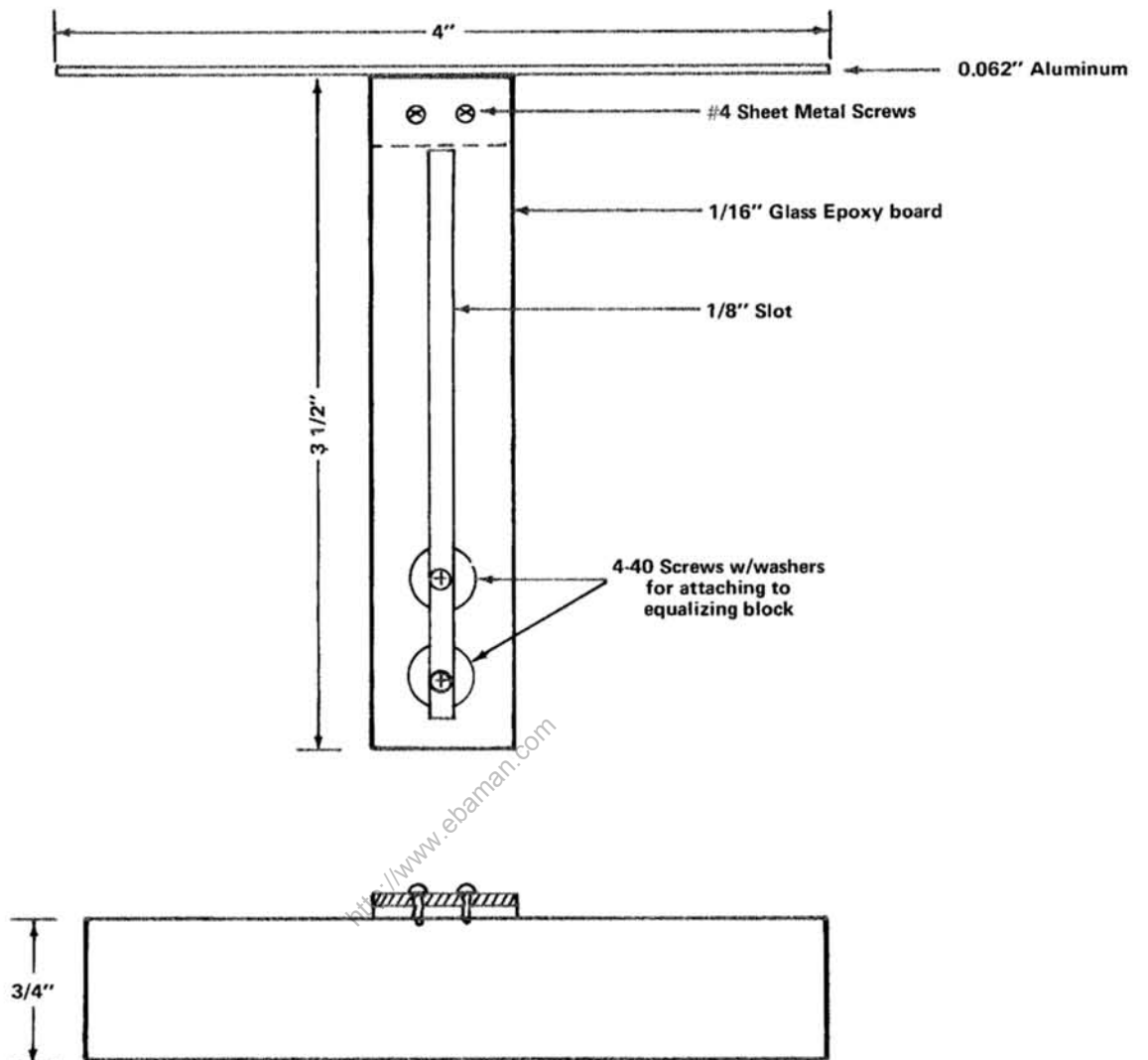

Fig. 5-3. Suspension bracket for temperature probe equalizing block.

PARTS LIST ABBREVIATIONS

BHB	binding head brass	int	internal
BHS	binding head steel	lg	length or long
cap.	capacitor	met.	metal
cer	ceramic	mtg hdw	mounting hardware
comp	composition	OD	outside diameter
conn	connector	OHB	oval head brass
CRT	cathode-ray tube	OHS	oval head steel
csk	countersunk	P/O	part of
DE	double end	PHB	pan head brass
dia	diameter	PHS	pan head steel
div	division	plstc	plastic
elect.	electrolytic	PMC	paper, metal cased
EMC	electrolytic, metal cased	poly	polystyrene
EMT	electrolytic, metal tubular	prec	precision
ext	external	PT	paper, tubular
F & I	focus and intensity	PTM	paper or plastic, tubular, molded
FHB	flat head brass	RHB	round head brass
FHS	flat head steel	RHS	round head steel
Fil HB	fillister head brass	SE	single end
Fil HS	fillister head steel	SN or S/N	serial number
h	height or high	S or SW	switch
hex.	hexagonal	TC	temperature compensated
HHB	hex head brass	THB	truss head brass
HHS	hex head steel	thk	thick
HSB	hex socket brass	THS	truss head steel
HSS	hex socket steel	tub.	tubular
ID	inside diameter	var	variable
inc	incandescent	w	wide or width
		WW	wire-wound

PARTS ORDERING INFORMATION

Replacement parts are available from or through your local Tektronix, Inc. Field Office or representative.

Changes to Tektronix instruments are sometimes made to accommodate improved components as they become available, and to give you the benefit of the latest circuit improvements developed in our engineering department. It is therefore important, when ordering parts, to include the following information in your order: Part number, instrument type or number, serial or model number, and modification number if applicable.

If a part you have ordered has been replaced with a new or improved part, your local Tektronix, Inc. Field Office or representative will contact you concerning any change in part number.

SPECIAL NOTES AND SYMBOLS

×000	Part first added at this serial number
00×	Part removed after this serial number
*000-0000-00	Asterisk preceding Tektronix Part Number indicates manufactured by or for Tektronix, Inc., or reworked or checked components.
Use 000-0000-00	Part number indicated is direct replacement.

<http://www.ebaman.com>

INDEX OF ELECTRICAL PARTS LIST

Title	Page No.
CHASSIS	6-1
DIGITAL MULTIMETER Circuit Board Assembly	6-1

<http://www.ebaman.com>

SECTION 6

ELECTRICAL PARTS LIST

Values are fixed unless marked Variable.

Ckt. No.	Tektronix Part No.	Serial/Model No. Eff	Disc	Description
----------	-----------------------	-------------------------	------	-------------

CHASSIS

Capacitors

Tolerance $\pm 20\%$ unless otherwise indicated.

C4	283-0114-00		0.0015 μF	Cer	200 V	5%
C5	283-0114-00		0.0015 μF	Cer	200 V	5%
C70	283-0065-00		0.001 μF	Cer	100 V	5%

Connectors

J1	129-0064-01			Post, binding
J2	129-0064-00			Post, binding
J5	131-1011-00			Receptacle, electrical, 4 contact, female
J70	136-0387-00			Socket, pin term.
J71	136-0387-00			Socket, pin term.

Switch

Wired or Unwired

S1	260-1214-00		Rotary	MODE/RANGE
----	-------------	--	--------	------------

DIGITAL MULTIMETER Circuit Board Assembly

*670-0994-01

Complete Board

Capacitors

Tolerance $\pm 20\%$ unless otherwise indicated.

C13	283-0003-00		0.01 μF	Cer	150 V	
C20	285-0674-00		0.01 μF	PTM	100 V	
C26	281-0546-00		330 pF	Cer	500 V	10%
C32	283-0065-00		0.001 μF	Cer	100 V	5%
C35	283-0111-00		0.1 μF	Cer	50 V	

DIGITAL MULTIMETER Circuit Board Assembly (cont)

Ckt. No.	Tektronix Part No.	Serial/Model No. Eff	Disc	Description		
Capacitors (cont)						
C47	283-0111-00			0.1 μ F	Cer	50 V
C100	285-0566-00			0.022 μ F	PTM	200 V
C104	281-0546-00			330 pF	Cer	500 V
C108	283-0111-00			0.1 μ F	Cer	50 V
C111	283-0111-00			0.1 μ F	Cer	
C118	283-0065-00			0.001 μ F	Cer	100 V
C119	283-0110-00			0.005 μ F	Cer	150 V
C124	283-0177-00			1 μ F	Cer	25 V
C128	283-0111-00			0.1 μ F	Cer	50 V
C130	283-0003-00			0.01 μ F	Cer	150 V
C132	283-0111-00			0.1 μ F	Cer	50 V
C139	283-0111-00			0.1 μ F	Cer	50 V
C144	283-0111-00			0.1 μ F	Cer	50 V
C155	283-0111-00			0.1 μ F	Cer	50 V
C157	285-0913-00			3 μ F	PTM	50 V
C158	283-0197-00			470 pF	Cer	50 V
C161	281-0504-00			10 pF	Cer	500 V
C164	283-0111-00			0.1 μ F	Cer	50 V
C166	281-0524-00			150 pF	Cer	500 V
C178	281-0524-00			150 pF	Cer	500 V
C184	281-0524-00			150 pF	Cer	500 V
C189	283-0111-00			0.1 pF	Cer	50 V
C192	281-0623-00			650 pF	Cer	500 V
C193	281-0524-00			150 pF	Cer	500 V
C195	281-0525-00			470 pF	Cer	500 V
C199	281-0523-00			100 pF	Cer	350 V
C200	283-0605-00			678 pF	Mica	300 V
C206	283-0605-00			678 pF	Mica	300 V
C208	283-0111-00			0.1 μ F	Cer	50 V
C218	283-0111-00			0.1 μ F	Cer	50 V
C220	283-0111-00			0.1 μ F	Cer	50 V
C319	283-0065-00			0.001 μ F	Cer	100 V
C320	283-0077-00			330 pF	Cer	500 V
C329	285-0808-00			0.1 μ F	PTM	50 V
C332	290-0340-00			10 μ F	Elect.	50 V
C333	283-0065-00			0.001 μ F	Cer	100 V
C335	283-0110-00			0.005 μ F	Cer	150 V
C349	290-0340-00	B010100	B010134	10 μ F	Elect.	50 V
C349	290-0415-00	B010135		5.6 μ F	Elect.	35 V
C419	290-0158-00			50 μ F	Elect.	25 V

DIGITAL MULTIMETER Circuit Board Assembly (cont)

Ckt. No.	Tektronix Part No.	Serial/Model No. Eff	Disc	Description		
Capacitors (cont)						
C424	283-0111-00		0.1 μ F	Cer	50 V	
C426	290-0135-00		15 μ F	Elect.	20 V	
C427	290-0135-00		15 μ F	Elect.	20 V	
C431	283-0177-00		1 μ F	Cer	25 V	+80%—20%
C434	283-0111-00		0.1 μ F	Cer	50 V	
C435	283-0177-00		1 μ F	Cer	25 V	+80%—20%
C439	283-0111-00		0.1 μ F	Cer	50 V	
C442	290-0297-00		39 μ F	Elect.	10 V	10%
C445	283-0111-00		0.1 μ F	Cer	50 V	
C448	283-0111-00		0.1 μ F	Cer	50 V	
C480	283-0177-00		1 μ F	Cer	25 V	+80%—20%
C482	290-0297-00		39 μ F	Elect.	10 V	10%
C484	283-0177-00		1 μ F	Cer	25 V	+80%—20%

Semiconductor Device, Diodes

CR7	152-0423-00		Silicon	Rectifier	300 V, 3 A	
CR8	152-0423-00		Silicon	Rectifier	300 V, 3 A	
CR13	152-0246-00		Silicon	Low leakage	250 mW, 40 V	
CR14	*152-0107-00		Silicon	Replaceable by	1N647	
CR17	*152-0324-00		Silicon	Tek Spec		
CR20	*152-0324-00		Silicon	Tek Spec		
CR46	*152-0185-00		Silicon	Replaceable by	1N4152	
CR101	*152-0323-00		Silicon	Tek Spec		
CR102	*152-0323-00		Silicon	Tek Spec		
CR119	152-0246-00		Silicon	Low leakage	250 mW, 40 V	
CR130	152-0246-00		Silicon	Low leakage	250 mW, 40 V	
CR142	152-0490-00		FET	1N5286	0.3 mA, \pm 10%	
CR150	152-0245-00		Silicon	High speed		
CR165	*152-0185-00		Silicon	Replaceable by	1N4152	
CR174	*152-0185-00		Silicon	Replaceable by	1N4152	
CR193	*152-0185-00		Silicon	Replaceable by	1N4152	
CR195	*152-0185-00		Silicon	Replaceable by	1N4152	
CR229	*152-0185-00		Silicon	Replaceable by	1N4152	
CR239	*152-0185-00		Silicon	Replaceable by	1N4152	
CR240	*152-0185-00		Silicon	Replaceable by	1N4152	
CR245	*152-0185-00		Silicon	Replaceable by	1N4152	
CR250	*152-0185-00		Silicon	Replaceable by	1N4152	
CR252	*152-0185-00		Silicon	Replaceable by	1N4152	
CR253	*152-0185-00		Silicon	Replaceable by	1N4152	
CR255	*152-0185-00		Silicon	Replaceable by	1N4152	

DIGITAL MULTIMETER Circuit Board Assembly (cont)

Ckt. No.	Tektronix Part No.	Serial/Model No. Eff	Disc	Description
Semiconductor Device, Diodes (cont)				
CR256	*152-0185-00		Silicon	Replaceable by 1N4152
CR267	*152-0185-00		Silicon	Replaceable by 1N4152
CR268	*152-0185-00		Silicon	Replaceable by 1N4152
CR269	*152-0185-00		Silicon	Replaceable by 1N4152
CR278	*152-0185-00		Silicon	Replaceable by 1N4152
CR306	*152-0185-00		Silicon	Replaceable by 1N4152
CR311	*152-0185-00		Silicon	Replaceable by 1N4152
CR408	*152-0185-00		Silicon	Replaceable by 1N4152
CR415	*152-0185-00		Silicon	Replaceable by 1N4152
CR422A,B,C,D(4)	*152-0185-00		Silicon	Replaceable by 1N4152
CR431	*152-0185-00		Silicon	Replaceable by 1N4152
CR435	*152-0185-00		Silicon	Replaceable by 1N4152
CR440A,B,C,D(4)	*152-0185-00		Silicon	Replaceable by 1N4152
CR445	*152-0185-00		Silicon	Replaceable by 1N4152
VR18	152-0309-00		Zener	1N3828A, 1 W, 6.2 V, 5%
VR35	152-0217-00		Zener	1N756A, 400 mW, 8.2 V, 5%
VR47	152-0317-00		Zener	1N3497, 250 mW, 6.2 V, 5%
VR108	152-0127-00		Zener	1N755A, 400 mW, 7.5 V, 5%
VR132	152-0226-00		Zener	1N751A, 400 mW, 5.1 V, 5%
VR139	152-0306-00		Zener	1N960B, 400 mW, 9.1 V, 5%
VR144	152-0486-00		Zener	6.2 V \pm 2%, 0.002% °C TC at 7.5 mA
VR146	152-0226-00		Zener	1N751A, 400 mW, 5.1 V, 5%
VR155	152-0280-00		Zener	1N753A, 400 mW, 6.2 V, 5%
VR164	152-0395-00		Zener	1N749A, 400 mW, 4.3 V, 5%
VR349	152-0317-00		Zener	1N3497, 250 mW, 6.2 V, 5%
VR431	152-0243-00		Zener	1N965B, 400 mW, 15 V, 5%
VR435	152-0243-00		Zener	1N965B, 400 mW, 15 V, 5%
VR445	152-0226-00		Zener	1N751A, 400 mW, 5.1 V, 5%

Fuses

F6	159-0021-00	2 A	3AG	Fast-Blo
F12	159-0024-00	1/16 A	3AG	Fast-Blo

Inductors

L419	*120-0382-00	Toroid, 14 turns, single
L480	*108-0245-00	3.9 μ H
L482	*108-0245-00	3.9 μ H
L484	*108-0245-00	3.9 μ H

DIGITAL MULTIMETER Circuit Board Assembly (cont)

Kct. No.	Tektronix Part No.	Serial/Model No. Eff	Disc	Description
Transistors				
Q24	151-1044-00		Silicon	FET N channel J TO-71 or TO-99, 2N3955 dual
Q28	*151-0192-00		Silicon	NPN TO-92 Replaceable by MPS 6521
Q39	151-1005-00		Silicon	FET N channel, junction type
Q103	151-1047-00		Silicon	FET N channel J TO-71 or TO99, 2N3954, dual
Q105	*151-0192-00		Silicon	NPN TO-92 Replaceable by MPS 6521
Q108	*151-0216-00		Silicon	PNP TO-92 Replaceable by MOT MPS 6523
Q113	151-0188-00		Silicon	PNP TO-92 2N3906
Q125	151-1005-00		Silicon	FET N channel, junction type
Q135	151-1004-00		Silicon	FET N channel, junction type
Q141	151-1004-00		Silicon	FET N channel, junction type
Q149	151-1045-00		Silicon	FET P channel J TO-92 or TO-106, 2N5460
Q152	151-1005-00		Silicon	FET N channel, junction type
Q163	151-0223-00		Silicon	NPN TO-18 2N4275
Q169	151-0223-00		Silicon	NPN TO-18 2N4275
Q173	151-0190-00		Silicon	NPN TO-92 2N3904
Q182	151-0223-00		Silicon	NPN TO-18 2N4275
Q187	151-0224-00		Silicon	NPN TO-18 2N3692
Q190	151-0223-00		Silicon	NPN TO-18 2N4275
Q200	*151-0190-02		Silicon	NPN TO-92 2N3904
Q206	*151-0190-02		Silicon	NPN TO-92 2N3904
Q216	151-0190-00		Silicon	NPN TO-92 2N3904
Q228	151-0190-00		Silicon	NPN TO-92 2N3904
Q232	151-0190-00		Silicon	NPN TO-92 2N3904
Q238	151-0190-00		Silicon	NPN TO-92 2N3904
Q243	151-0190-00		Silicon	NPN TO-92 2N3904
Q248	151-0190-00		Silicon	NPN TO-92 2N3904
Q259	151-0220-00		Silicon	PNP TO-18 2N4122
Q278	151-0190-00		Silicon	NPN TO-92 2N3904
Q301	151-0188-00		Silicon	PNP TO-92 2N3906
Q305	151-0188-00		Silicon	PNP TO-92 2N3906
Q315	151-1022-00		Silicon	FET N channel, J TO-18, 80 Ω , R on
Q326	151-1022-00		Silicon	FET N channel, J TO-18, 80 Ω , R on
Q330	151-1022-00		Silicon	FET N channel, J TO-18, 80 Ω , R on
Q401	151-0224-00		Silicon	NPN TO-18 2N3692
Q408	151-0260-00		Silicon	NPN TO-39 2N5189
Q415	151-0260-00		Silicon	NPN TO-39 2N5189
Q433	151-0190-00		Silicon	NPN TO-92 2N3904
Q438	151-0188-00		Silicon	PNP TO-92 2N3906
Q447	151-0190-00		Silicon	NPN TO-92 2N3904

DIGITAL MULTIMETER Circuit Board Assembly (cont)

Ckt. No.	Tektronix Part No.	Serial/Model No. Eff	Disc	Description
Resistors				
Resistors are fixed, composition, $\pm 10\%$ unless otherwise indicated.				
R10	307-0282-00			1 Ω /0.1 Ω tap 1.5 W 1/10%
R12	301-0510-00			51 Ω 1/2 W 5%
R17	315-0512-00			5.1 k Ω 1/4 W 5%
R20	315-0104-00			100 k Ω 1/4 W 5%
R23	321-0637-00			9.9 k Ω 1/8 W Prec 1/2%
R25	321-0637-00			9.9 k Ω 1/8 W Prec 1/2%
R29	321-0306-00			15 k Ω 1/8 W Prec 1%
R30	315-0152-00			1.5 k Ω 1/4 W 5%
R36	321-0729-06			786 Ω 1/8 W Prec 1/4%
R38	315-0392-00			3.9 k Ω 1/4 W 5%
R40	321-0171-00			590 Ω 1/8 W Prec 1%
R42	321-0766-06			4.053 k Ω 1/8 W Prec 1/4%
R44	311-1060-00	B010100	B010264	500 Ω , Var
R44	311-1177-00	B010265		500 Ω , Var
R47	315-0122-00			1.2 k Ω 1/4 W 5%
R50	315-0682-00			6.8 k Ω 1/4 W 5%
R60	307-1015-00			10,90,900 Ω ; 9,90,900 k Ω , 9 M Ω /tapped, 1500 V
R100	305-0564-00			560 k Ω 2 W 5%
R106	321-0306-00			15 k Ω 1/8 W Prec 1%
R110	315-0132-00			1.3 k Ω 1/4 W 5%
R111	315-0133-00			13 k Ω 1/4 W 5%
R113	315-0391-00			390 Ω 1/4 W 5%
R115	311-0989-00	B010100	B010130	100 Ω , Var
R115	311-1149-00	B010131		50 Ω , Var
R116	321-0289-07			10 k Ω 1/8 W Prec 1/10%
R117	321-0289-07			10 k Ω 1/8 W Prec 1/10%
R120	315-0392-00			3.9 k Ω 1/4 W 5%
R122	321-1289-07			10.1 k Ω 1/8 W Prec 1/10%
R124	315-0510-00			51 Ω 1/4 W 5%
R126	315-0752-00			7.5 k Ω 1/4 W 5%
R128	315-0103-00			10 k Ω 1/4 W 5%
R129	315-0623-00			62 k Ω 1/4 W 5%
R133	315-0103-00			10 k Ω 1/4 W 5%
R134	315-0123-00			12 k Ω 1/4 W 5%
R136	317-0027-00			2.7 Ω 1/8 W 5%
R137	321-0763-07			1.12 k Ω 1/8 W Prec 1/10%
R139	315-0103-00			10 k Ω 1/4 W 5%
R140	315-0123-00			12 k Ω 1/4 W 5%
R144	321-0201-00			1.12 k Ω 1/8 W Prec 1%
R146	315-0202-00			2 k Ω 1/4 W 5%
R148	311-1060-00	B010100	B010264	500 Ω , Var
R148	311-1177-00	B010265		500 Ω , Var
R149	325-0100-00			7.6 k Ω 1/8 W Prec 1%
R153	315-0362-00			3.6 k Ω 1/4 W 5%
R155	315-0302-00			3 k Ω 1/4 W 5%
R158	317-0392-00			3.9 k Ω 1/8 W 5%
R159	315-0102-00			1 k Ω 1/4 W 5%

DIGITAL MULTIMETER Circuit Board Assembly (cont)

Ckt. No.	Tektronix Part No.	Serial/Model No. Eff	Disc	Description		
Resistors (cont)						
R161	315-0153-00			15 k Ω	1/4 W	5%
R163	315-0103-00			10 k Ω	1/4 W	5%
R164	315-0203-00			20 k Ω	1/4 W	5%
R166	315-0681-00			680 Ω	1/4 W	5%
R167	315-0681-00			680 Ω	1/4 W	5%
R168	315-0152-00			1.5 k Ω	1/4 W	5%
R169	315-0102-00			1 k Ω	1/4 W	5%
R171	315-0512-00			5.1 k Ω	1/4 W	5%
R173	315-0512-00			5.1 k Ω	1/4 W	5%
R176	315-0102-00			1 k Ω	1/4 W	5%
R178	315-0681-00			680 Ω	1/4 W	5%
R179	315-0681-00			680 Ω	1/4 W	5%
R180	315-0152-00			1.5 k Ω	1/4 W	5%
R182	315-0202-00			2 k Ω	1/4 W	5%
R184	315-0681-00			680 Ω	1/4 W	5%
R185	315-0681-00			680 Ω	1/4 W	5%
R186	315-0152-00			1.5 k Ω	1/4 W	5%
R187	315-0102-00			1 k Ω	1/4 W	5%
R190	315-0202-00			2 k Ω	1/4 W	5%
R192	315-0622-00			6.2 k Ω	1/4 W	5%
R193	315-0122-00			1.2 k Ω	1/4 W	5%
R194	315-0122-00			1.2 k Ω	1/4 W	5%
R195	315-0122-00			1.2 k Ω	1/4 W	5%
R196	315-0122-00			1.2 k Ω	1/4 W	5%
R198	315-0102-00			1 k Ω	1/4 W	5%
R199	315-0622-00			6.2 k Ω	1/4 W	5%
R200	321-0164-00			499 Ω	1/8 W	Prec 1%
R202	321-0303-00	B010100	B010134	14 k Ω	1/8 W	Prec 1%
R202	321-0299-00	B010135		12.7 k Ω	1/8 W	Prec 1%
R203	311-0609-00	B010100	B010134	2 k Ω , Var		
R203	311-0633-00	B010135		5 k Ω , Var		
R205	321-0301-00			13.3 k Ω	1/8 W	Prec 1%
R206	321-0164-00			499 Ω	1/8 W	Prec 1%
R209	315-0202-00			2 k Ω	1/4 W	5%
R216	315-0102-00			1 k Ω	1/4 W	5%
R224	315-0102-00			1 k Ω	1/4 W	5%
R226	315-0562-00			5.6 k Ω	1/4 W	5%
R227	315-0104-00			100 k Ω	1/4 W	5%
R230	315-0562-00			5.6 k Ω	1/4 W	5%
R231	315-0104-00			100 k Ω	1/4 W	5%
R234	315-0153-00			15 Ω	1/4 W	5%
R236	315-0562-00			5.6 k Ω	1/4 W	5%
R237	315-0104-00			100 k Ω	1/4 W	5%
R239	315-0153-00			15 k Ω	1/4 W	5%
R240	315-0473-00			47 k Ω	1/4 W	5%

DIGITAL MULTIMETER Circuit Board Assembly (cont)

Ckt. No.	Tektronix Part No.	Serial/Model No. Eff	Disc	Description		
Resistors (cont)						
R241	315-0223-00		22 k Ω	1/4 W		5%
R243	315-0273-00		27 k Ω	1/4 W		5%
R245	315-0473-00		47 k Ω	1/4 W		5%
R246	315-0223-00		22 k Ω	1/4 W		5%
R248	315-0273-00		27 k Ω	1/4 W		5%
R256	315-0562-00		5.6 k Ω	1/4 W		5%
R257	315-0912-00		9.1 k Ω	1/4 W		5%
R262	315-0102-00		1 k Ω	1/4 W		5%
R264	315-0163-00		16 k Ω	1/4 W		5%
R265	321-0311-00		16.9 k Ω	1/8 W	Prec	1%
R266	321-0340-00		34 k Ω	1/8 W	Prec	1%
R267	321-0369-00		68.1 k Ω	1/8 W	Prec	1%
R268	321-0398-00		137 k Ω	1/8 W	Prec	1%
R269	321-0395-00		127 k Ω	1/8 W	Prec	1%
R270	321-0327-00		24.9 k Ω	1/8 W	Prec	1%
R271	321-0344-00		37.4 k Ω	1/8 W	Prec	1%
R272	321-0335-00		30.1 k Ω	1/8 W	Prec	1%
R273	321-0327-00		24.9 k Ω	1/8 W	Prec	1%
R275	315-0154-00		150 k Ω	1/4 W		5%
R276	321-0335-00		30.1 k Ω	1/8 W	Prec	1%
R277	315-0154-00		150 k Ω	1/4 W		5%
R278	315-0104-00		100 k Ω	1/4 W		5%
R279	315-0562-00		5.6 k Ω	1/4 W		5%
R281	321-0356-00		49.9 k Ω	1/8 W	Prec	1%
R282	315-0154-00		150 k Ω	1/4 W		5%
R284	321-0356-00		49.9 k Ω	1/8 W	Prec	1%
R285	321-0327-00		24.9 k Ω	1/8 W	Prec	1%
R287	321-0344-00		37.4 k Ω	1/8 W	Prec	1%
R288	315-0753-00		75 k Ω	1/4 W		5%
R290	315-0154-00		150 k Ω	1/4 W		5%
R291	321-0315-00		18.7 k Ω	1/8 W	Prec	1%
R293	321-0356-00		49.9 k Ω	1/8 W	Prec	1%
R294	321-0310-00		16.5 k Ω	1/8 W	Prec	1%
R296	321-0344-00		37.4 k Ω	1/8 W	Prec	1%
R302	315-0392-00		3.9 k Ω	1/4 W		5%
R304	315-0272-00		2.7 k Ω	1/4 W		5%
R306	315-0392-00		3.9 k Ω	1/4 W		5%
R308	315-0273-00		27 k Ω	1/4 W		5%
R309	315-0222-00		2.2 k Ω	1/4 W		5%
R311	315-0103-00		10 k Ω	1/4 W		5%
R315	321-0365-09		61.9 k Ω	1/8 W	Prec	1%
R317	322-0643-00		600 k Ω	1/4 W	Prec	1%
R320	321-0222-09		2 k Ω	1/8 W	Prec	1%
R322	321-0116-09		158 Ω	1/8 W	Prec	1%
R325	315-0104-00		100 k Ω	1/4 W		5%

DIGITAL MULTIMETER Circuit Board Assembly (cont)

Ckt. No.	Tektronix Part No.	Serial/Model No. Eff	No. Disc	Description		
Resistors (cont)						
R331	315-0104-00		100 k Ω	1/4 W		5%
R333	315-0683-00		68 k Ω	1/4 W		5%
R336	321-0222-00		2 k Ω	1/8 W	Prec	1%
R337	311-0605-00		200 Ω , Var			
R339	321-0423-09		249 k Ω	1/8 W	Prec	1%
R341	321-0397-09		133 k Ω	1/8 W	Prec	1%
R343	321-0446-09		432 k Ω	1/8 W	Prec	1%
R345	321-0174-00		634 Ω	1/8 W	Prec	1%
R346	311-1175-00		100 Ω , Var			
R347	321-0190-09		931 Ω	1/8 W	Prec	1%
R401	315-0102-00		1 k Ω	1/4 W		5%
R403	315-0153-00		15 k Ω	1/4 W		5%
R404	315-0561-00		560 Ω	1/4 W		5%
R413	315-0682-00		6.8 k Ω	1/4 W		5%
R430	315-0151-00		150 Ω	1/4 W		5%
R433	315-0120-00		12 Ω	1/4 W		5%
R436	315-0151-00		150 Ω	1/4 W		5%
R438	315-0120-00		12 Ω	1/4 W		5%
R444	315-0201-00		200 Ω	1/4 W		5%
R447	315-0150-00		15 Ω	1/4 W		5%
R480	315-0100-00		10 Ω	1/4 W		5%

Transformers

T168	*120-0697-00	Toroid, two 20 turn windings
T179	*120-0697-00	Toroid, two 20 turn windings
T185	*120-0697-00	Toroid, two 20 turn windings
T420	*120-0698-00	Pot Core

Integrated Circuits

U32	156-0067-00	Op ampl. Replaceable by Fairchild μ A741C
U45	156-0067-00	Op ampl. Replaceable by Fairchild μ A741C
U118	156-0067-00	Op ampl. Replaceable by Fairchild μ A741C
U128	156-0067-00	Op ampl. Replaceable by Fairchild μ A741C
U145	156-0067-00	Op ampl. Replaceable by Fairchild μ A741C
U155	156-0067-00	Op ampl. Replaceable by Fairchild μ A741C
U158	156-0096-00	Voltage comparator, linear. Replaceable by LM 311
U159	156-0030-00	Quad 2-input gate. Replaceable by T.I. SN7400N
U189	156-0039-00	Dual J-K flip-flop. Replaceable by T.I. SN7473N
U195	156-0043-00	Quad 2-input NOR gate. Replaceable by SN7402N

DIGITAL MULTIMETER Circuit Board Assembly (cont)

Ckt. No.	Tektronix Part No.	Serial/Model No. Eff	Disc	Description
Integrated Circuits (cont)				
U208	156-0032-00			4-bit binary counter. Replaceable by T.I. SN7493N
U210	156-0079-00			Decade counter. Replaceable by T.I. SN7490N
U212	156-0079-00			Decade counter. Replaceable by T.I. SN7490N
U214	156-0079-00			Decade counter. Replaceable by T.I. SN7490N
U218	156-0040-00			Quad latch. Replaceable by T.I. SN7475N
U220	156-0040-00			Quad latch. Replaceable by T.I. SN7475N
U222	156-0040-00			Quad latch. Replaceable by T.I. SN7475N
U224	156-0041-00			Dual D flip-flop. Replaceable by T.I. SN7474N
U260	156-0098-00			Dual 4-line to 1-line data selector w/strobe. Replaceable by T.I. SN74153N
U262	156-0098-00			Dual 4-line to 1-line data selector w/strobe. Replaceable by T.I. SN74153N
U264	*155-0038-01			D-A converter.
U319	*156-0067-02			Op ampl. Replaceable by Fairchild μ A741C, selected
U335	*156-0067-02			Op ampl. Replaceable by Fairchild μ A741C, selected

<http://www.ebaman.com>

SECTION 7

DIAGRAMS AND CIRCUIT BOARD ILLUSTRATIONS

Symbols and Reference Designators

Electrical components shown on the diagrams are in the following units unless noted otherwise:

Capacitors =	Values one or greater are in picofarads (pF). Values less than one are in microfarads (μ F).
Resistors =	Ohms (Ω)

Symbols used on the diagrams are based on USA Standard Y32.2-1967.

Logic symbology is based on MIL-STD-806B in terms of positive logic. Logic symbols depict the logic function performed and may differ from the manufacturer's data.

The following special symbols are used on the diagrams:

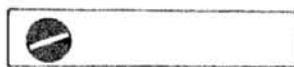

External Screwdriver adjustment.

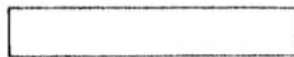

External control or connector.



Refer to diagram number indicated in diamond.



Refer to waveform number indicated in hexagon.

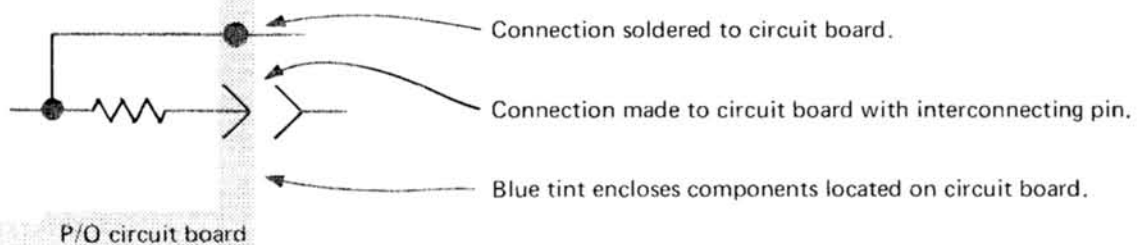

The following prefix letters are used as reference designators to identify components or assemblies on the diagrams.

A	Assembly, separable or repairable (circuit board, etc.)	LR	Inductor/resistor combination
AT	Attenuator, fixed or variable	M	Meter
B	Motor	Q	Transistor or silicon-controlled rectifier
BT	Battery	P	Connector, movable portion
C	Capacitor, fixed or variable	R	Resistor, fixed or variable
CR	Diode, signal or rectifier	RT	Thermistor
DL	Delay line	S	Switch
DS	Indicating device (lamp)	T	Transformer
F	Fuse	TP	Test point
FL	Filter	U	Assembly, inseparable or non-repairable (integrated circuit, etc.)
H	Heat dissipating device (heat sink, heat radiator, etc.)	V	Electron tube
HR	Heater	VR	Voltage regulator (zener diode, etc.)
J	Connector, stationary portion	Y	Crystal
K	Relay		
L	Inductor, fixed or variable		

VOLTAGE AND WAVEFORM TEST CONDITIONS

Typical voltage measurements were obtained under the following conditions unless noted otherwise on the individual diagrams:

Voltmeter

Type	Non-loading digital multimeter
Input Impedance	10 M Ω on all ranges
Range	0 to 1000 volts
Recommended type (as used for voltages on diagrams)	Tektronix 7D13 Digital Multimeter

7D13 (B Horizontal compartment)

MODE/RANGE	DC VOLTS/2 V
INPUT	No input for voltage measurements, COM INPUT connector connected to 7704 ground post connector. 40 mV from oscilloscope Calibrator applied to INPUT connectors for waveforms.

7A16 (right vertical compartment using a 10X probe with readout coding ring. P6053 probe used for waveforms on diagrams)

Polarity	+UP
Bandwidth	Full
Position	Centered
Coupling	AC
Variable	Cal In

7B50 (A horizontal compartment)

Level/Slope	Centered on positive slope
Triggering	
Mode	Norm
Coupling	AC
Source	Ext \div 10
Magnifier	X1
Variable	Cal In
Ext Trig In connector	No connection for voltage measurements. For waveforms, LAST COUNT from TP208 connected to Ext Trig In connector.

7704

Vertical Mode	Right
Horizontal Mode	A
A Intensity	Optimum
B Intensity	Counterclockwise
Calibrator	
Volts	40 mV
Rate	DC
A Trigger Source	Right Vert

Waveforms shown are actual waveform photographs taken with a Tektronix Oscilloscope Camera System and Projected Graticule. Vertical deflection factor shown on waveform is the actual deflection factor from the probe tip. Voltages and waveforms on the diagrams (shown in blue) are not absolute and may vary between instruments because of component tolerances, internal calibration, or front-panel settings. Readouts are simulated in larger-than-normal type.

NOTE

The spring tension of the pin sockets ensures a good connection between the circuit board and pin. This spring tension may be damaged by using the pin sockets as a connecting point for spring-loaded probe tips, alligator clips, etc.

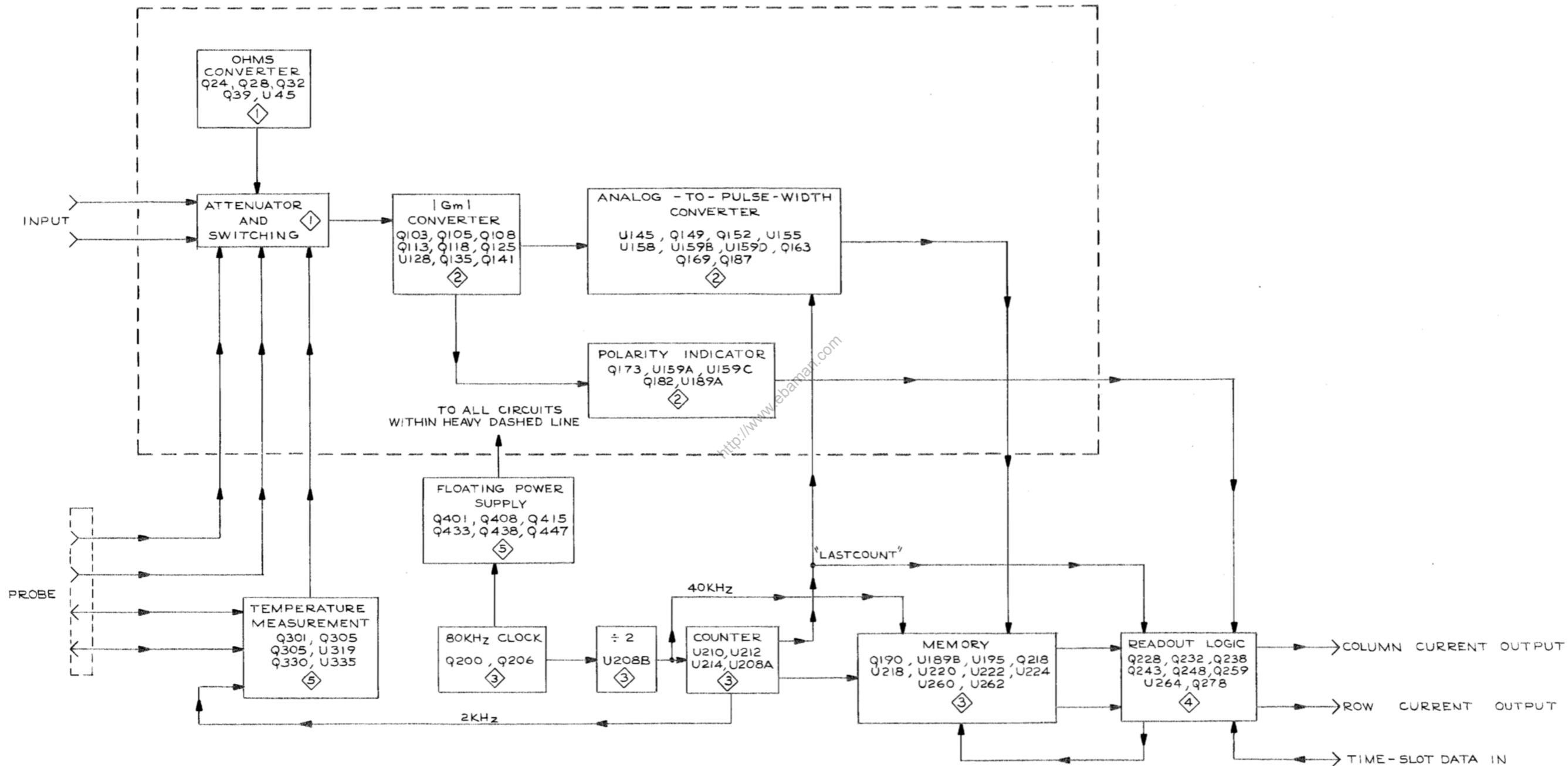

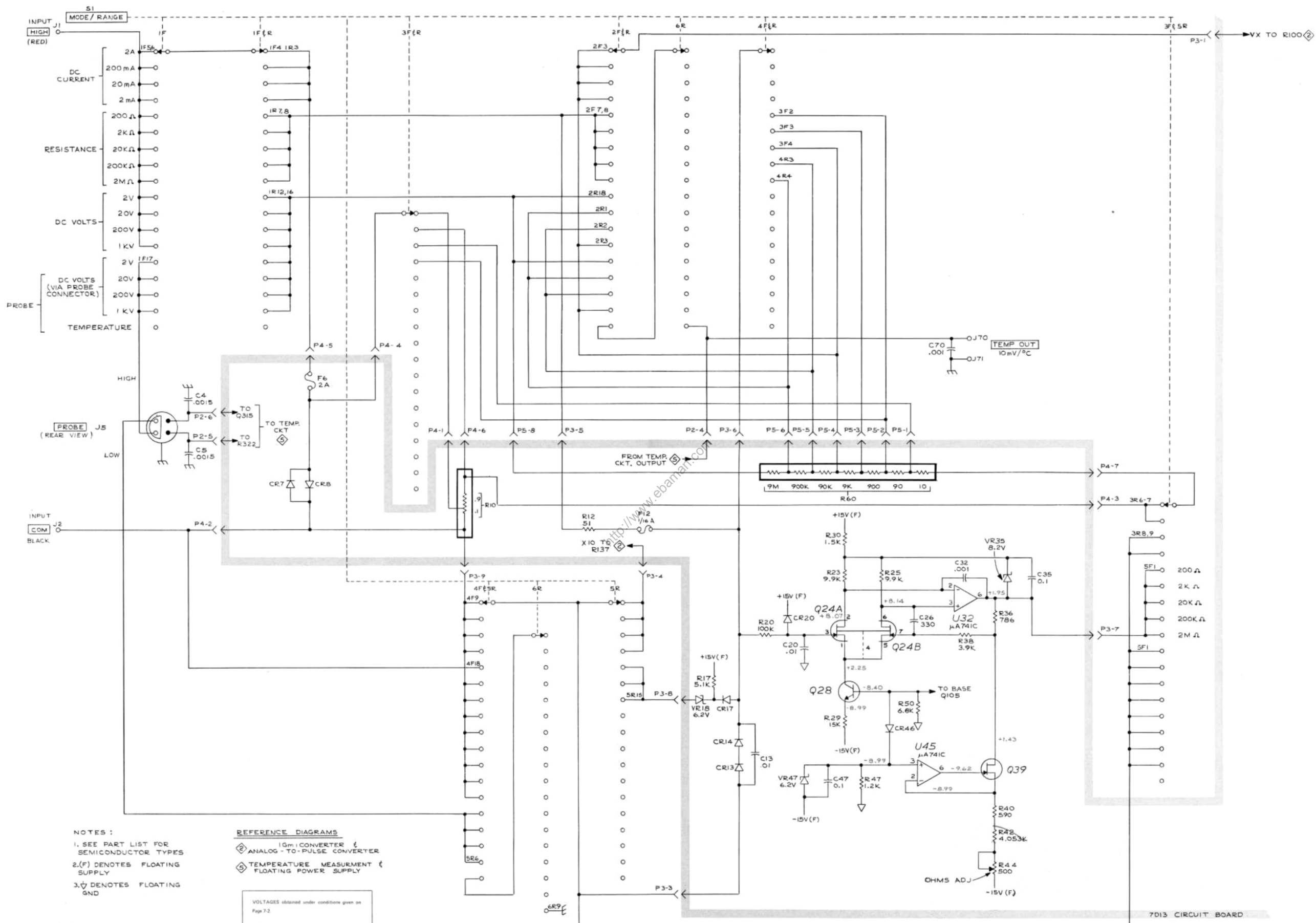

- NOTES :
1. SEE PART LIST FOR SEMICONDUCTOR TYPES
 - 2.(F) DENOTES FLOATING SUPPLY
 - 3.∅ DENOTES FLOATING GND

REFERENCE DIAGRAMS

- ⊠ IGM1 CONVERTER & ANALOG-TO-PULSE CONVERTER
- ⊠ TEMPERATURE MEASUREMENT & FLOATING POWER SUPPLY

VOLTAGES obtained under conditions given on Page 7-2.

VOLTAGES on this diagram are referenced to TP422, floating power supply GND.

1

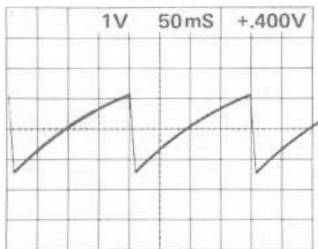

2

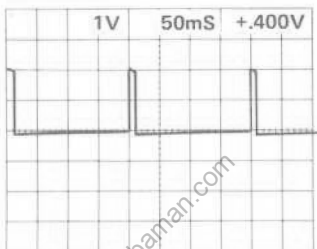

3

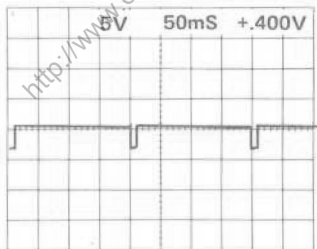

4

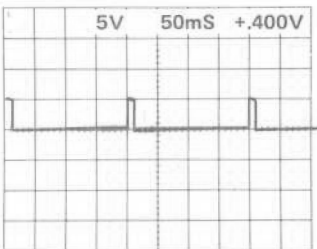

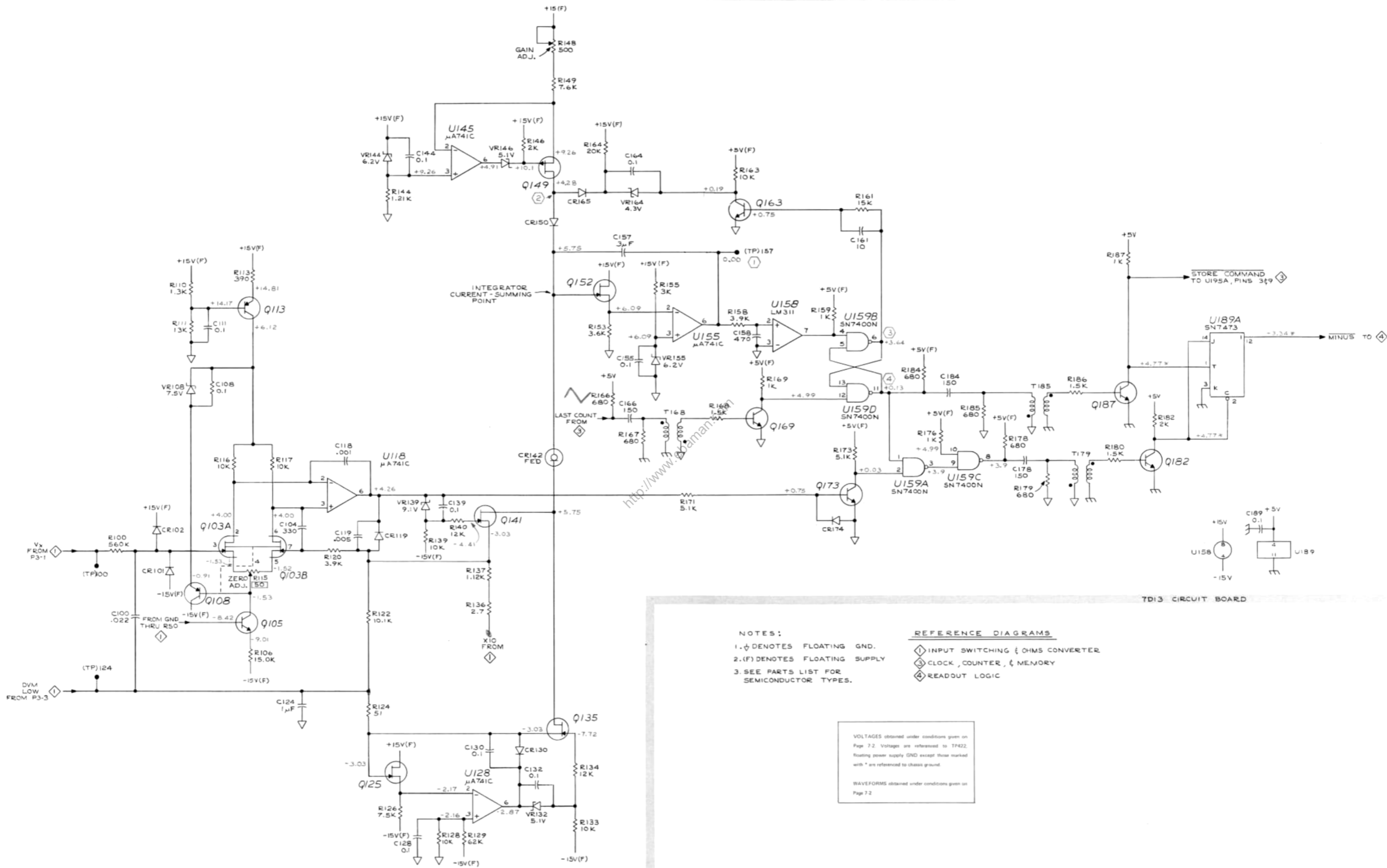

TD13 CIRCUIT BOARD

NOTES:

- 1. ϕ DENOTES FLOATING GND.
- 2. (F) DENOTES FLOATING SUPPLY
- 3. SEE PARTS LIST FOR SEMICONDUCTOR TYPES.

REFERENCE DIAGRAM

- \diamond INPUT SWITCHING & OHMS CONVERTER
- \circ CLOCK, COUNTER, & MEMORY
- \square READOUT LOGIC

VOLTAGES obtained under conditions given on Page 72. Voltages are referenced to TP422, floating power supply GND except those marked with * are referenced to chassis ground.

WAVEFORMS obtained under conditions given on Page 72

1

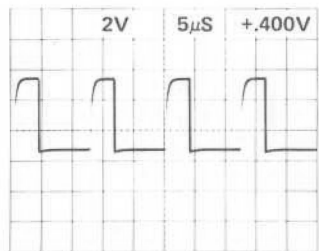

2

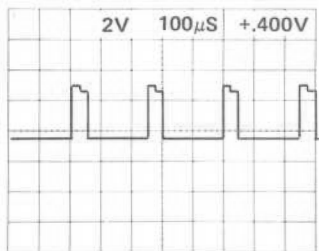

3

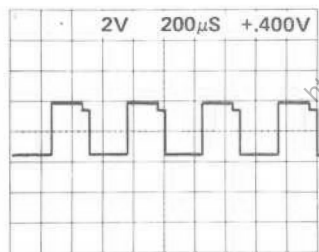

4

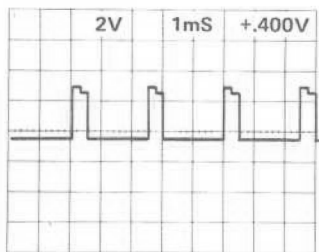

5

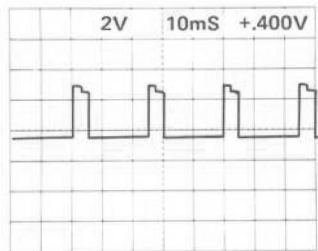

6

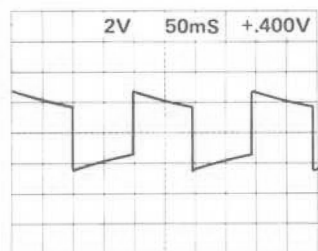

7

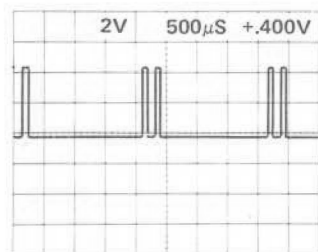

8

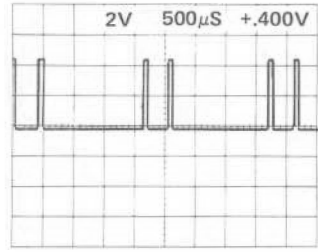

<http://www.ebaman.com>

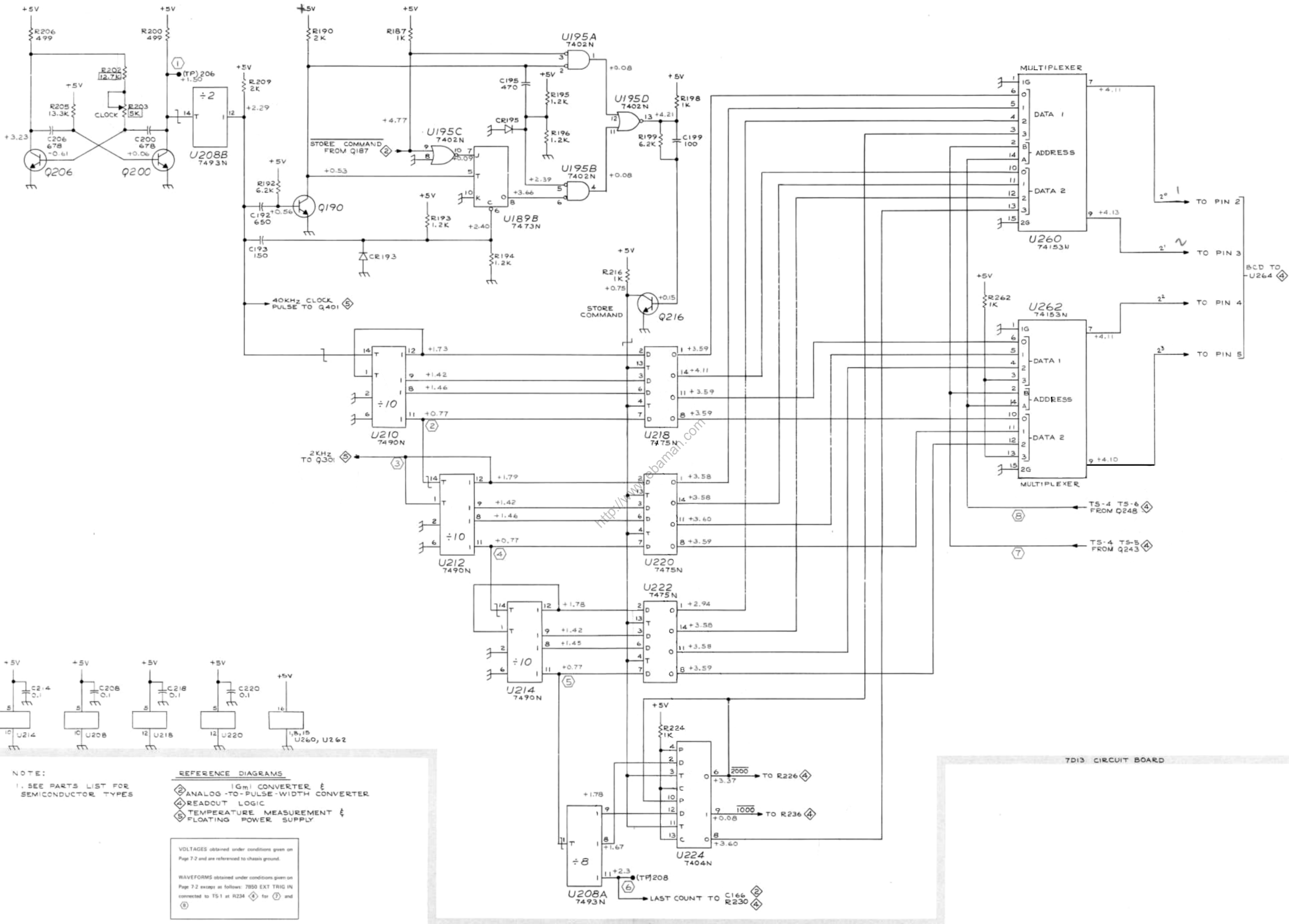

NOTE:
1. SEE PARTS LIST FOR SEMICONDUCTOR TYPES

- REFERENCE DIAGRAMS
- ⊕ 1GmI CONVERTER & ANALOG TO-PULSE-WIDTH CONVERTER
 - ⊕ READOUT LOGIC
 - ⊕ TEMPERATURE MEASUREMENT & FLOATING POWER SUPPLY

VOLTAGES obtained under conditions given on Page 7.2 and are referenced to chassis ground.

WAVEFORMS obtained under conditions given on Page 7.2 except as follows: 7B50 EXT TRIG IN connected to TS-1 at R234 ⊕ for (7) and (8)

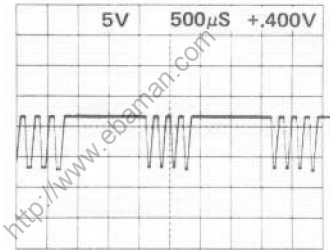

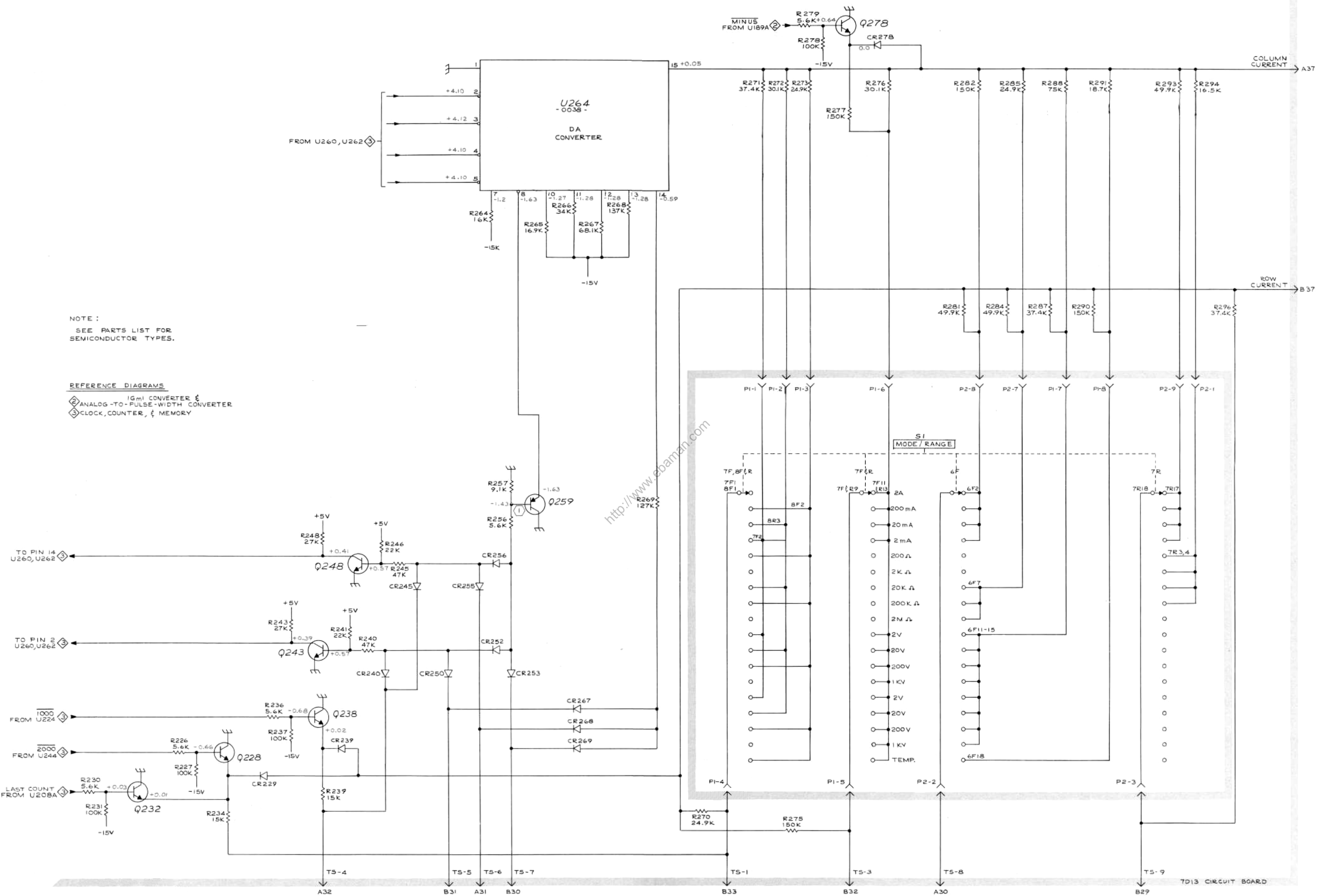

NOTE :
SEE PARTS LIST FOR SEMICONDUCTOR TYPES.

REFERENCE DIAGRAMS
 ◊ Igm CONVERTER &
 ◊ ANALOG-TO-PULSE-WIDTH CONVERTER
 ◊ CLOCK, COUNTER, & MEMORY

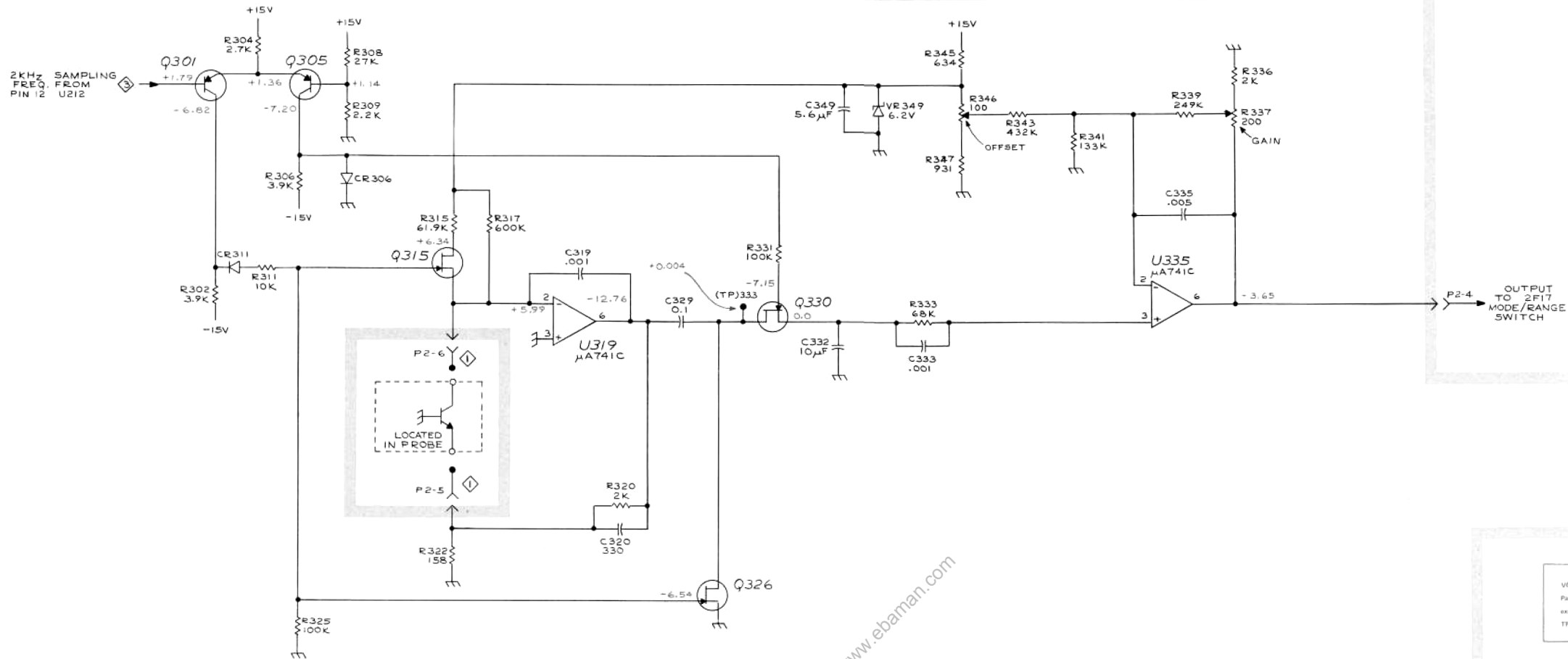

VOLTAGES obtained under conditions given on Page 7-2. Voltages are referenced to chassis ground except those marked with * are referenced to TP422, floating power supply GND.

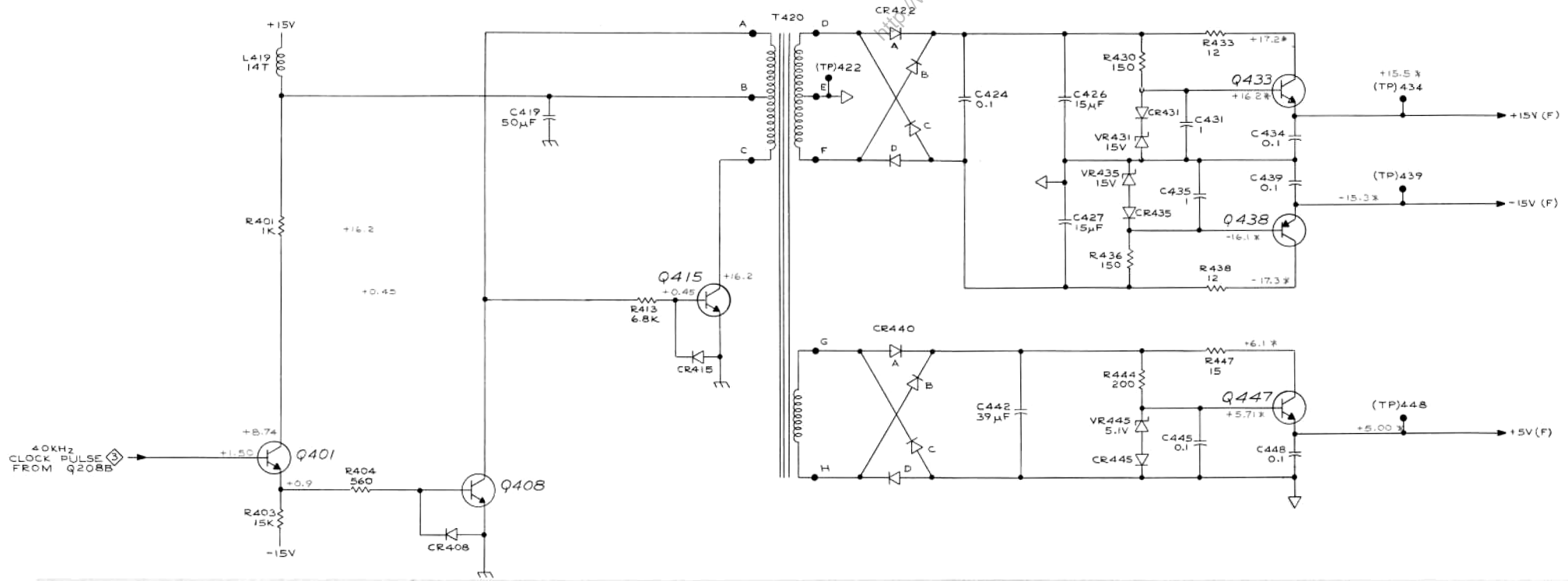

- REFERENCE DIAGRAMS**
- ① INPUT SWITCHING & OHMS CONVERTER
 - ② CLOCK, COUNTER, MEMORY

- NOTES:**
1. SEE PARTS LIST FOR SEMICONDUCTOR TYPES.
 2. ⚡ DENOTES FLOATING GND.
 3. (F) DENOTES FLOATING SUPPLY.

7D13

9 8 7 6 5 4 3 2 ▼
■ ■ ■ ■ ■ ■ ■ ■ ■ ■ P2

8 7 6 5 4 3 2 ▼
■ ■ ■ ■ ■ ■ ■ ■ ■ ■ P1

<http://www.ebaman.com>

9 8 7 6 5 4 3 2 ▼
■ ■ ■ ■ ■ ■ ■ ■ ■ ■ P3

9 8 7 6 5 4 3 2 ▼
P5 ■ ■ ■ ■ ■ ■ ■ ■ ■ ■

7 6 5 4 3 2 ▼
P4 ■ ■ ■ ■ ■ ■ ■ ■ ■ ■

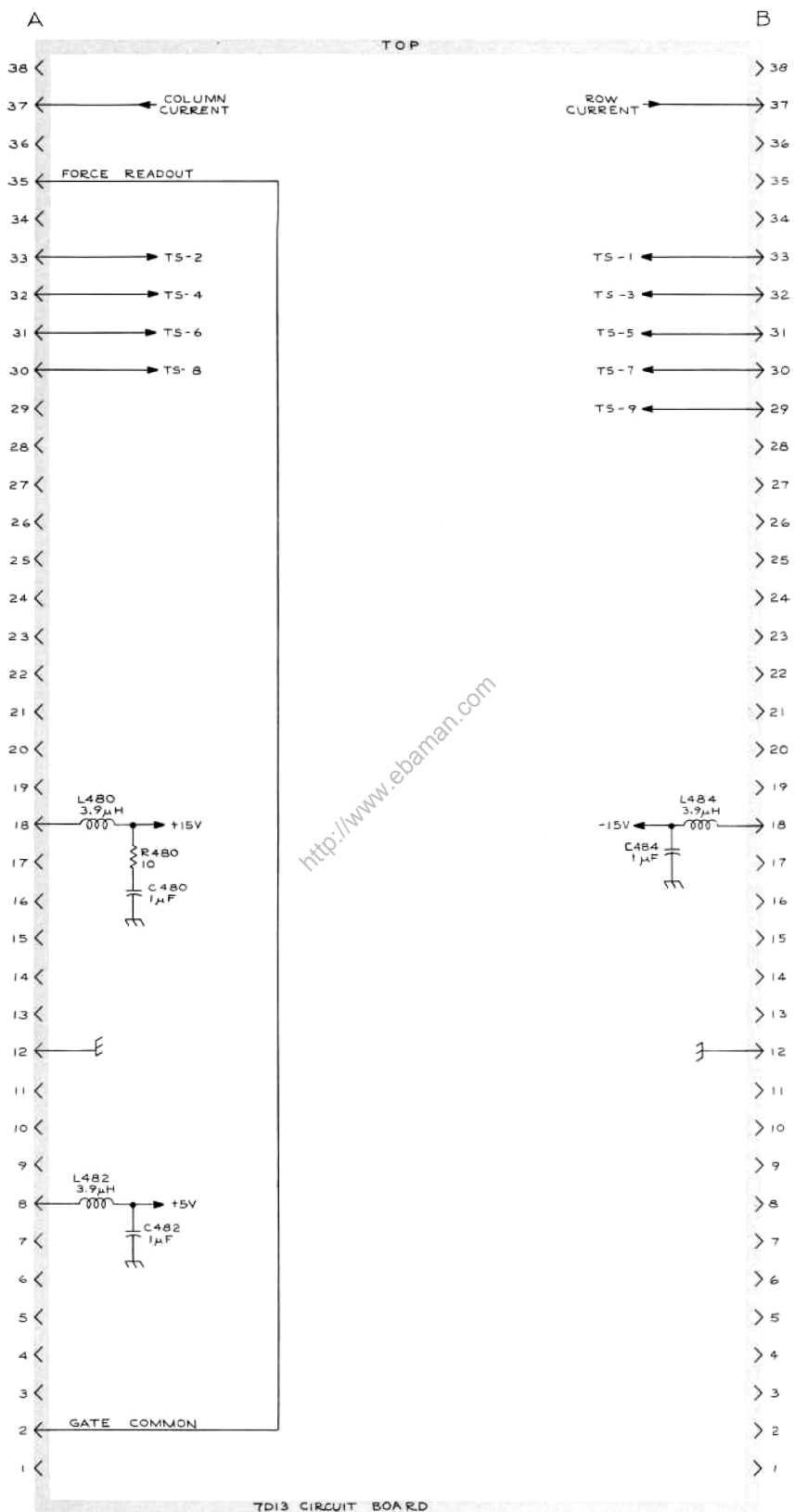

FIGURE AND INDEX NUMBERS

Items in this section are referenced by figure and index numbers to the illustrations which appear either on the back of the diagrams or on pullout pages immediately following the diagrams of the instruction manual.

INDENTATION SYSTEM

This mechanical parts list is indented to indicated item relationships. Following is an example of the indentation system used in the Description column.

Assembly and/or Component
Detail Part of Assembly and/or Component
mounting hardware for Detail Part
Parts of Detail Part
mounting hardware for Parts of Detail Part
mounting hardware for Assembly and/or Component

Mounting hardware always appears in the same indentation as the item it mounts, while the detail parts are indented to the right. Indented items are part of, and included with, the next higher indentation.

Mounting hardware must be purchased separately, unless otherwise specified.

PARTS ORDERING INFORMATION

Replacement parts are available from or through your local Tektronix, Inc. Field Office or representative.

Changes to Tektronix instruments are sometimes made to accommodate improved components as they become available, and to give you the benefit of the latest circuit improvements developed in our engineering department. It is therefore important, when ordering parts, to include the following information in your order: Part number, instrument type or number, serial or model number, and modification number if applicable.

If a part you have ordered has been replaced with a new or improved part, your local Tektronix, Inc. Field Office or representative will contact you concerning any change in part number.

Change information, if any, is located at the rear of this manual.

ABBREVIATIONS AND SYMBOLS

For an explanation of the abbreviations and symbols used in this section, please refer to the page immediately preceding the Electrical Parts List in this instruction manual.

**INDEX OF
MECHANICAL PARTS LIST & ILLUSTRATIONS**

Title	Page Nos. of Parts List
Figure 1 Exploded & Standard Accessories	8-1 thru 8-3
Figure 2 Repackaging	(parts list combined with illustration)

SECTION 8

MECHANICAL PARTS LIST

FIGURE 1 EXPLODED & STANDARD ACCESSORIES

Fig. & Index No.	Tektronix Part No.	Serial/Model No.		Q † y	Description
		Eff	Disc		
1-1	366-1009-00			1	KNOB, gray—MODE/RANGE
	- - - - -			-	knob includes:
	213-0153-00			2	SETSCREW, 5-40 x 0.125 inch, HSS
-2	366-1058-21			1	KNOB, latch
	- - - - -			-	mounting hardware: <i>(not included w/knob)</i>
-3	214-1095-00			1	PIN, spring, split
-4	105-0076-00			1	RELEASE BAR, latch
-5	214-1280-00			1	SPRING, helical compression
-6	214-1054-00			1	SPRING, flat, latch detent
-7	105-0075-00			1	BOLT, latch detent
-8	129-0064-01			1	POST, binding, red
	- - - - -			-	mounting hardware: <i>(not included w/post)</i>
-9	210-0408-00			1	NUT, hex., 6-32 x 0.312 inch
-10	358-0181-01			1	BUSHING, plastic, 0.098 ID x 0.469 inch OD, red
-11	129-0064-00			1	POST, binding, charcoal
	- - - - -			-	mounting hardware: <i>(not included w/post)</i>
-12	210-0408-00			1	NUT, hex., 6-32 x 0.312 inch
-13	358-0181-00			1	BUSHING, plastic, 0.098 ID x 0.469 inch OD, charcoal
-14	131-1011-00			1	CONNECTOR, receptacle, 4 contact, w/hardware
	- - - - -			-	mounting hardware: <i>(not included w/connector)</i>
-15	210-0021-00			1	WASHER, lock, internal, 0.476 ID x 0.60 inch OD
-16	260-1214-00			1	SWITCH, rotary—MODE RANGE, unwired
	- - - - -			-	mounting hardware: <i>(not included w/switch)</i>
-17	210-0590-00			1	NUT, hex., 0.375-32 x 0.438 inch
-18	333-1375-00			1	PANEL, front
-19	136-0387-00			2	JACK, tip, gray
-20	220-0455-00			1	NUT, block, 4-40 x 0.281 inch square
	- - - - -			-	mounting hardware: <i>(not included w/nut)</i>
-21	211-0101-00			1	SCREW, 4-40 x 0.25 inch, 100° csk, FHS

FIGURE 1 EXPLODED & STANDARD ACCESSORIES (cont)

Fig. & Index No.	Tektronix Part No.	Serial/Model No.		Q t Y	Description
		Eff	Disc		
1-22	386-1447-48			1	SUBPANEL, front
	- - - - -			-	mounting hardware: <i>(not included w/subpanel)</i>
-23	213-0192-00			4	SCREW, thread forming, 6-32 x 0.50 inch, Fil HS
-24	214-1061-00			1	SPRING, flat, sliding ground
-25	426-0505-06			1	FRAME SECTION, top
-26	220-0547-01			6	NUT, block, 0.25 x 0.282 x 0.38 inch
	- - - - -			-	mounting hardware for each: <i>(not included w/nut)</i>
-27	211-0105-00			1	SCREW, 4-40 x 0.188 inch, 100° csk, FHS
-28	426-0499-07			1	FRAME SECTION, bottom
-29	386-1402-00			1	PANEL, rear
	- - - - -			-	mounting hardware: <i>(not included w/panel)</i>
-30	213-0192-00			4	SCREW, thread forming, 6-32 x 0.50 inch, Fil HS
-31	361-0326-00			1	SPACER, sleeve, 0.18 ID x 0.25 OD x 0.10 inch long
-32	670-0994-01			1	CIRCUIT BOARD ASSEMBLY—DIGITAL MULTIMETER
	- - - - -			-	circuit board assembly includes:
	388-1826-01			1	CIRCUIT BOARD
-33	131-0589-00			7	TERMINAL, pin, 0.50 inch long
	131-0608-00			32	TERMINAL, pin, 0.365 inch long
-34	136-0183-00			2	SOCKET, transistor, 3 pin
-35	136-0237-00			3	SOCKET, transistor, 8 pin
-36	136-0220-00			35	SOCKET, transistor, 3 pin, square
-37	136-0260-01			70	SOCKET, integrated circuit, 16 pin
-38	136-0269-00			8	SOCKET, integrated circuit, 14 pin
-39	214-0579-00			10	Pin, test point
-40	344-0154-00			4	CLIP, fuse
	- - - - -			-	mounting hardware: <i>not included w/circuit board assembly)</i>
-41	211-0116-00			7	SCREW, sems, 4-40 x 0.312 inch, PHB
-42	210-0201-00			1	LUG, solder, SE #4
	- - - - -			-	mounting hardware: <i>(not included w/lug)</i>
-43	211-0116-00			1	SCREW, sems, 4-40 x 0.312 inch, PHB
-44	210-1002-00			1	WASHER, flat, 0.125 ID x 0.25 inch OD
-45	210-0406-00			1	NUT, hex., 4-40 x 0.188 inch

FIGURE 1 EXPLODED & STANDARD ACCESSORIES (cont)

Fig. & Index No.	Tektronix Part No.	Serial/Model No.		Q † Y	Description
		Eff	Disc		
1-46	179-1624-00			1	WIRING HARNESS, input switching
	- - - - -			-	wiring harness includes:
-47	131-0707-00			15	CONNECTOR, terminal
-48	131-0621-00			7	CONNECTOR, terminal
-49	352-0203-00			1	HOLDER, terminal connector, 7 wire (black)
-50	352-0166-05			1	HOLDER, terminal connector, 8 wire (green)
-51	352-0167-04			1	HOLDER, terminal connector, 9 wire (yellow)
	179-1623-00			1	WIRING HARNESS, logic
	- - - - -			-	wiring harness includes:
	131-0707-00			17	CONNECTOR, terminal
	352-0166-01			1	HOLDER, terminal connector, 8 wire (brown)
	352-0167-02			1	HOLDER, terminal connector, 9 wire (red)
-52	337-1064-00			2	SHIELD, electrical, side, 4.613 x 12.050 inches
-53	348-0235-00			2	SHIELDING GASKET, electrical

STANDARD ACCESSORIES

010-0260-00	1	PROBE PACKAGE, P6058 (not shown)
070-1096-00	1	MANUAL, instruction (not shown)

<http://www.ebaman.com>

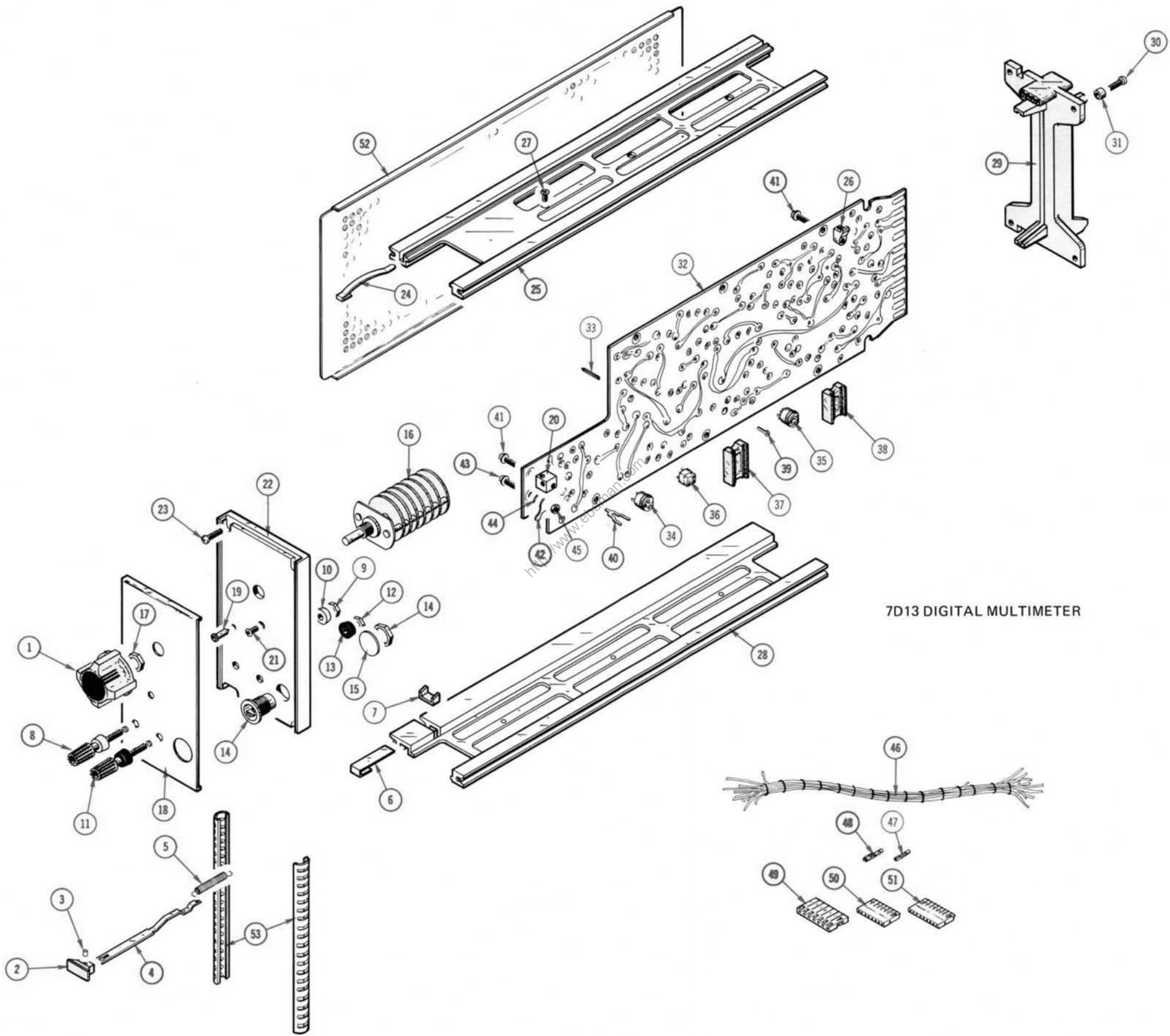

7D13 DIGITAL MULTIMETER

CARTON ASSEMBLY
(Part No. 065-0125-00)

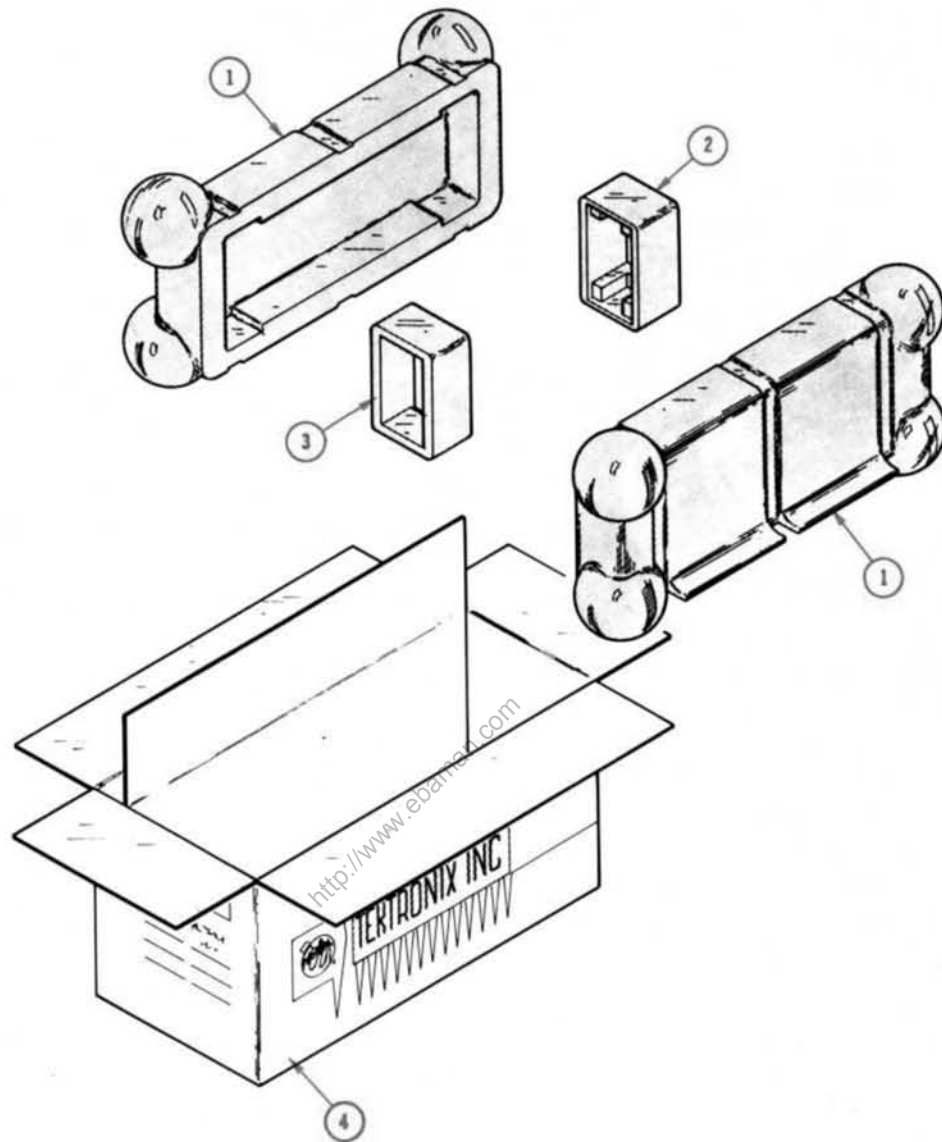

Fig. & Index No.	Tektronix Part No.	Serial/Model No. Eff	Disc	Q t y						Description
					1	2	3	4	5	
	065-0125-00			1						ASSEMBLY, carton
	- - - - -			-						assembly includes:
-1	004-0241-00			2						CASE HALF
-2	004-0242-00			1						END CAP, rear
-3	004-0243-00			1						END CAP, front
-4	004-0748-00			1						CARTON

MANUAL CHANGE INFORMATION

At Tektronix, we continually strive to keep up with latest electronic developments by adding circuit and component improvements to our instruments as soon as they are developed and tested.

Sometimes, due to printing and shipping requirements, we can't get these changes immediately into printed manuals. Hence, your manual may contain new change information on following pages.

A single change may affect several sections. Sections of the manual are often printed at different times, so some of the information on the change pages may already be in your manual. Since the change information sheets are carried in the manual until ALL changes are permanently entered, some duplication may occur. If no such change pages appear in this section, your manual is correct as printed.

<http://www.ebama.com>

STANDARD ACCESSORIES ADDITION

Mechanical Parts List

Page 8-3 Standard Accessories

ADD: the following item to the Standard Accessories List:

003-0120-00

1 METER LEADS, pair (not shown)

<http://www.ebaman.com>

ELECTRICAL PARTS LIST AND SCHEMATIC CORRECTION

DIGITAL MULTIMETER Circuit Board Assembly

CHANGE TO:

670-0994-02	Complete Board
R403 315-0622-00	6.2 k Ω 1/4 W 5%

ADD:

C404 283-0028-00	.0022 Ω F Cer 50 V
R410 315-0682-00	6.8 k Ω 1/4 W 5%

MECHANICAL PARTS LIST CORRECTION

SECTION 8 Page 8-2

CHANGE TO:

-32 670-0994-02	CIRCUIT BOARD ASSEMBLY--DIGITAL MULTIMETER
----------------------	--

<http://www.eban.com>

SCHEMATIC CORRECTION

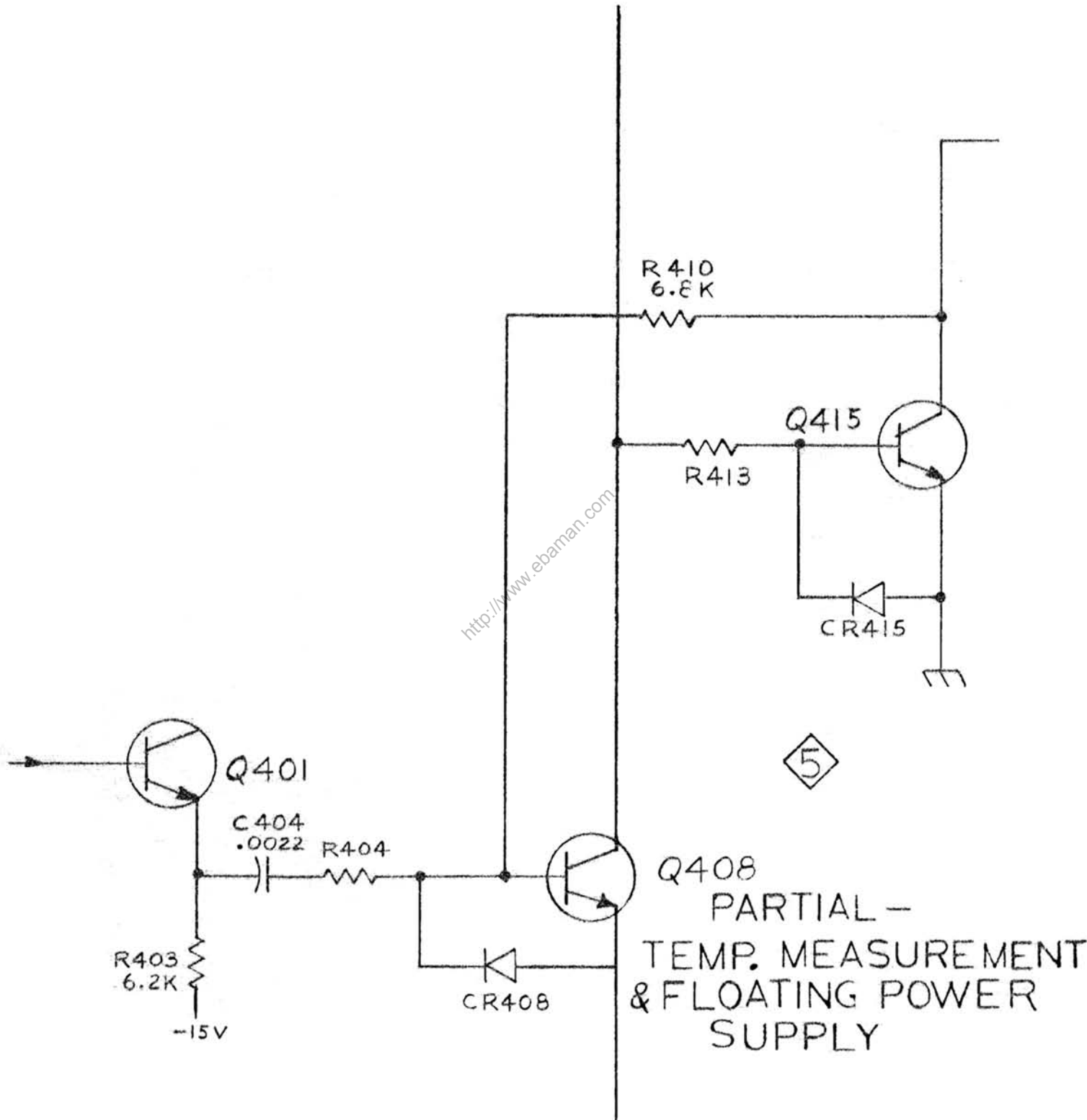

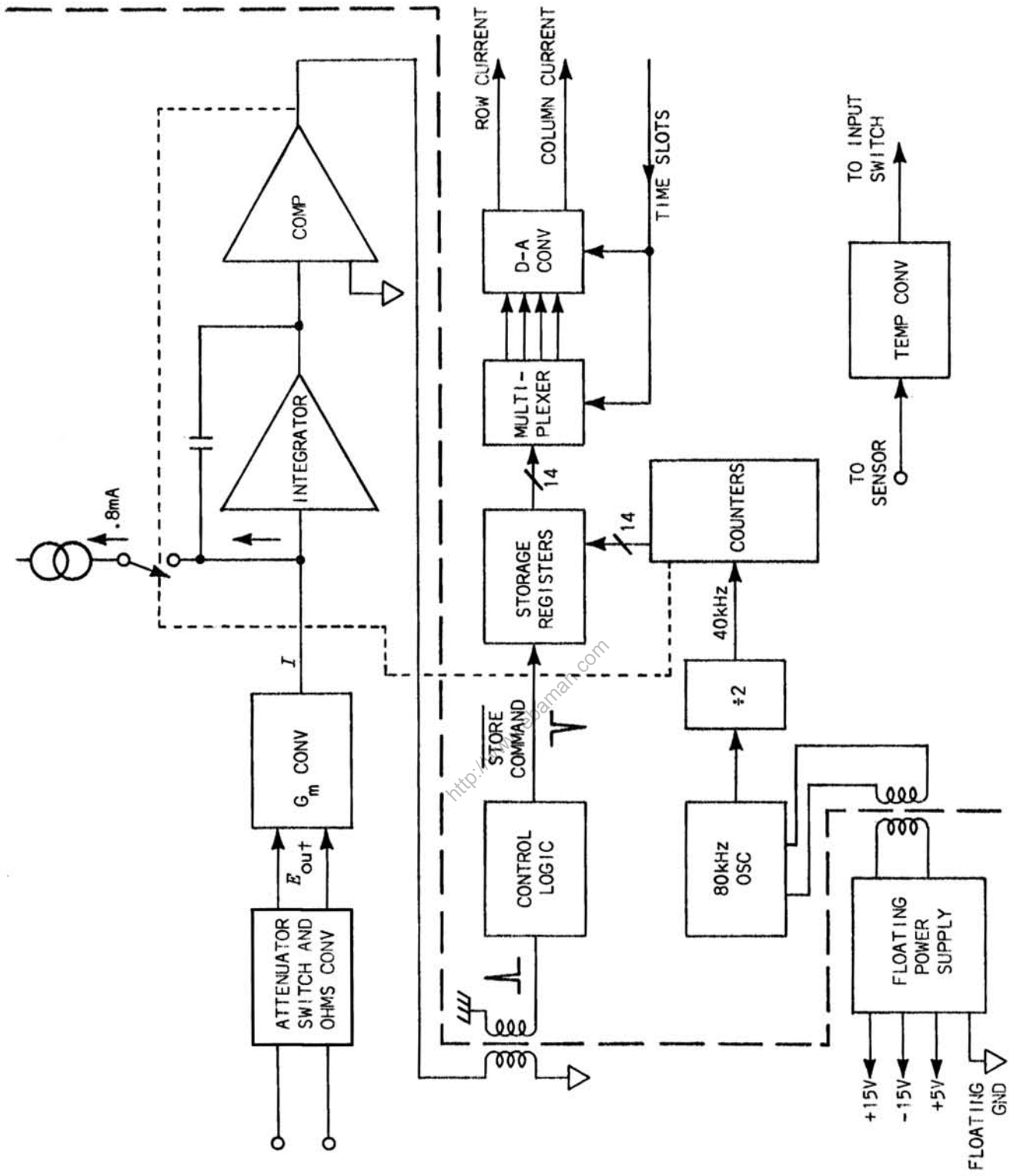

FIGURE 1 - BLOCK DIAGRAM

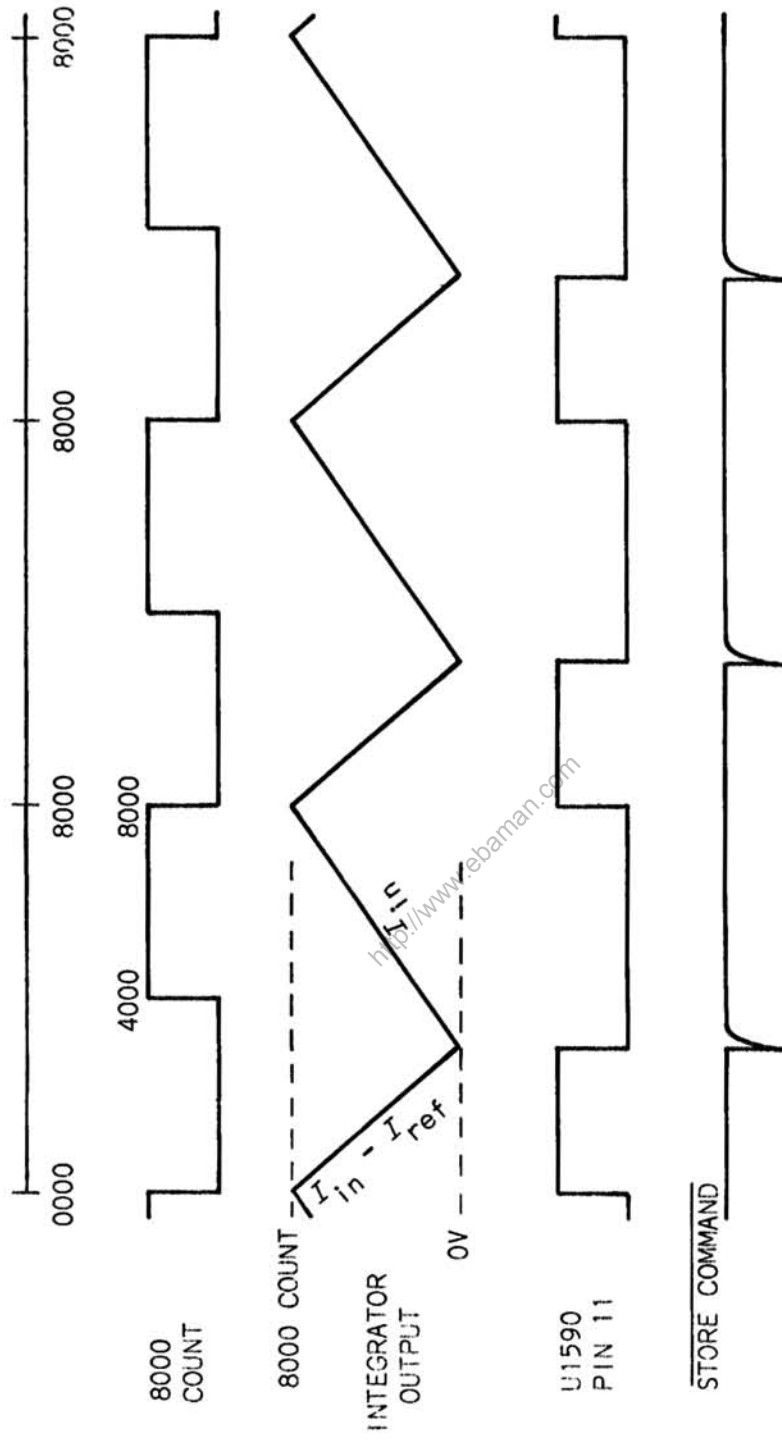

FIGURE 2 - 7D13 TIMING

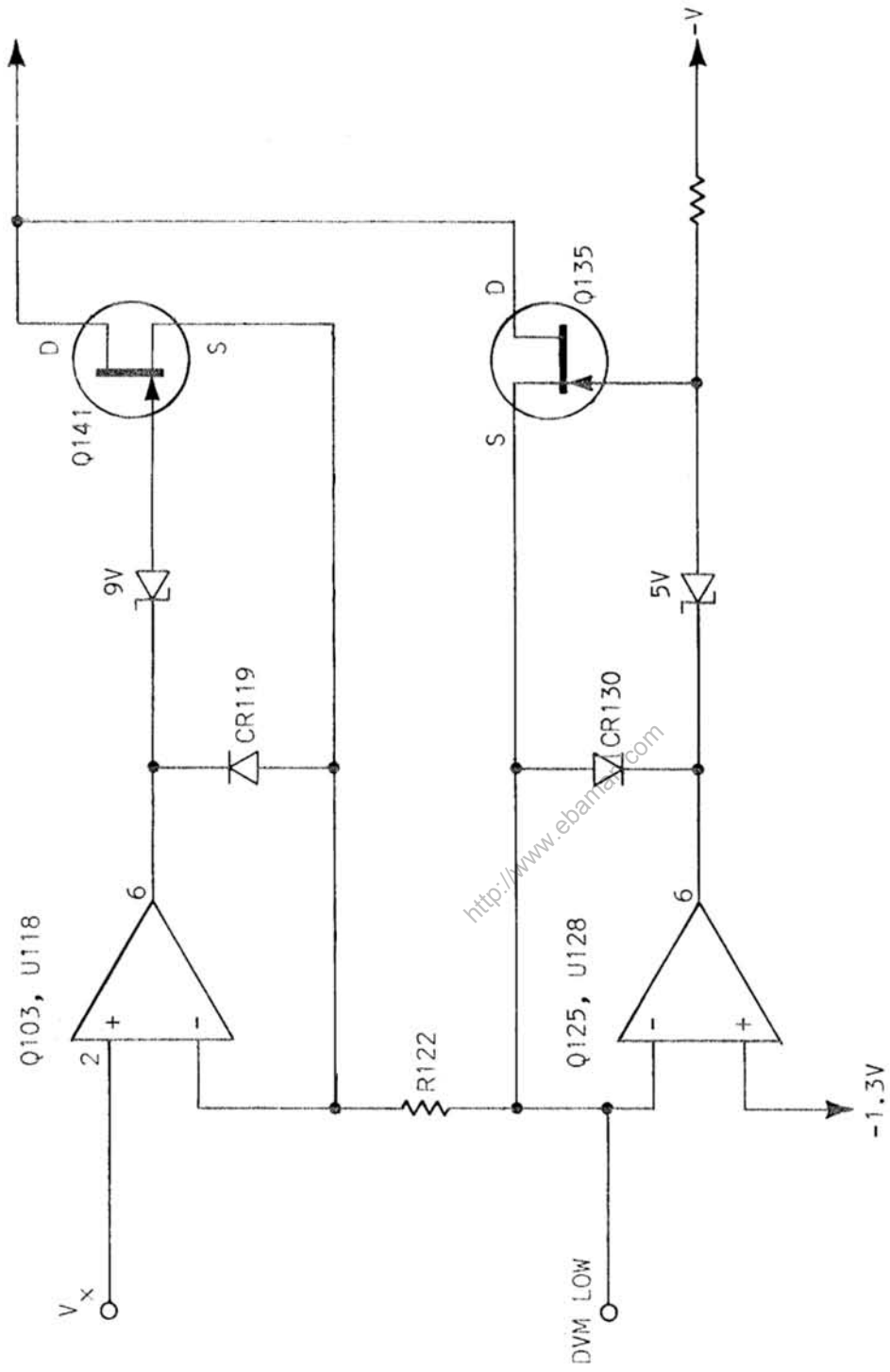
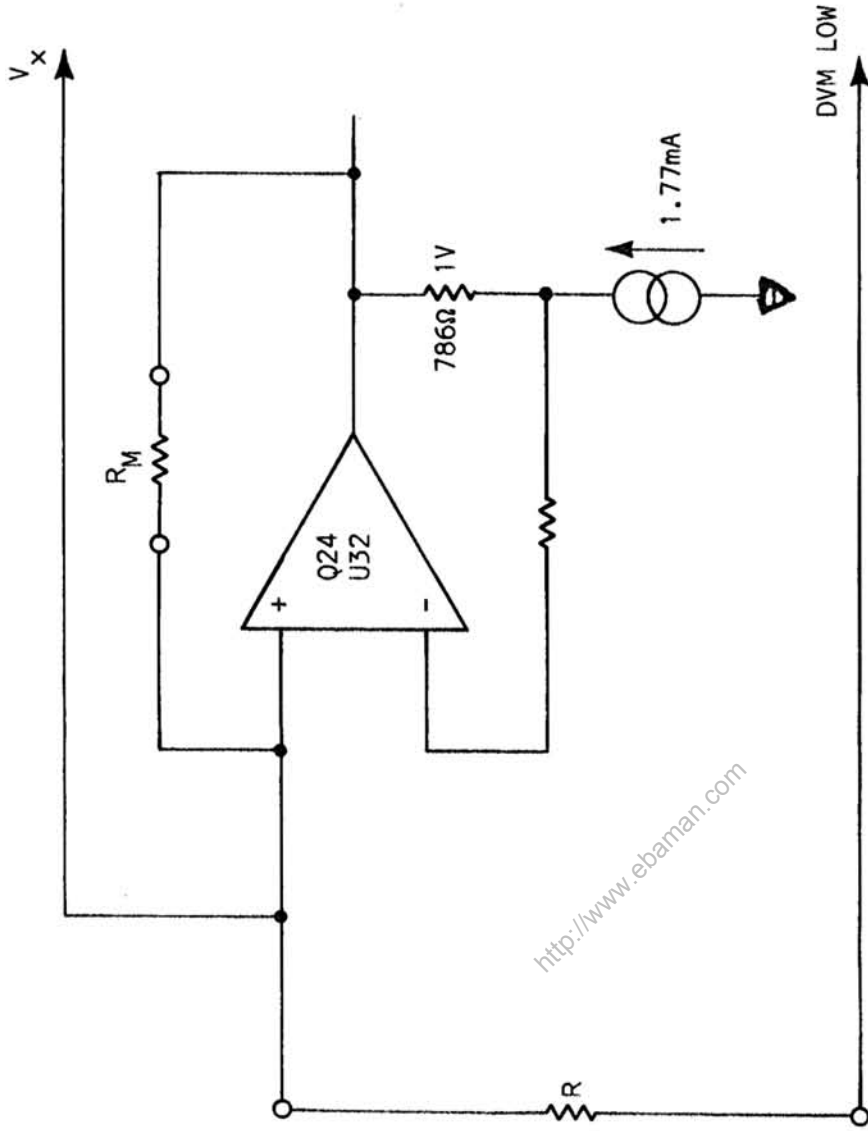

FIGURE 4 - 7D13 G_m CONVERTER

B-7D13-0005



<http://www.ebaman.com>

FIGURE 5 - 7D13 OHMS CONVERTER

B-7D13-0006

(A) (B)
 HH = 1C3
 HL = 1C1
 LH = 1C2
 LL = 1C0

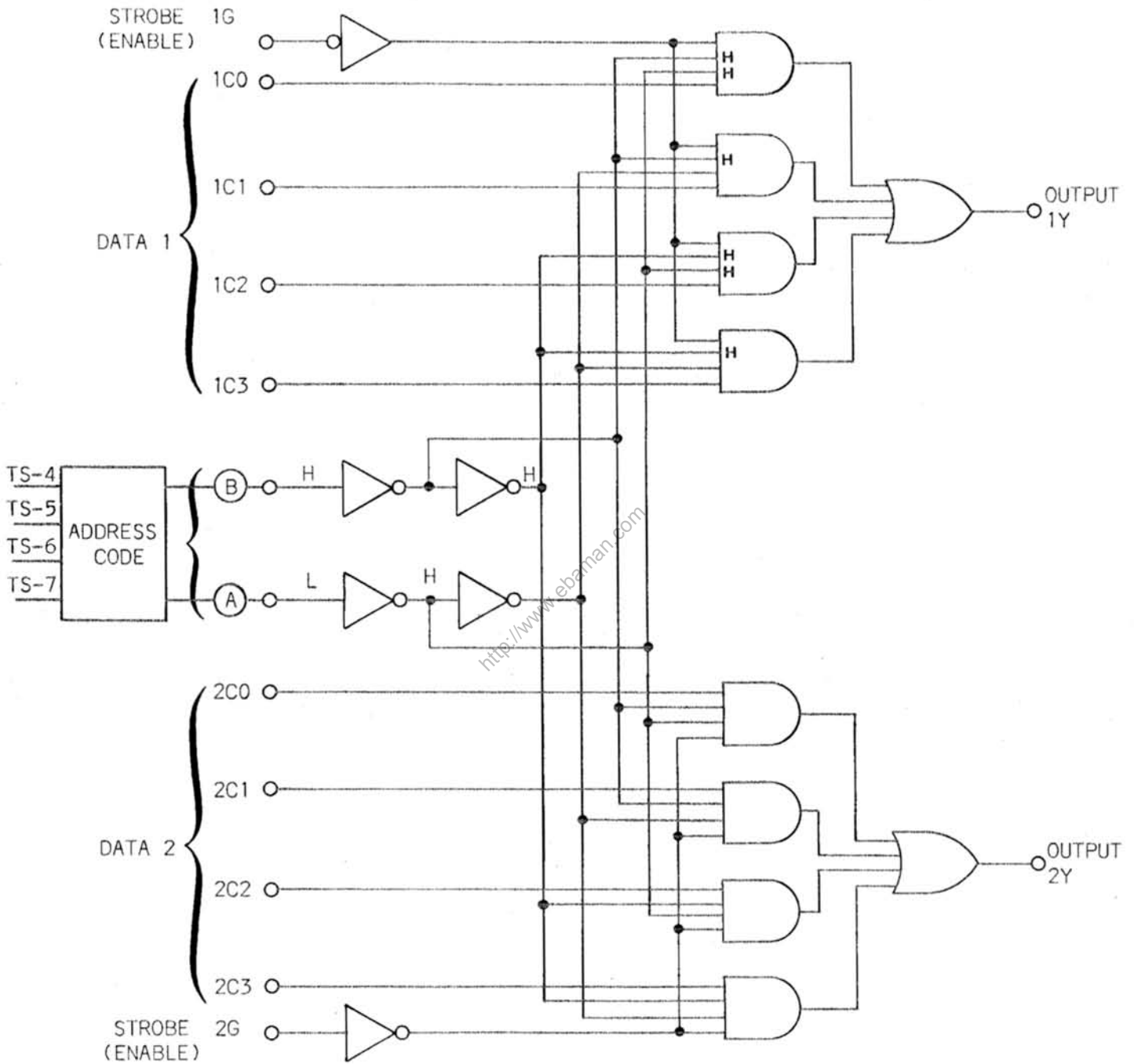
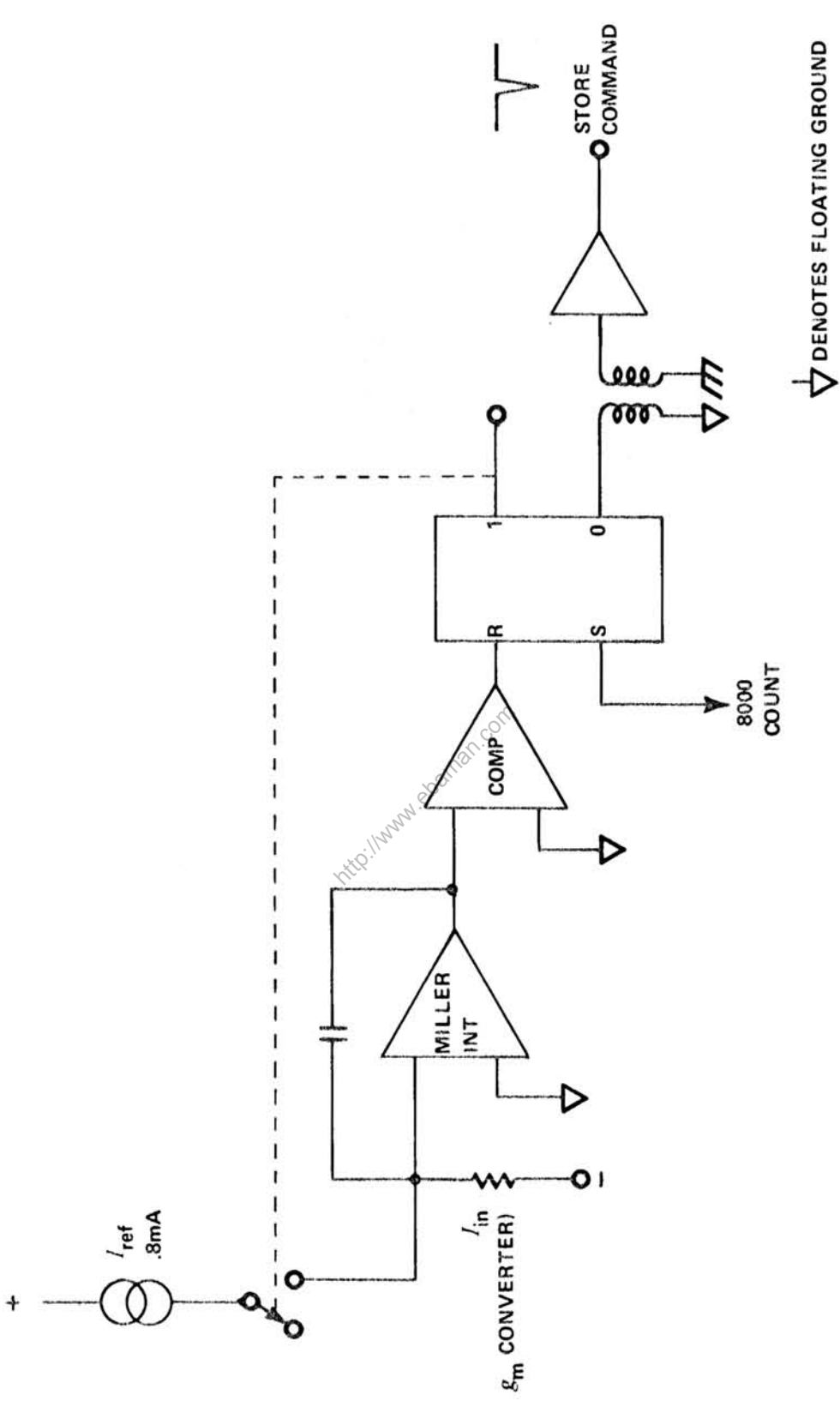
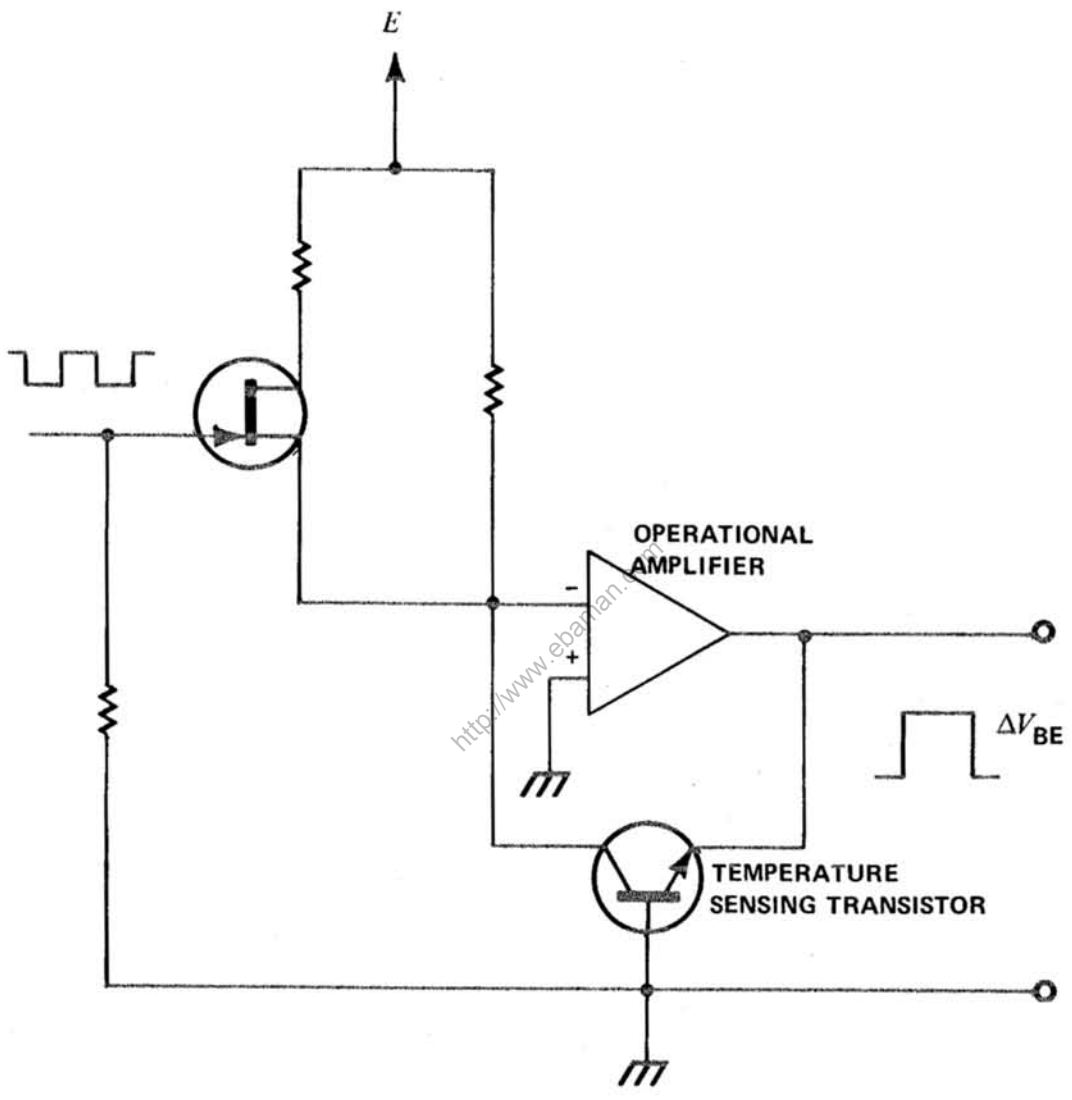

FIGURE 6 - 7D13 FUNCTIONAL BLOCK SN-74153



7013 SIMPLIFIED INTEGRATOR AND COMPARATOR



7D13 V_{BE} AS TEMP INDICATOR CIRCUIT

B-7D13-0010

