

**CS10V SINGLE TRACE  
10MHZ OSCILLOSCOPE**

**USER'S MANUAL**



---

# CONTENTS

---

## **1. SAFETY PRECAUTION**

## **2. SPECIFICATIONS**

2.1 VERTICAL SYSTEM

2.2 TRIGGER SYSTEM

2.3 HORIZONTAL SYSTEM

2.4 X-Y MODE

2.5 CALIBRATION

2.6 CRT

2.7 POWER SOURCE

2.8 PHYSICAL FEATURES

2.9 WORKING ENVIRONMENT

2.10 PRESSURE-PROOF TEST

## **3. CONTROL AND INDICATORS**

3.1 CONTROL PANEL POSITION

3.2 FUNCTIONS OF CONTROL SWITCHES

3.3 OPERATING INSTRUCTION

## **4. MEASUREMENT**

4.1 EXAMINATION AND ADJUSTMENT BEFORE TAKING MEASUREMENT

4.2 MEASUREMENT OF VOLTAGE

4.3 TIME MEASUREMENTS

4.4 PHASE DIFFERENCE MEASUREMENTS

4.5 X - Y MODE APPLICATIONS

## **5. ACCESSORIES**

## 1. SAFETY PRECAUTION

CS10V is a portable Oscilloscope with frequency bandwidth of 0~10 MHz and sensitivity of 5mV/DIV~5V/DIV. Equipped with 10:1 probe which makes the sensitivity up to 50V/div. Sweep rate at 0.1S/DIV ~ 0.1 $\mu$ S/DIV on horizontal system. The oscilloscope is easy to operate, and highly reliable. It is an ideal instrument for research, production, education, and development in electronic device or circuitry.

The instrument is designed and tested in accordance with EN publication 61010, CAT II, Pollution degree II and Overvoltage 600V. The instrument has been tested in accordance to the following EC Directives (EMC) :

- a. EN50082
- b. EN55011
- c. EN610000-3-2
- d. EN61000-3-3

The instrument complies with the requirements of the European Council Directive 89/336/EEC (EMC Directive) and 73/23/EEC (Low Voltage Directive). To ensure that the instrument is used safely, follow all safety and operating instructions in this manual. If the instrument is not used as described in this manual, the safety features might be impaired.

### WARNING



Non compliance with the warnings and/or the instructions for use may damage the instrument and/or its components or injure the operator.

Take extreme care for the following conditions when using the instrument :

- For your own safety and that of the instrument, you must follow the procedures described in this instruction manual and especially read all the notes preceded by the symbol  carefully.
- Do not use this instrument in a location where there is explosive gas in the vicinity. The use of this instrument in a location where there is explosive gas could result in explosion.
- If there is any smoke, abnormal odor, or abnormal sound coming display type this instrument, immediately switch off the power and disconnect the power cord. Continuous using of this instrument under these conditions could result in electrical shock or fire. After disconnecting the power cord, contact the service offices for repair. Repair by the user is dangerous and should be strictly avoided.

- Take care not to allow water to get into this instrument or the wetting of the instrument. The use of this instrument in a wet state could result in electrical shock or fire. If water or other foreign matter has gotten into this instrument, first switch the power off, remove the power cord and call for repair.
- Do not place this instrument on an unstable place such as on a shaky stand or on a slant. The dropping or turning over of this instrument could result in electrical shock, injury or fire. If this instrument has dropped or its cover has been damaged, switch the power off, remove the power cord and call for repair.
- Do not allow any foreign matter such as metal or inflammable substance to get in from the air hole. The entrance of any foreign matter from the ventilation port, etc., could result in fire, electrical shock, or power failure.
- Use this instrument with the rated AC power supply. Use of this instrument with a voltage other than specified could result in electrical shock, fire or power failure. The usable power voltage range is marked on the rear panel.
- Do not remove either the cover or panel.
- Take sufficient care when measuring high voltages.
- Do not modify this instrument.
- Avoid use of any damaged cable or adapter.

## 2. SPECIFICATIONS

### 2.1 VERTICAL SYSTEM

Sensitivity	5mV/DIV. ~5V/DIV $\pm 3\%$
Trimming Ratio	$\geq 2.5:1$
Rise Time	$\leq 35\text{ns}$
Bandwidth(-3dB)	DC:0~10MHz AC:10Hz~10MHz
Input Impedance	1M $\Omega$ $\pm 3\%$ , 30 pF $\pm 5\text{pF}$
Max. Input Voltage	400V pk

### 2.2 TRIGGER SYSTEM

Trigger Sensitivity	Int 1 div., Ext 0.3V
Ext. Trigger Input Impedance	1M $\Omega$ 30pF
Ext. Trigger Max. Input Voltage	400Vpk
Trigger Sources	Int, Line, Ext
Trigger Mode	Norm, AUTO, TV

### 2.3 HORIZONTAL SYSTEM

Sweep Time	0.1S / DIV ~0.1 $\mu\text{S}$ / DIV $\pm 3\%$
Trimming Ratio	$\geq 2.5:1$

**2.4 X-Y MODE**

Sensitivity	0.2V/DIV~0.5V/DIV
Bandwidth(-3dB)	DC: 0~1MHz AC: 10Hz~1MHz

**2.5 CALIBRATION SIGNAL**

Waveform	Symmetric Square Wave
Range	05.V $\pm$ 2%
Frequency	1kHz $\pm$ 2%

**2.6 CRT**

Display Area	8 $\times$ 10DIV 1DIV=6mm
Accelerating Voltage	1200V
Display Color	Green

**2.7 POWER SOURCE**

Voltage Range	220V $\pm$ 10%
Frequency	50Hz $\pm$ 2Hz
Power Consumption	25W

**2.8 PHYSICAL FEATURES**

Weight	3kg
Dimensions (H x W x D)	190 $\times$ 130 $\times$ 270mm

**2.9 WORKING ENVIRONMENT**

Working temperature	5°C ~ 40°C
Storage Environment	-30°C ~60°C, 10~80%RH
Working Altitude	$\leq$ 2000m

**2.10 PRESSURE-PROOF TEST**

Pressure-proof test	1500V 1min
---------------------	------------

### 3. CONTROL AND INDICATORS

#### 3.1 Control Panel Position

##### 3.1.1 Front Panel **Fig 3-1**

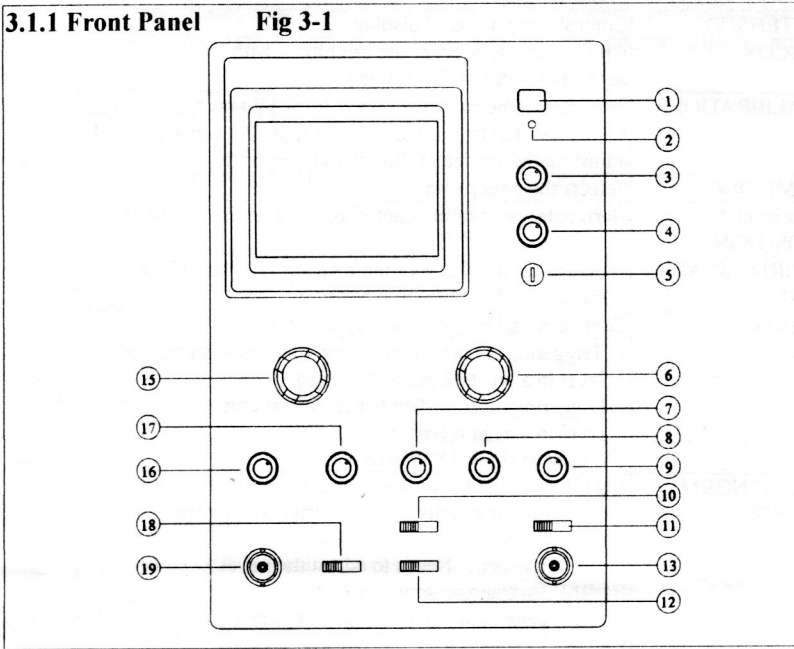

##### 3.1.2 Rear Panel **Fig 3-2**

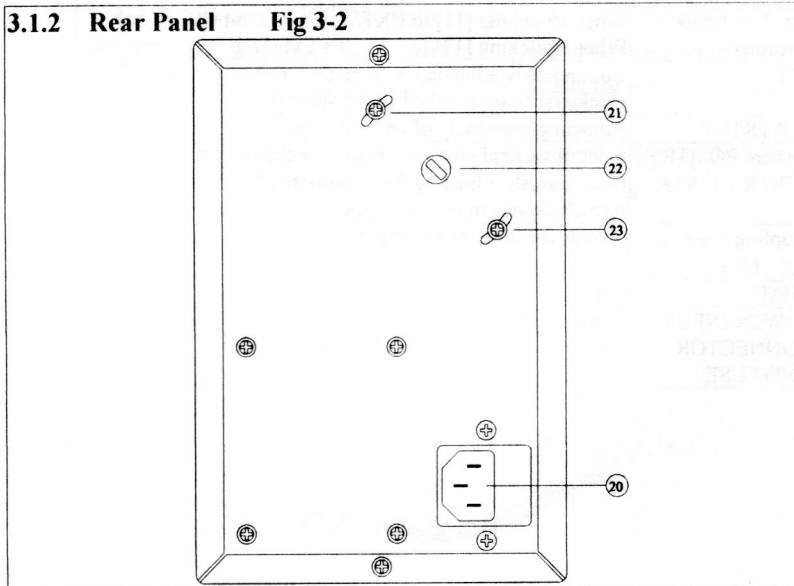

### 3.2 FUNCTIONS OF CONTROL SWITCHES

NO.	SWITCHES	FUNCTIONS
1	POWER SWITCH	Power on/off
2	POWER LIGHT	Lights when power on
3	INTENSITY	Controls brightness of display
4	FOCUS	After obtaining appropriate brightness with INTENSITY, adjust FOCUS for clearest line
5	CALIBRATION	Provide symmetric square wave for 0.5V range, frequency=1KHz. Used for adjusting 10:1 Capacitor and adjusting the vertical & horizontal sensitivity.
6	TIME/DIV	Selects the sweep rate
7	Horizontal POSITION	Horizontal positioning control of trace on the screen
8	HORIZONTAL VAR	Provides continuously variable sweep rate, turn clock wise to the end is the calibrating position
9	LEVEL	Control signal trigger to sweep at certain level
10	+/- TV	+: Triggering occurs when trigger signal crosses trigger level in a positive-going direction. -: Triggering occurs when trigger signal crosses trigger level in a negative-going direction TV: used to show TV signals
11	AUTO/NORM EXT/X	AUTO : a single trace shown on screen even no signal. Automatically reverts to triggered sweep operation when adequate triggered signal is present. Needs to adjust the Level. NORM: No trace on screen if no signal. Trace is only generated when adequate trigger signal is present EXT/X: X-Y switch
12	INT/EXT/LINE	Switch to select the Trigger Source INT/EXT/LINE
13	Ext. Trig Input Terminal	When switching [11] to EXT/X, it's X-Y input terminal; When switching [12] to EXT, it's Ext. Trig. Input terminal.
14	ATT	Continuously adjusting X-Y mode sensitivity, turn clockwise to obtain the highest sensitivity
15	VOLTS/DIV	Adjusting sensitivity of vertical system
16	Vertical POSITION	Control vertical position of trace on the screen
17	VERTICAL VAR	Continuously adjusting the sensitivity of vertical system, turn clockwise to the end is the calibration position
18	coupling options (AC⊥DC)	Selects input coupling options
19	INPUT	Vertical input terminal
20	POWER INPUT CONNECTOR AND FUSE	power input connector (refer to the rear panel for voltage) 220 V ±10%; fuse 2 x 0.5A (on rear panel)

### 3.3 OPERATING INSTRUCTION

#### 3.3.1 VOLTAGE CHECKING

CS10V oscilloscope use 220V  $\pm 10\%$  voltage. Before using, make sure that the correct voltage is being used. Otherwise, it would cause accident and damage to the instrument.

#### 3.3.2 BASIC OPERATION

##### (1) POSITION FOR CONTROL SWITCHES

CONTROL SWITCHES	POSITION
INTENSITY [3]	Center
FOCUS [4]	Center
POSITION [7] [16]	Center
VOLTS/DIV [15]	0.1V
VAR [8] [17]	Calibration position
AUTO/NORM [11]	Auto
TIME/DIV [6]	0.5mS
SLOPE +/- [10]	+
INT/EXT/LINE [12]	Int
AC⊥DC [18]	DC

##### (2) OPERATION

- a. Power on [1],
- b. Power lights at [2],
- c. Allow for warm-up of about 5 minutes, then adjust the intensity[3],
- d. Adjust focus [4] for clearest line. If unstable, adjust level [9] .

##### (3) Horizontal Level Adjustment :

- a. Slightly turn [21], [23] counter clockwise, but not to unscrew;
- b. Insert a straight end screw driver to [22], and observe the wave, move screw driver in order to let the waveform parallel with the horizontal line ;
- c. Screw the [21] , [23].

(4) Connects the calibration signal [5] to Y input terminal[19] with 1:1 probe

(5) Adjust positions [7] , [16] to obtain waveform like Fig 3-3.

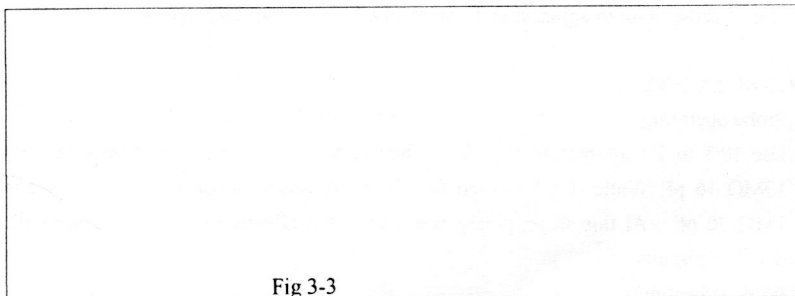

Fig 3-3

### 3.3.3 VERTICAL SYSTEM OPERATION

- (1) VOLTS/DIV switch should turn to correct position following the input signal range. Adjust position [16] to show the whole waveform within available area. Adjust with VAR [17] if necessarily, trimming ratio is  $\geq 2.5:1$ .
- (2) Input coupling options: "DC" is used for observing object with direct current signal such as logical and static signals, "DC" must be used with low frequency. "AC" is used for observing the AC component of signals. "┴" is used to establish a trace at the zero volt reference.
- (3) X-Y OPERATION: When [11] set at EXT/X, The oscilloscope is used for X-Y operation, at this moment Input [19] is Y-axis with the same sensitivity, Input [13] as X-axis, [14] can be adjusted continuously within  $0.2V/DIV \sim 0.5V/DIV$ .

### 3.3.4 TRIGGER SOURCE

In Fig 3-1, [12] provides 3 sources for selection, INT trigger, EXT trigger input from [13], LINE input from power source.

### 3.3.5 HORIZONTAL SYSTEM OPERATION

- (1) Sweep setup : turn the sweep switch to correct position according to signal frequency, adjust POSITION [7] to show the whole waveform within available area. Adjust with VAR [8] if necessarily, trimming ratio is  $\geq 2.5:1$ .
- (2) There are 3 kinds of Trigger sources: [11] "AUTO" auto sweep, when triggering signal is applied, Level [9] will adjust to proper position. The screen showing steady free run wave required frequency higher than 20Hz; [11] "NORM" while waiting for sweep, no trace; when receiving input signal, the circuits was triggered to sweep and show waveform. [10] "TV" used to determine TV signal. The signal is negative.
- (3) SLOPE selection: Used to select whether the trigger signal crosses trigger level in a positive-going or a negative-going direction.
- (4) Level setup : Use to adjust signal sweep on a level as starting reference.

### 3.3.6 SIGNAL CONNECT

- (1) Probe operating :

Use 10:1 to 1:1 alternating probes. When using 10:1 probe, input impedance is  $10M\Omega$  16 pF. While if 1:1 is used for observing lower signal, input impedance is  $1M\Omega$  30 pF. At this stage, please consider of the affection of the probe upon the detected circuits.

- (2) Probe Adjustment

Before using , 10:1 probe must be adjusted correctly, see Point 4.1.2

## 4 Measurement

### 4.1 EXAMINATION AND ADJUSTMENT BEFORE MEASUREMENT

In order to be more accurate and prevent errors, the following observations should be done before taking measurement.

#### 4.1.1 TRACE ROTATION

Generally, horizontal trace on the screen should parallel with the horizontal line. Due to the earth's magnetic field and other factors which might cause horizontal trace leaning and making errors, you must examine the followings before taking measurement:

- (1) Adjust the switches on the front panel, get a horizontal trace on the screen .
- (2) Adjust vertical position and make sweep baseline lied in horizontal line of vertical central
- (3) Examine whether sweep baseline is parallel with horizontal line, if not , follow point 3.3.2(3) to make adjustment .

#### 4.1.2 PROBE COMPENSATION

Adjustment of probe is useful to compensate mistakes cause by difference of the scope's input characteristics:

- (1) Follow step 3.3.2, setup front panel components, and get a sweep baseline.
- (2) Set VOLTS/DIV to 10mV/DIV.
- (3) Connect CH1 10:1 probe to input terminal, and connect with "CAL".
- (4) Follow Chapter 3 to operate relative components, obtain waveform on the screen as figure 4.1
- (5) Observe whether the waveform compensation is good, if not , you can adjust the LF compensation components as shown in figure 4.2

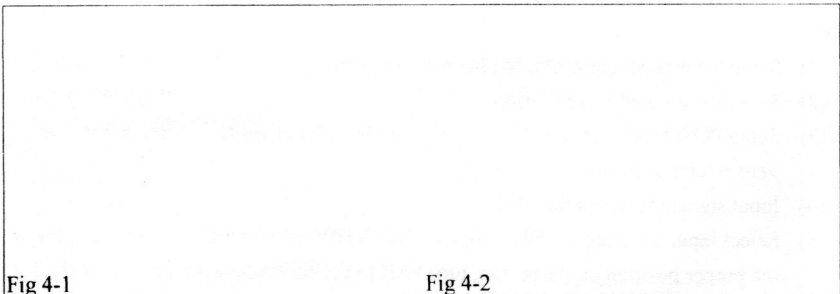

Fig 4-1

Fig 4-2

## 4.2 MEASUREMENT

### 4.2.1P-P Voltage Measurements

Step :

- (1) Input signal to INPUT [19] terminal.
- (2) Setup VOLTS/DIV and observe waveform, let waveform display on the screen within 5 divisions, and turn VAR clockwise to the calibration position.
- (3) Adjust level to make waveform steady.
- (4) Adjust sweep controls to obtain at least one cycle waveform on the screen.
- (5) Adjust vertical position to make the bottom of waveform show on a horizontal axis on the screen. Fig 4-3A.
- (6) Adjust horizontal position to make the top of waveform lied at the center of vertical axis like Fig 4-3B.
- (7) Read the divisions between A-B on vertical direction.
- (8) Calculate the signal  $V_{p-p}$  using the formula below :

$$V_{p-p} = \text{DIV of vertical direction} \times \text{Sensitivity}$$

For example, In Fig 4-3, vertical divisions of A-B is 4.1 DIV, sensitivity of the 10:1 probe is 2V/DIV, then  $V_{p-p} = 2 \times 4.1 = 8.2(V)$

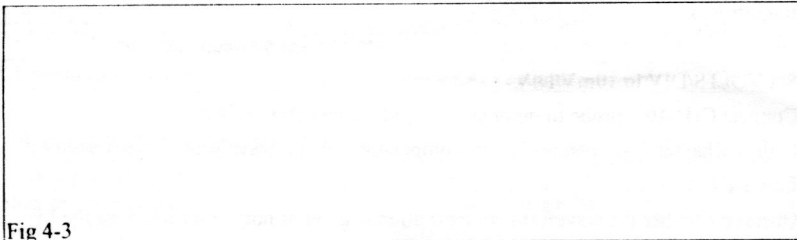

Fig 4-3

### 4.2.2 DC VOLTAGE MEASUREMENT

STEP:

- (1) Setup front panel connector to obtain a sweep baseline on the screen.
- (2) Setup input coupling options as "1".
- (3) Setup POSITION, let sweep baseline coincide with horizontal center, define it as zero reference level.
- (4) Input signal into terminal.
- (5) Select input coupling to "DC", adjust VOLTS/DIV, to have the waveform display at the proper position on the screen, turn VAR to the calibration position.
- (6) Read the divisions between the zero reference level to the waveform formed by the tested object.

(7) Calculate the DC voltage:

$$V = \text{divisions on vertical axis} \times \text{sensitivity} \times \text{direction}(+/-)$$

Shown in Figure 4-4, zero reference level at the center, use 10:1 probe, sensitivity is 2V/Div, 2 points as A & B, A is 1.5 Div. over the zero reference level, B is 3Div. below the zero reference level. DC voltage level of the 2 points are :

$$V_A = 1.5 \times 2 \times (+) = 3 \text{ V} \quad V_B = 3 \times 2 \times (-) = -6 \text{ V}$$

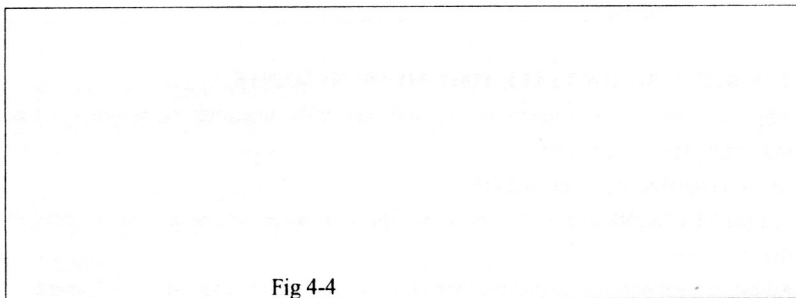

Fig 4-4

## 4.3 TIME MEASUREMENTS

### 4.3.1 TIME SPACE MEASUREMENTS

This is a procedure for taking time (period) measurements between two points on a waveform:

- (1) Connect the signal to be measured to the input terminal [19].
- (2) Adjust level to obtain steady waveform.
- (3) Turn VAR clockwise to the calibration position, and set sweep controls to obtain a normal display of 1-2 signal cycles.
- (4) Using the vertical and horizontal positions, set two points to be measured in the waveform on the same horizontal level.
- (5) Measure the distance between the two points, the measurement is calculated by the following equation:

$$\text{TIME (S)} = \frac{\text{Distance between 2 points (DIV)} \times \text{rate of sweep (t/Div)}}{\text{Horizontal factor}}$$

Shown in figure 4-6, distance between A & B is 8 Div. sensitivity is 2  $\mu$ S/Div, Horizontal factor x 1, then Time measurement is 16 $\mu$ S

Fig 4-6

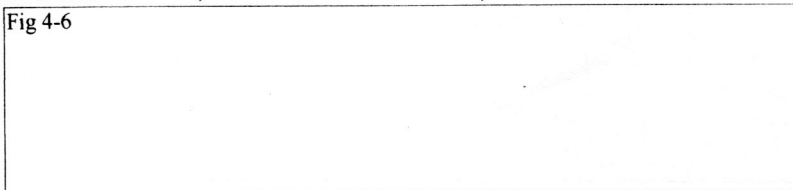

**4.3.2 CYCLE & FREQUENCY MEASUREMENTS**

Shown in Fig 4-6, frequency measurements are made by measuring the time period of one cycle of waveform (T), and calculating the frequency which equals to the reciprocal of the time period. For example, T=16μS, then frequency is:

$$F = 1/T = \frac{1}{16 \times 10^{-6}} = 62.5 \text{ KHz}$$

**4.3.3 PULSE RISE TIME AND FALL TIME MEASUREMENTS**

For rise time and fall time measurements, the 10% and 90% amplitude points are used as starting and ending reference points.

- (1) Apply a signal to the input jack [19].
- (2) Use the VOLTS/DIV and VAR controls to adjust the waveform peak to peak height to five divisions.
- (3) Adjust vertical position so that the tops of the waveform coincide with 100% point, while the bottoms of the waveform coincide with 0% point.
- (4) Adjust Sweep switch to obtain the positive-going direction or negative-going direction of the waveform on the screen.
- (5) Use the horizontal POSITION control to adjust the 10% points to coincide with a vertical graduation line.
- (6) Measure the horizontal distance in divisions between the 10% and 90% points on the waveform (divisions).
- (7) Pulse rise time and fall time measurement is calculated by the following equation:

$$\text{Rise Time} = \frac{\text{Horizontal distance (div)} \times \text{sensitivity (Time/div)}}{\text{Horizontal factor}}$$

For the example shown in Fig 4-7, the horizontal distance from 10% to 90% is 2.4 divisions, the sweep TIME/DIV setting is 1μS/DIV, factor x 1. The rise time is calculated as follows:

$$\text{Rise Time} = \frac{1\mu\text{S/DIV} \times 2.4\text{DIV}}{1} = 2.4\mu\text{S}$$

Fig. 4-7

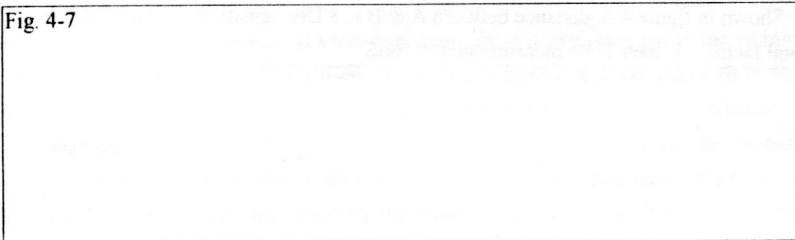

#### 4.4 TV Signals measurement

Steps :

- (1) Connect TV signals to INPUT jack [19]
- (2) Set Trigger method to "TV" [10], Sweep switch turn to 2mS/Div.
- (3) Observe the screen, it should be negative synchronize pulse wave.
- (4) Adjust VOLTS/DIV and VAR to obtain proper range.

#### 4.5 X- Y mode applications

There are some cases which X axis requires control from external signals, e.g. external connection of sweep signals, signals of Lissajous pattern or other equipment's display setup. X-Y mode operation is turn [11] to EXT/X, input signals through [13], sensitivity to be adjusted directly with [14], then input Y signal through [19].

### 5. ACCESSORIES

- 1 Probe 1 pc.
- 2 Cord 1 pc.
- 3 User's manual



**WARNING**

**DO NOT OPEN THE CASE, HIGH VOLTAGE EXISTED.**

# CS10V\_Component layer

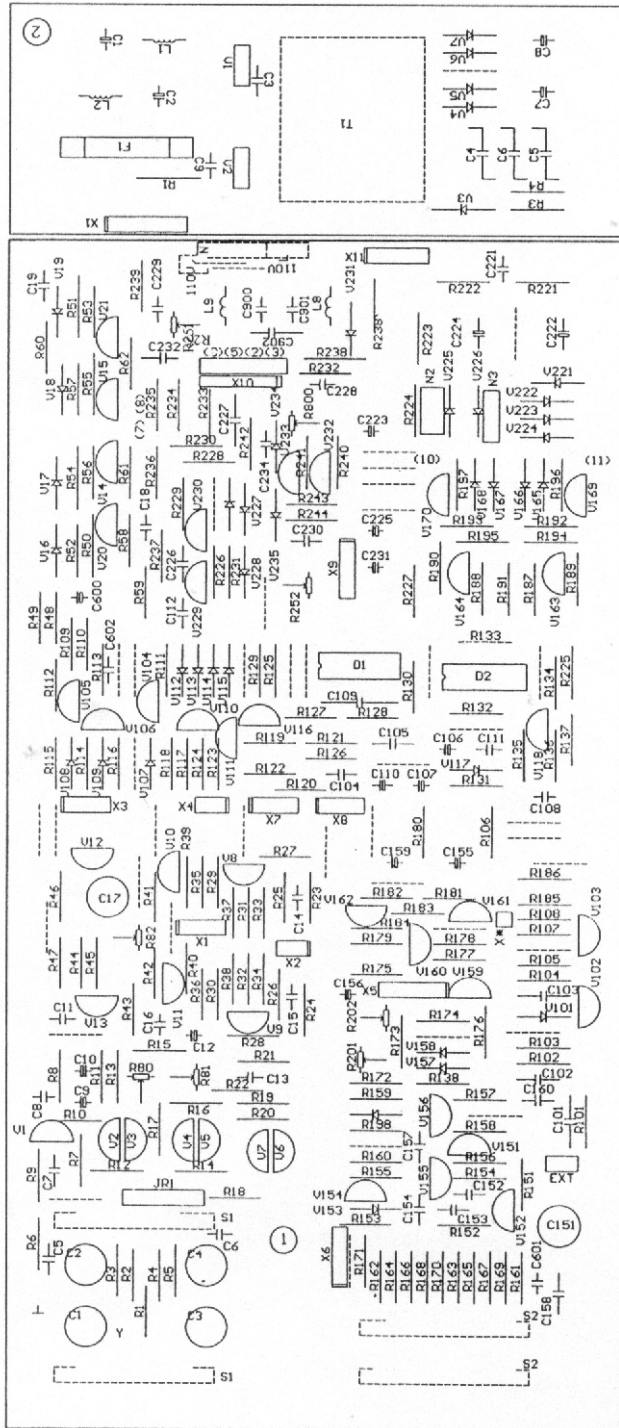



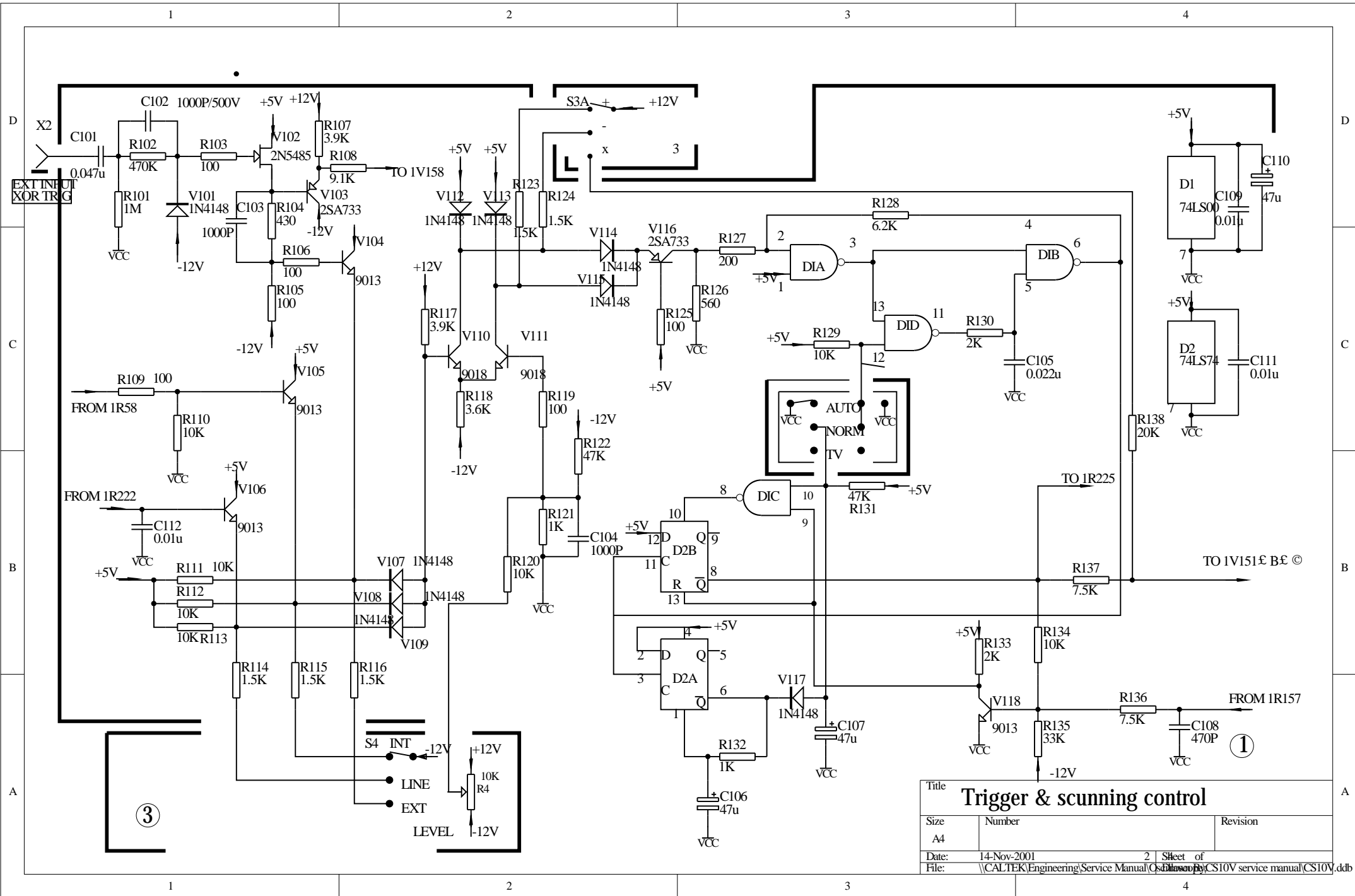

Title		
<b>Trigger &amp; scanning control</b>		
Size	Number	Revision
A4		
Date:	14-Nov-2001	2 Sheet of
File:	\\CALTEK\Engineering\Service Manual\Osaka\B&E\CS10V service manual\CS10V.ddb	

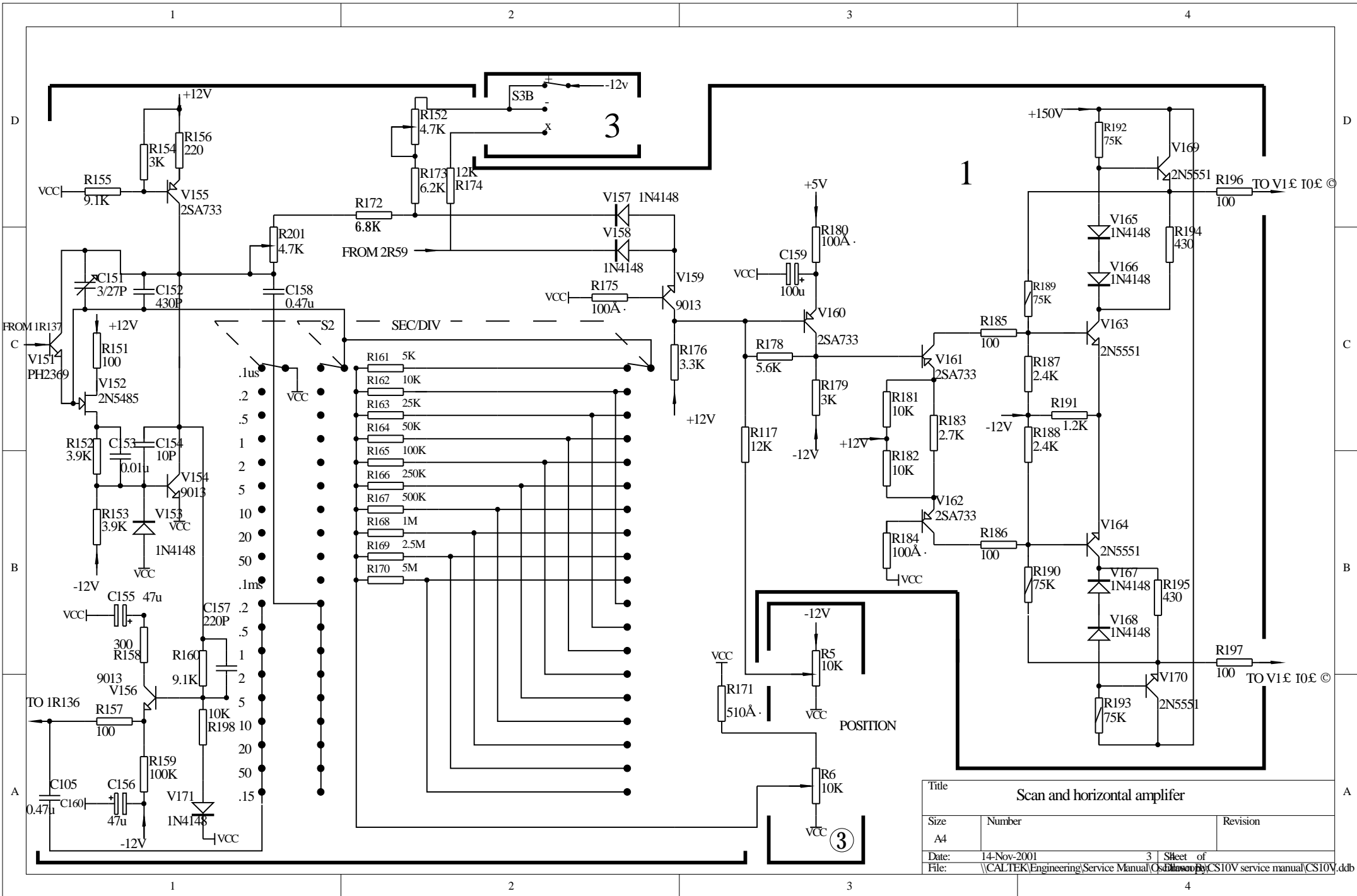

Title		
Scan and horizontal amplifier		
Size	Number	Revision
A4		
Date:	14-Nov-2001	3 Sheet of
File:	\CALTEK\Engineering\Service Manual\CS10V\CS10V service manual\CS10V.ddb	

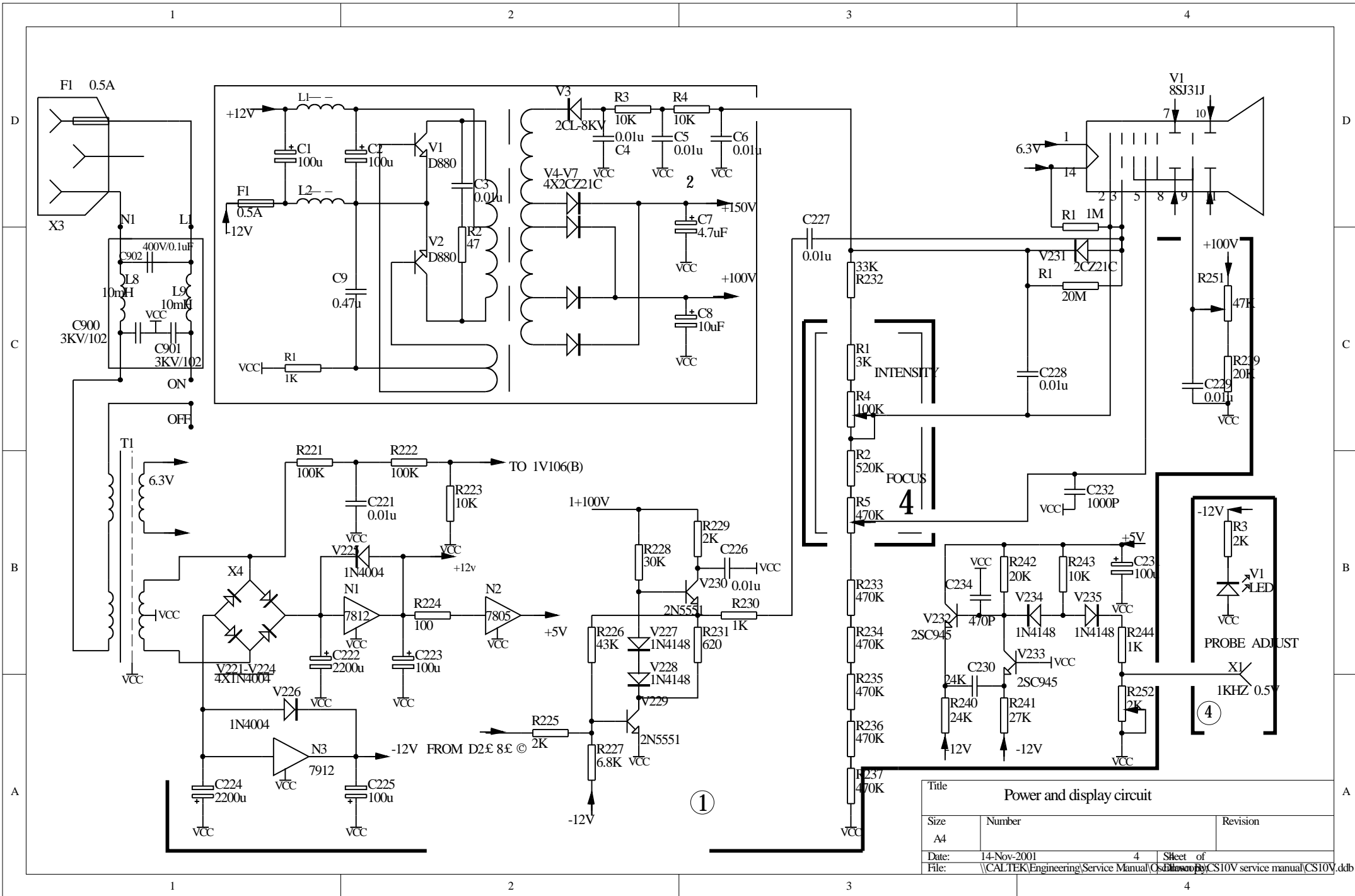

Title		
Size	Number	Revision
A4		
Date:	14-Nov-2001	4 Sheet of
File:	\\CALTEK\Engineering\Service Manual\CS10V\CS10V service manual\CS10V.ddb	