

an *ALLIED* publication



ALLIED

ELECTRONICS DATA

HANDBOOK



FORMULAS AND DATA

COMMONLY USED

IN ELECTRONICS

TABLE OF CONTENTS

Fundamental Mathematical Data	4-5
Mathematical Constants	4
Mathematical Symbols	4
Decimal Parts of an Inch	4
Fundamental Algebraic Formulas	5
Decibel Tables, Attenuators and Matching Pads	5-10
Decibels, Fundamental Formulas	5
DB Expressed in Watts and Volts	5
Decibel-Voltage, Current and Power Ratio Table	6
Table of Values for Attenuator Network Formulas	7
Attenuator Network Formulas	8-9
Minimum Loss Pads	10
Most Used Radio and Electronic Formulas	11-29
70-Volt Loud-Speaker Matching Formulas	11
Resistance	12
Capacitance	12
Inductance	12-13
Reactance	13
Resonance	13
Frequency and Wavelength	13
"Q" Factor	14
Impedance	14-16
Conductance	17
Susceptance	17
Admittance	17
Transient I and E in LCR Circuits	18-19
Steady State Current Flow	19
Transmission Line Formulas	20
Capacity of a Vertical Antenna	20
Trigonometric Relationships	21
Vacuum Tube Formulas and Symbols	22
R.M.S., Peak and Average Volts and Current	22
Transistors—Basic Formulas, Symbols and Circuits	23-25
D-C Meter Formulas	26-27
Ohm's Law for A-C and D-C Circuits	28-29
Engineering and Servicing Data	30-69
R-F Coil Winding Formulas	30
Wire Table	31
R-F Coil Winding Data Chart	32-33
Inductance, Capacitance, Reactance Charts	33-36
Metric Relationships	37
How to Use Logarithms	38-40
Directly Interchangeable Tubes	41-51
Directly Interchangeable TV Picture Tubes	52-55
Abbreviations and Letter Symbols	55, 67
Pilot Lamp Data	56-57
Interchangeable Batteries	58-59
EIA and Military Color Codes for Resistors and Capacitors	60-63
EIA Color Codes for Chassis Wiring	64-66
Schematic Symbols Used in Radio Diagrams	68-69
Log and Trig Tables	70-77
Four-Place Common Log Tables	70-71
Table of Natural Sines, Cosines and Tangents	72-77
Allied Publications	78-79
Index	80

INDEX

Abbreviations	23, 67	Ohm's Law	28-29
Admittance	17	Open-Air Transmission Lines	20
Algebraic Formulas	5	Peak Current	22
Algebraic Symbols	4	Peak Volts	22
Attenuator Networks	7-9	Phase Angle	28
Average Current	22	Pilot Lamp Data	56-57
Average Volts	22	Power Factor	28
Capacitance	12, 20, 33-36, 60-63	"Q" Factor	14
Capacitors	12, 60-63	Quadratic Equations	5
Coefficient of Coupling	13	R-F Coils	30, 32-33
Coils	30, 32-33	R.M.S. Current	22
Concentric Transmission Lines	20	R.M.S. Volts	22
Conductance	17	Radicals and Exponents	5
Constants	4, 12, 22	Radio Color Codes	60-66
Conversion Chart	37	Reactance	13, 33-36
Coulombs	12	Resistance	12, 26, 28-29
Coupled Inductance	12	Resistor-Capacitor Color Codes	60-63
Coupling Coefficient	13	Resistors	60
Decay of E & I in LCR Circuits	18-19	Resonance	13, 33-36
Decibels	5-6	Schematic Symbols	68-69
Diagram Symbols	68-69	Self-Inductance	12
Dielectric Constants	12	Shunts	26-27
Exponents and Radicals	5	Solution of a Quadratic	5
Fractional Inches	4	Speaker Matching—70 Volt System	11
Frequency	13, 20, 33-36	Steady State I and E	19
Growth of E & I in LCR Circuits	18-19	Susceptance	17
Impedance	14-16, 20	Symbols	23, 67-69
Inches to Millimeters	4	Transient I and E	18-19
Inductance	12, 13, 30, 32-36	Transistor Circuits	24-25
Interchangeable Batteries	58-59	Transistor Formulas	23
Interchangeable Tubes	41-55	Transistor Symbols	23
Log Tables	70-71	Transmission Lines	20
Logarithms—How to Use	38-40	Trigonometric Formulas	21
Mathematical Constants	4	Trigonometric Functions	21
Mathematical Symbols	4	Trigonometric Tables	72-77
Meter Formulas	26-27	Vacuum Tube Constants	22
Metric Relationships	37	Vacuum Tube Formulas	22
Millimeters to Inches	4	Vacuum Tube Symbols	22
Mixers	9	Vertical Antenna, Capacitance	20
Multipliers	26-27	Wavelength	13, 20
Minimum Loss Pads	10	Wire Tables	30-31
Mutual Inductance	13		

Mathematical Symbols

- × or · Multiplied by
- + or : Divided by
- + Positive. Plus. Add
- Negative. Minus. Subtract
- ± Positive or negative. Plus or minus
- + Negative or positive. Minus or plus
- = or :: Equals
- ≡ Identity
- ≈ Is approximately equal to
- ≠ Does not equal
- > Is greater than
- ≫ Is much greater than
- < Is less than
- ≪ Is much less than
- ≥ Greater than or equal to
- ≤ Less than or equal to
- ∴ Therefore
- ∠ Angle
- Δ Increment or Decrement
- ⊥ Perpendicular to
- ∥ Parallel to
- |n| Absolute value of n

Mathematical Constants

- $\pi = 3.14$
- $2\pi = 6.28$
- $(2\pi)^2 = 39.5$
- $4\pi = 12.6$
- $\pi^2 = 9.87$
- $\frac{\pi}{2} = 1.57$
- $\frac{1}{\pi} = 0.318$
- $\frac{1}{2\pi} = 0.159$
- $\frac{1}{\pi^2} = 0.101$
- $\frac{1}{\sqrt{\pi}} = 0.564$
- $\sqrt{\pi} = 1.77$
- $\sqrt{\frac{\pi}{2}} = 1.25$
- $\sqrt{2} = 1.41$
- $\sqrt{3} = 1.73$
- $\frac{1}{\sqrt{2}} = 0.707$
- $\frac{1}{\sqrt{3}} = 0.577$
- $\log \pi = 0.497$
- $\log \frac{\pi}{2} = 0.196$
- $\log \pi^2 = 0.994$
- $\log \sqrt{\pi} = 0.248$

Decimal Inches

- Inches × 2.540 = Centimeters
- Inches × 1.578 × 10⁻⁵ = Miles
- Inches × 10³ = Mills

Inches		Decimal Equivalent	Millimeter Equivalent
1/64	1/32	.0156 .0313	0.397 0.794
3/64		.0469 .0625	1.191 1.588
5/64	3/32	.0781 .0938	1.985 2.381
7/64		.1094 .1250	2.778 3.175
9/64	5/32	.1406 .1563	3.572 3.969
11/64		.1719 .1875	4.366 4.762
13/64	7/32	.2031 .2188	5.159 5.556
15/64		.2344 .2500	5.953 6.350
17/64	9/32	.2656 .2813	6.747 7.144
19/64		.2969 .3125	7.541 7.937
21/64	11/32	.3281 .3438	8.334 8.731
23/64		.3594 .3750	9.128 9.525
25/64	13/32	.3906 .4063	9.922 10.319
27/64		.4219 .4375	10.716 11.112
29/64	15/32	.4531 .4688	11.509 11.906
31/64		.4844 .5000	12.303 12.700
33/64	17/32	.5156 .5313	13.097 13.494
35/64		.5469 .5625	13.891 14.287
37/64	19/32	.5781 .5938	14.684 15.081
39/64		.6094 .6250	15.478 15.875
41/64	21/32	.6406 .6563	16.272 16.669
43/64		.6719 .6875	17.067 17.463
45/64	23/32	.7031 .7188	17.860 18.258
47/64		.7344 .7500	18.655 19.049
49/64	25/32	.7656 .7813	19.446 19.842
51/64		.7969 .8125	20.239 20.636
53/64	27/32	.8281 .8438	21.033 21.430
55/64		.8594 .8750	21.827 22.224
57/64	29/32	.8906 .9063	22.621 23.018
59/64		.9219 .9375	23.415 23.812
61/64	31/32	.9531 .9688	24.209 24.606
63/64		.9844 1.0000	25.004 25.400

Algebra

Exponents and Radicals

$$a^x \times a^y = a^{(x+y)}, \quad \frac{a^x}{a^y} = a^{(x-y)}$$

$$(ab)^x = a^x b^x, \quad \left(\frac{a}{b}\right)^x = \frac{a^x}{b^x}$$

$$\sqrt[x]{\frac{a}{b}} = \frac{\sqrt[x]{a}}{\sqrt[x]{b}}, \quad a^{-x} = \frac{1}{a^x}$$

$$(a^x)^y = a^{xy}, \quad \sqrt[x]{\sqrt[y]{a}} = \sqrt[xy]{a}$$

$$\sqrt[x]{ab} = \sqrt[x]{a} \sqrt[x]{b}, \quad a^{\frac{x}{y}} = \sqrt[y]{a^x}$$

$$a^{\frac{1}{x}} = \sqrt[x]{a}, \quad a^0 = 1$$

Solution of a Quadratic

Quadratic equations in the form

$$ax^2 + bx + c = 0$$

may be solved by the following:

$$x = \frac{-b \pm \sqrt{b^2 - 4ac}}{2a}$$

Transposition of Terms

If $A = \frac{B}{C}$, then $B = AC$, $C = \frac{B}{A}$.

If $\frac{A}{B} = \frac{C}{D}$, then $A = \frac{BC}{D}$,

$$B = \frac{AD}{C}, \quad C = \frac{AD}{B}, \quad D = \frac{BC}{A}$$

If $A = \frac{1}{D\sqrt{BC}}$, then $A^2 = \frac{1}{D^2 BC}$,

$$B = \frac{1}{D^2 A^2 C}, \quad C = \frac{1}{D^2 A^2 B}, \quad D = \frac{1}{A\sqrt{BC}}$$

If $A = \sqrt{B^2 + C^2}$, then $A^2 = B^2 + C^2$,

$$B = \sqrt{A^2 - C^2}, \quad C = \sqrt{A^2 - B^2}$$

Decibels

The number of db by which two power outputs P_1 and P_2 (in watts) may differ, is expressed by

$$10 \log \frac{P_1}{P_2};$$

or in terms of volts,

$$20 \log \frac{E_1}{E_2};$$

or in current,

$$20 \log \frac{I_1}{I_2}$$

While power ratios are independent of source and load impedance values, voltage and current ratios in these formulas hold true only when the source and load impedances Z_1 and Z_2 are equal. In circuits where these impedances differ, voltage and current ratios are expressed by,

$$db = 20 \log \frac{E_1 \sqrt{Z_2}}{E_2 \sqrt{Z_1}} \quad \text{or,} \quad 20 \log \frac{I_1 \sqrt{Z_1}}{I_2 \sqrt{Z_2}}$$

DB Expressed in Watts & Volts

DB*	Above Zero Level		Below Zero Level	
	Watts	Volts	Watts	Volts
0	0.0010	0.775	1.00×10^{-3}	0.7746
1	0.0013	0.869	7.94×10^{-4}	0.6904
2	0.0016	0.975	6.31×10^{-4}	0.6153
3	0.0020	1.094	5.01×10^{-4}	0.5483
4	0.0025	1.227	3.98×10^{-4}	0.4888
5	0.0032	1.377	3.16×10^{-4}	0.4356
6	0.0040	1.545	2.51×10^{-4}	0.3883
7	0.0050	1.734	2.00×10^{-4}	0.3460
8	0.0063	1.946	1.59×10^{-4}	0.3084
9	0.0079	2.183	1.26×10^{-4}	0.2748
10	0.0100	2.449	1.00×10^{-4}	0.2449
11	0.0126	2.748	7.94×10^{-5}	0.2183
12	0.0159	3.084	6.31×10^{-5}	0.1946
13	0.0200	3.460	5.01×10^{-5}	0.1734
14	0.0251	3.882	3.98×10^{-5}	0.1545
15	0.0316	4.356	3.16×10^{-5}	0.1377
16	0.0398	4.888	2.51×10^{-5}	0.1228
17	0.0501	5.483	2.00×10^{-5}	0.1095
18	0.0631	6.153	1.59×10^{-5}	0.0975
19	0.0794	6.904	1.26×10^{-5}	0.0869
20	0.1	7.746	10^{-5}	7.75×10^{-3}
30	1.0	24.493	10^{-6}	2.45×10^{-3}
40	10.0	77.460	10^{-7}	7.75×10^{-4}
50	10^2	244.93	10^{-8}	2.45×10^{-4}
60	10^3	774.60	10^{-9}	7.75×10^{-5}
70	10^4	2,449.0	10^{-10}	2.45×10^{-5}
80	10^5	7,746.0	10^{-11}	7.75×10^{-6}
90	10^6	24,493.0	10^{-12}	2.45×10^{-6}
100	10^7	77,460.0	10^{-13}	7.75×10^{-7}

*Zero db = 1 milliwatt into a 600 ohm load. Power ratios hold for any impedance, but voltages must be referred to an impedance load of 600 ohms.

Decibel—Voltage, Current and Power Ratio Table

-		DB	+		-		DB	+	
Voltage or Current Ratio	Power Ratio		Voltage or Current Ratio	Power Ratio	Voltage or Current Ratio	Power Ratio		Voltage or Current Ratio	Power Ratio
1.0000	1.0000	0	1.000	1.000	.4898	.2399	6.2	2.042	4.169
.9886	.9772	.1	1.012	1.023	.4842	.2344	6.3	2.065	4.266
.9772	.9550	.2	1.023	1.047	.4786	.2291	6.4	2.089	4.365
.9661	.9333	.3	1.035	1.072	.4732	.2239	6.5	2.113	4.467
.9550	.9120	.4	1.047	1.096	.4677	.2188	6.6	2.138	4.571
.9441	.8913	.5	1.059	1.122	.4624	.2138	6.7	2.163	4.677
.9333	.8710	.6	1.072	1.148	.4571	.2089	6.8	2.188	4.786
.9226	.8511	.7	1.084	1.175	.4519	.2042	6.9	2.213	4.898
.9120	.8318	.8	1.096	1.202	.4467	.1995	7.0	2.239	5.012
.9016	.8128	.9	1.109	1.230	.4416	.1950	7.1	2.265	5.129
.8913	.7943	1.0	1.122	1.259	.4365	.1905	7.2	2.291	5.248
.8810	.7762	1.1	1.135	1.288	.4315	.1862	7.3	2.317	5.370
.8710	.7586	1.2	1.148	1.318	.4266	.1820	7.4	2.344	5.495
.8610	.7413	1.3	1.161	1.349	.4217	.1778	7.5	2.371	5.623
.8511	.7244	1.4	1.175	1.380	.4169	.1738	7.6	2.399	5.754
.8414	.7079	1.5	1.189	1.413	.4121	.1698	7.7	2.427	5.888
.8318	.6918	1.6	1.202	1.445	.4074	.1660	7.8	2.455	6.026
.8222	.6761	1.7	1.216	1.479	.4027	.1622	7.9	2.483	6.166
.8128	.6607	1.8	1.230	1.514	.3981	.1585	8.0	2.512	6.310
.8035	.6457	1.9	1.245	1.549	.3936	.1549	8.1	2.541	6.457
.7943	.6310	2.0	1.259	1.585	.3890	.1514	8.2	2.570	6.607
.7852	.6166	2.1	1.274	1.622	.3846	.1479	8.3	2.600	6.761
.7762	.6026	2.2	1.288	1.660	.3802	.1445	8.4	2.630	6.918
.7674	.5888	2.3	1.303	1.698	.3758	.1413	8.5	2.661	7.079
.7586	.5754	2.4	1.318	1.738	.3715	.1380	8.6	2.692	7.244
.7499	.5623	2.5	1.334	1.778	.3673	.1349	8.7	2.723	7.413
.7413	.5495	2.6	1.349	1.820	.3631	.1318	8.8	2.754	7.586
.7328	.5370	2.7	1.365	1.862	.3589	.1288	8.9	2.786	7.762
.7244	.5248	2.8	1.380	1.905	.3548	.1259	9.0	2.818	7.943
.7161	.5129	2.9	1.396	1.950	.3508	.1230	9.1	2.851	8.128
.7079	.5012	3.0	1.413	1.995	.3467	.1202	9.2	2.884	8.318
.6998	.4898	3.1	1.429	2.042	.3428	.1175	9.3	2.917	8.511
.6918	.4786	3.2	1.445	2.089	.3388	.1148	9.4	2.951	8.710
.6839	.4677	3.3	1.462	2.138	.3350	.1122	9.5	2.985	8.913
.6761	.4571	3.4	1.479	2.188	.3311	.1096	9.6	3.020	9.120
.6683	.4467	3.5	1.496	2.239	.3273	.1072	9.7	3.055	9.333
.6607	.4365	3.6	1.514	2.291	.3236	.1047	9.8	3.090	9.550
.6531	.4266	3.7	1.531	2.344	.3199	.1023	9.9	3.126	9.772
.6457	.4169	3.8	1.549	2.399	.3162	.1000	10.0	3.162	10.000
.6383	.4074	3.9	1.567	2.455	.2985	.08913	10.5	3.350	11.22
.6310	.3981	4.0	1.585	2.512	.2818	.07943	11.0	3.548	12.59
.6237	.3890	4.1	1.603	2.570	.2661	.07079	11.5	3.758	14.13
.6166	.3802	4.2	1.622	2.630	.2512	.06310	12.0	3.981	15.85
.6095	.3715	4.3	1.641	2.692	.2371	.05623	12.5	4.217	17.78
.6026	.3631	4.4	1.660	2.754	.2239	.05012	13.0	4.467	19.95
.5957	.3548	4.5	1.679	2.818	.2113	.04467	13.5	4.732	22.39
.5888	.3467	4.6	1.698	2.884	.1995	.03981	14.0	5.012	25.12
.5821	.3388	4.7	1.718	2.951	.1884	.03548	14.5	5.309	28.18
.5754	.3311	4.8	1.738	3.020	.1778	.03162	15.0	5.623	31.62
.5689	.3236	4.9	1.758	3.090	.1585	.02512	16.0	6.310	39.81
.5623	.3162	5.0	1.778	3.162	.1413	.01995	17.0	7.079	50.12
.5559	.3090	5.1	1.799	3.236	.1259	.01585	18.0	7.943	63.10
.5495	.3020	5.2	1.820	3.311	.1122	.01259	19.0	8.913	79.43
.5433	.2951	5.3	1.841	3.388	.1000	.01000	20.0	10.000	100.00
.5370	.2884	5.4	1.862	3.467	.03162	.01000	30.0	31.620	1,000.00
.5309	.2818	5.5	1.884	3.548	.01	.00010	40.0	100.00	10,000.00
.5248	.2754	5.6	1.905	3.631	.003162	.00001	50.0	316.20	10 ⁵
.5188	.2692	5.7	1.928	3.715	.001	10 ⁻⁴	60.0	1,000.00	10 ⁶
.5129	.2630	5.8	1.950	3.802	.0003162	10 ⁻⁵	70.0	3,162.00	10 ⁷
.5070	.2570	5.9	1.972	3.890	.0001	10 ⁻⁶	80.0	10,000.00	10 ⁸
.5012	.2512	6.0	1.995	3.931	.00003162	10 ⁻⁷	90.0	31,620.00	10 ⁹
.4955	.2455	6.1	2.018	4.074	10 ⁻⁸	10 ⁻¹⁰	100.0	10 ⁵	10 ¹⁰

Table of Values for Attenuator Network Formulas

db	Voltage or Current Ratio	B	C	D	E	db	Voltage or Current Ratio	B	C	D	E
1	.98855	.01147	86.360	.005756	86.857	27.0	.04668	95533	.046757	91448	.089515
2	.97724	.022763	42.931	.011512	43.426	27.5	.04426	95783	.044026	91907	.084490
.25	.97163	.028372	34.247	.014390	34.739	28.0	.039811	96019	.041461	92343	.079748
3	.96605	.034046	28.456	.017268	28.947	30.0	.031623	96838	.032655	93869	.063309
.4	.95499	.040008	21.219	.023022	21.707	32.0	.025119	97488	.025766	95099	.050209
5	.94406	.056939	16.876	.028774	17.362	33.0	.022371	97629	.024290	95367	.047454
.6	.93325	.065475	13.982	.034525	14.428	33.5	.022387	97761	.023905	95621	.044797
7	.92257	.074429	11.915	.040274	12.395	34.0	.019953	98005	.020359	95888	.039921
.75	.91278	.082724	11.088	.043147	11.567	35.0	.017783	98222	.018105	96506	.035577
8	.90151	.089789	10.365	.046019	10.842	36.0	.015849	98415	.016104	96880	.031706
.9	.89125	.096849	9.1596	.051762	9.6337	37.5	.013335	98666	.013515	97368	.026675
1.0	.88140	.10580	8.1955	.057501	8.6667	38.0	.012589	98741	.012750	97513	.025183
1.5	.84140	.15860	5.3050	.086133	5.7619	39.0	.011020	98878	.011348	97781	.022443
2.0	.79433	.20567	3.8621	.11462	4.3048	40.0	.010000	99000	.010101	98020	.020002
2.5	.74989	.25011	2.9883	.14293	3.4268	42.0	.0079433	99206	.0080069	98424	.018888
3.0	.70795	.29205	2.4240	.17100	2.8385	42.5	.0074989	99250	.0073596	98511	.014999
3.5	.66834	.33166	2.0152	.19879	2.4158	44.0	.0063096	99369	.0063456	98746	.012620
4.0	.63096	.36904	1.7097	.22627	2.0966	45.0	.0056234	99438	.0056552	98882	.011247
4.5	.59566	.40434	1.4732	.25340	1.8465	47.5	.0042170	99578	.0042348	99160	.0084341
5.0	.56234	.43766	1.2849	.28013	1.6448	48.0	.0039811	99602	.0039970	99207	.0079623
6.0	.50119	.49881	1.0048	.33228	1.3386	50.0	.0031623	99684	.0031723	99370	.0063246
7.0	.44668	.55332	.80728	.38247	1.1160	51.0	.0028184	99718	.0028264	99438	.0059368
7.5	.42170	.57830	.72920	.40677	1.0258	52.0	.0025119	99749	.0025182	99499	.0050238
8.0	.39811	.60189	.66143	.43051	.94617	54.0	.0019953	99800	.0019993	99602	.0039905
9.0	.35481	.64519	.54994	.47622	.8183	55.0	.0017783	99822	.0017815	99645	.0035566
10.0	.31623	.68377	.46248	.51949	.70273	56.0	.0015849	99842	.0015874	99684	.0031598
11.0	.28184	.71816	.39244	.56026	.61231	57.0	.0014125	99859	.0014145	99718	.0028251
12.0	.25119	.74881	.33545	.59848	.53621	60.0	.0010000	99900	.0010010	99800	.0020000
12.5	.23714	.76286	.31085	.61664	.50253	64.0	.00063096	99937	.00063136	99874	.0012619
13.0	.22387	.77613	.28845	.63416	.47137	65.0	.00056234	99944	.00056266	99888	.0011247
13.0	.22387	.77613	.28845	.63416	.47137	66.0	.00050119	99950	.00050144	99900	.0010024
14.0	.19953	.80047	.24926	.66732	.41560	68.0	.00039811	99960	.00039827	99920	.0007962
15.0	.17783	.82217	.21629	.69804	.36727	70.0	.00031623	99968	.00031633	99937	.0006625
16.0	.15849	.84151	.18834	.72639	.32515	72.0	.00025119	99975	.00025125	99950	.0005024
17.0	.14125	.85875	.16449	.75468	.28826	75.0	.00017783	99982	.00017786	99964	.0003557
17.5	.13335	.86665	.15387	.76468	.27153	76.0	.00015849	99984	.00015851	99968	.0003170
18.0	.12589	.87411	.14402	.77637	.25584	78.0	.00012589	99987	.00012591	99975	.0002518
19.0	.11220	.88780	.12638	.79823	.22726	80.0	.00010000	99990	.00010000	99980	.0002000
20.0	.10000	.90000	.11111	.81818	.20202	84.0	.00006310	99994	.00006310	99987	.0001262
21.0	.089125	.91087	.097846	.83634	.17968	85.0	.00005624	99994	.00005624	99989	.0001125
22.0	.079433	.92051	.086282	.85282	.15987	90.0	.00003162	99997	.00003162	99994	.00006325
22.5	.074989	.92500	.081069	.86048	.15083	95.0	.00001778	99998	.00001778	99996	.00003557
24.0	.063096	.93690	.067345	.88130	.12670	98.0	.00001585	99998	.00001585	99997	.00003170
25.0	.056234	.94377	.059585	.89352	.11283	100.0	.00001000	99999	.00001000	99999	.00002000
26.0	.050119	.94988	.052763	.90455	.10049						

Attenuator Networks

For Insertion Between Equal Impedances

For data covering networks between unequal impedances, see Minimum Loss Pads on page 10. See also Decibel—Voltage Current and Power Ratio Table on page 6.

See table on page 7 for values of A, B, C, D, E used in the following attenuator network formulas.

In the case of L and U networks where only the input or output can be matched, as required, the matched side is indicated by an arrow pointing toward the pad. On all other networks, both the input and output circuits are matched.

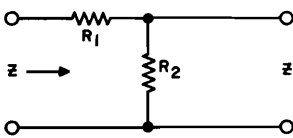
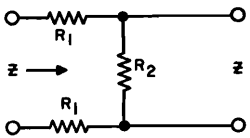
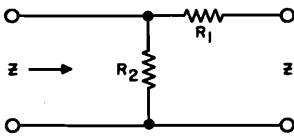
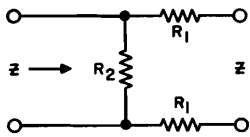
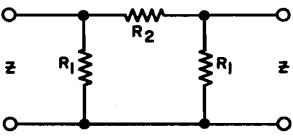
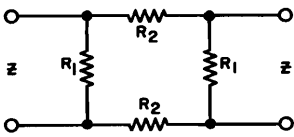
 <div style="text-align: center; margin-top: 20px;"> $R_1 = ZB$ $R_2 = ZC$ </div> <p style="text-align: center; margin-top: 10px;">L</p>	 <div style="text-align: center; margin-top: 20px;"> $R_1 = \frac{ZB}{2}$ $R_2 = ZC$ </div> <p style="text-align: center; margin-top: 10px;">U</p>
 <div style="text-align: center; margin-top: 20px;"> $R_1 = \frac{Z}{C}$ $R_2 = \frac{Z}{B}$ </div> <p style="text-align: center; margin-top: 10px;">L</p>	 <div style="text-align: center; margin-top: 20px;"> $R_1 = \frac{Z}{2C}$ $R_2 = \frac{Z}{B}$ </div> <p style="text-align: center; margin-top: 10px;">U</p>
 <div style="text-align: center; margin-top: 20px;"> $R_1 = \frac{Z}{D}$ $R_2 = \frac{Z}{E}$ </div> <p style="text-align: center; margin-top: 10px;">π</p>	 <div style="text-align: center; margin-top: 20px;"> $R_1 = \frac{Z}{D}$ $R_2 = \frac{Z}{2E}$ </div> <p style="text-align: center; margin-top: 10px;">O</p>

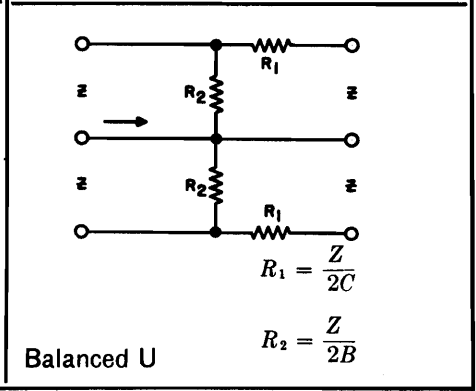
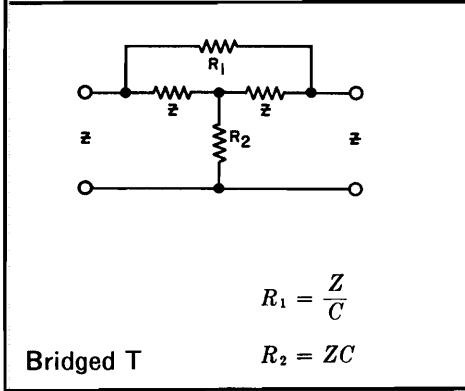
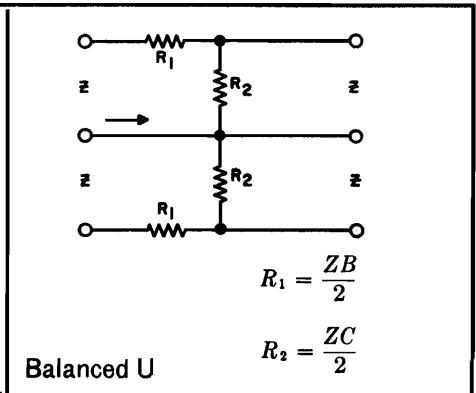
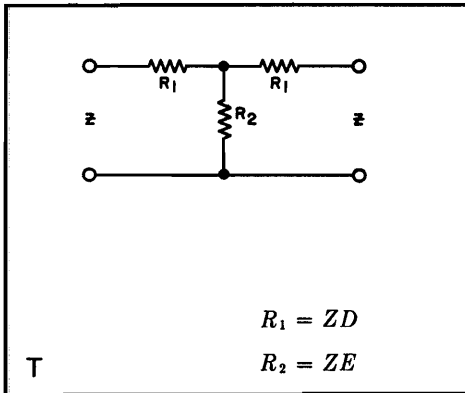

Constant Impedance Attenuators in Parallel

Table of R_1 Values in Ohms

Z	Number of Channels				
	2	3	4	5	6
30	10	15	18	20	21.5
50	16.6	25	30	33.3	35.7
150	50	75	90	100	107
200	66.6	100	120	133	143
250	83.3	125	150	166	179
500	166	250	300	333	357
600	200	300	360	400	428
Network db Loss	6	9.5	12	14	15.5

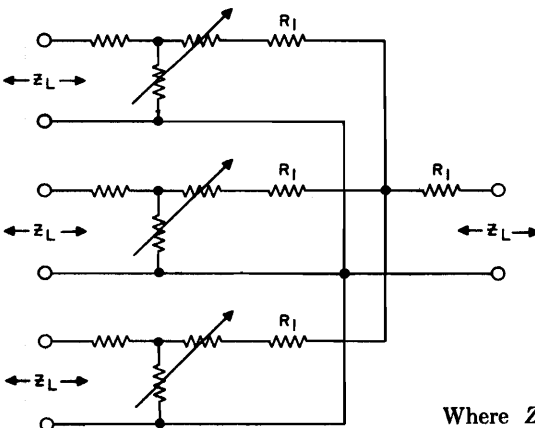

$$R_1 = Z_L \left(\frac{N-1}{N+1} \right) \quad \left| \quad \begin{array}{l} \text{Insertion loss} \\ \text{in db} = 20 \log_{10} N \end{array} \right.$$

Where Z_L = identical line and load impedances;
and N = number of channels in parallel.

Minimum Loss Pads

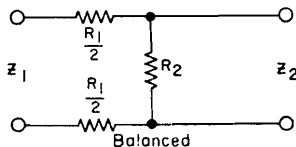
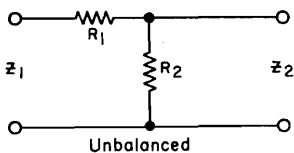

For Matching Two Impedances where $Z_1 > Z_2$

$$R_1 = \sqrt{Z_1 (Z_1 - Z_2)}$$

$$R_2 = \frac{Z_1 Z_2}{R_1}$$

$$db \text{ loss} = 20 \log_{10} \left(\sqrt{\frac{Z_1}{Z_2}} + \sqrt{\frac{Z_1}{Z_2} - 1} \right)$$

Where Only One Impedance is to be Matched

If the larger impedance only is to be

matched, use a resistor R_L in series with the smaller impedance such that

$$R_L = Z_1 - Z_2$$

$$db \text{ loss} = 20 \log_{10} \sqrt{\frac{Z_1}{Z_2}}$$

If the smaller impedance only is to be matched, use a resistor R_S in shunt across the larger impedance such that

$$R_S = \frac{Z_1 Z_2}{Z_1 - Z_2}$$

Here also $db \text{ loss} = 20 \log_{10} \sqrt{\frac{Z_1}{Z_2}}$

Tables of R_1 and R_2 Values

When Z_1 is 600 ohms and Z_2 is less than 600 ohms.

Z_2	500	400	300	250	200	150	100	75	50	40	30	25
R_1	245	346	424	458	490	520	548	561	575	580	585	587
R_2	1,225	694	425	328	245	173	110	80.2	52.2	41.4	30.8	25.6
db Loss	3.8	5.7	7.6	8.7	10.0	11.4	13.4	14.8	16.6	17.6	18.9	19.7

When Z_2 is less than 25 ohms,

$$\text{let } R_1 = 600 - \frac{Z_1}{Z_2}$$

$$\text{and } R_2 = Z_2$$

Where Z_2 is 600 ohms, and Z_1 is greater than 600 ohms.

Z_1	800	1,000	1,200	1,500	2,000	2,500	3,000	3,500	4,000	5,000	6,000	8,000	10,000
R_1	400	632	849	1,162	1,673	2,180	2,683	3,186	3,688	4,690	5,692	7,694	9,695
R_2	1,200	949	849	775	717	688	671	659	651	638	633	624	619
db Loss	4.8	6.5	7.6	9.0	10.5	11.6	12.5	13.3	13.9	15.0	15.8	17.1	18.1

When Z_1 is greater than 10,000 ohms,

$$\text{let } R_1 = Z_1 - 300$$

$$\text{and } R_2 = 600$$

70-Volt Loud-Speaker Matching Systems

The EIA 70.7 volt constant voltage system of power distribution provides the engineer and technician with a simple means of matching a number of loudspeakers to an amplifier. To use this method:

1. Determine the power required at each loudspeaker.
2. Add the powers required for the individual speakers and select an amplifier with a rated power output equal to or greater than this total.
3. Select 70.7-volt transformers having primary wattage taps as determined in step 1.*
4. Wire the selected primaries in parallel across the 70.7-volt line.
5. Connect each secondary to its speaker; selecting the tap which matches the voice coil impedance.

For transformers rated in impedance, the following formulas may be used to determine the proper taps in step 3.

$$\text{Primary Impedance} = \frac{(\text{Amplifier output voltage})^2}{\text{Desired speaker power}}$$

or
$$Z = \frac{E^2}{P} \quad (1)$$

*These transformers have the primary taps marked in watts and the secondaries marked in ohms.

Since the voltage at rated amplifier power is 70.7, this reduces to:

$$Z = \frac{70.7^2}{P} = \frac{5000}{P} \quad (2)$$

From formula (2) these relationships are:

- 1 watt requires 5000 ohm primary
- 2 watts requires 2500 ohm primary
- 5 watts requires 1000 ohm primary
- 10 watts requires 500 ohm primary

Once the primary taps have been determined, continue on through step 4 and 5 as outlined above. When selecting transformer primary taps, use the next highest available value above the computed value. A mismatch of 25% is generally considered permissible.

Example: Required

One 6 watt speaker with 4 ohm voice coil.
Two 10 watt speakers with 8 ohm voice coils (use one transformer at this location).

(1-2) Total power = 6 + 10 + 10 = 26 watts (use a 30-watt amplifier or other amplifier capable of handling at least 26 watts)

(3) $Z_{6 \text{ watts}} = \frac{5000}{6} = 833 \text{ ohms}$ (use 1000 ohm transformer)

$Z_{20 \text{ watts}} = \frac{5000}{20} = 250 \text{ ohms}$

(4-5) See sketch below.

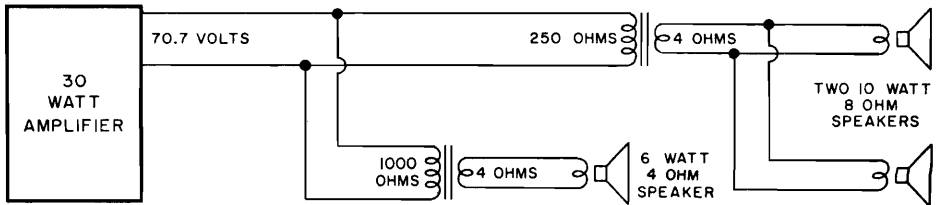

Most Used Formulas

Resistance Formulas

In series $R_t = R_1 + R_2 + R_3 \dots \text{etc.}$

In parallel $R_t = \frac{1}{\frac{1}{R_1} + \frac{1}{R_2} + \frac{1}{R_3} \dots \text{etc.}}$

Two resistors in parallel $R_t = \frac{R_1 R_2}{R_1 + R_2}$

Capacitance

In parallel $C_t = C_1 + C_2 + C_3 \dots \text{etc.}$

In series $C_t = \frac{1}{\frac{1}{C_1} + \frac{1}{C_2} + \frac{1}{C_3} \dots \text{etc.}}$

Two capacitors in series $C_t = \frac{C_1 C_2}{C_1 + C_2}$

The Quantity of Electricity Stored Within a Capacitor is Given by

$$Q = CE$$

where Q = the quantity stored, in coulombs,

E = the potential impressed across the capacitor in volts,

C = capacitance in farads.

The Capacitance of a Parallel Plate Capacitor is Given by

$$C = 0.0885 \frac{KS(N-1)}{d}$$

where C = capacitance in mmfd.,

K = dielectric constant,

* S = area of one plate in square centimeters,

N = number of plates,

* d = thickness of the dielectric in centimeters (same as the distance between plates).

* When S and d are given in inches, change constant 0.0885 to 0.224. Answer will still be in micromicrofarads.

DIELECTRIC CONSTANTS

<i>Kind of Dielectric</i>	<i>Approximate* K Value</i>
Air (at atmospheric pressure).....	1.0
Bakelite.....	5.0
Beeswax.....	3.0
Cambric (varnished).....	4.0
Fibre (Red).....	5.0
Glass (window or flint).....	8.0
Gutta Percha.....	4.0
Mica.....	6.0
Paraffin (solid).....	2.5
Paraffin Coated Paper.....	3.5
Porcelain.....	6.0
Pyrex.....	4.5
Quartz.....	5.0
Rubber.....	3.0
Slate.....	7.0
Wood (very dry).....	5.0

* These values are approximate, since true values depend upon quality or grade of material used, as well as moisture content, temperature and frequency characteristics of each.

Self-Inductance

In series $L_t = L_1 + L_2 + L_3 \dots \text{etc.}$

In parallel $L_t = \frac{1}{\frac{1}{L_1} + \frac{1}{L_2} + \frac{1}{L_3} \dots \text{etc.}}$

Two inductors in parallel $L_t = \frac{L_1 L_2}{L_1 + L_2}$

Coupled Inductance

In series with fields *aiding*

$$L_t = L_1 + L_2 + 2M$$

In series with fields *opposing*

$$L_t = L_1 + L_2 - 2M$$

In parallel with fields *aiding*

$$L_t = \frac{1}{\frac{1}{L_1 + M} + \frac{1}{L_2 + M}}$$

In parallel with fields *opposing*

$$L_t = \frac{1}{\frac{1}{L_1 - M} + \frac{1}{L_2 - M}}$$

where L_t = the total inductance,
 M = the mutual inductance,
 L_1 and L_2 = the self inductance of the individual coils.

Mutual Inductance

The mutual inductance of two r-f coils with fields interacting, is given by

$$M = \frac{L_A - L_O}{4}$$

where M = mutual inductance, expressed in same units as L_A and L_O ,
 L_A = Total inductance of coils L_1 and L_2 with fields *aiding*,
 L_O = Total inductance of coils L_1 and L_2 with fields *opposing*.

Coupling Coefficient

When two r-f coils are inductively coupled so as to give transformer action, the coupling coefficient is expressed by

$$K = \frac{M}{\sqrt{L_1 L_2}}$$

where K = the coupling coefficient;
 $(K \times 10^2 =$ coupling coefficient in %),

M = the mutual inductance value,
 L_1 and L_2 = the self-inductance of the two coils respectively, both being expressed in the same units.

Resonance

The resonant frequency, or frequency at which inductive reactance X_L equals capacitive reactance X_C , is expressed by

$$f_r = \frac{1}{2\pi \sqrt{LC}}$$

also $L = \frac{1}{4\pi^2 f_r^2 C}$

and $C = \frac{1}{4\pi^2 f_r^2 L}$

where f_r = resonant frequency in cycles per second,
 L = inductance in henrys,
 C = capacitance in farads,
 $2\pi = 6.28$
 $4\pi^2 = 39.5$

Reactance

of an inductance is expressed by

$$X_L = 2\pi fL$$

of a capacitance is expressed by

$$X_C = \frac{1}{2\pi fC}$$

where X_L = inductive reactance in ohms, (known as positive reactance),
 X_C = capacitive reactance in ohms, (known as negative reactance),

f = frequency in cycles per second,
 L = inductance in henrys,
 C = capacitance in farads,
 $2\pi = 6.28$

Frequency from Wavelength

$$f = \frac{3 \times 10^5}{\lambda} \text{ (kilocycles)}$$

where λ = wavelength in *meters*.

$$f = \frac{3 \times 10^4}{\lambda} \text{ (megacycles)}$$

where λ = wavelength in *centimeters*.

Wavelength from Frequency

$$\lambda = \frac{3 \times 10^5}{f} \text{ (meters)}$$

where f = frequency in *kilocycles*.

$$\lambda = \frac{3 \times 10^4}{f} \text{ (centimeters)}$$

where f = frequency in *megacycles*.

Q or Figure of Merit

of a simple reactor

$$Q = \frac{X_L}{R_L}$$

of a single capacitor

$$Q = \frac{X_C}{R_C}$$

where Q = a ratio expressing the figure of merit,

X_L = inductive reactance in ohms,

X_C = capacitive reactance in ohms,

R_L = resistance in ohms acting in series with inductance,

R_C = resistance in ohms acting in series with capacitance,

Impedance

In any a-c circuit where resistance and reactance values of the R , L and C components are given, the absolute or numerical magnitude of impedance and phase angle can be computed from the formulas which follow.

In general the basic formulas expressing total impedance are:

for series circuits,

$$Z_t = \sqrt{R_t^2 + X_t^2},$$

for parallel circuits,

$$Z_t = \frac{1}{\sqrt{G_t^2 + B_t^2}}$$

See page 17 for formulas involving impedance, conductance, susceptance and admittance.

In series circuits where phase angle and any two of the Z , R and X components are known, the unknown component may be determined from the expressions:

$$Z = \frac{R}{\cos \theta} \qquad Z = \frac{X}{\sin \theta}$$

$$R = Z \cos \theta \qquad X = Z \sin \theta$$

where Z = magnitude of impedance in ohms,

R = resistance in ohms,

X = reactance (inductive or capacitive) in ohms.

Nomenclature

Z = absolute or numerical value of impedance magnitude in ohms

R = resistance in ohms,

X_L = inductive reactance in ohms,

X_C = capacitive reactance in ohms,

L = inductance in henrys,

C = capacitance in farads,

R_L = resistance in ohms acting in series with inductance,

R_C = resistance in ohms acting in series with capacitance,

θ = phase angle in degrees by which current leads voltage in a capacitive circuit, or lags voltage in an inductive circuit. In a resonant circuit, where X_L equals X_C , θ equals 0° .

Degrees \times 0.0175 = radians.

1 radian = 57.3° .

Numerical Magnitude of Impedance . . .



of resistance alone

$$Z = R$$

$$\theta = 0^\circ$$

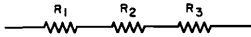

of resistance in series

$$Z = R_1 + R_2 + R_3 \dots \text{etc.}$$

$$\theta = 0^\circ$$

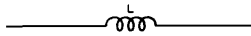

of inductance alone

$$Z = X_L$$

$$\theta = +90^\circ$$

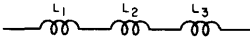

of inductance in series

$$Z = X_{L1} + X_{L2} + X_{L3} \dots \text{etc.}$$

$$\theta = +90^\circ$$

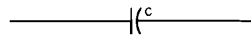

of capacitance alone

$$Z = X_C$$

$$\theta = -90^\circ$$

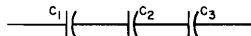

of capacitance in series

$$Z = X_{C1} + X_{C2} + X_{C3} \dots \text{etc.}$$

$$\theta = -90^\circ$$

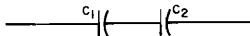

or where only 2 capacitances C_1 and C_2 are involved,

$$Z = \frac{1}{2\pi f} \left(\frac{C_1 + C_2}{C_1 C_2} \right)$$

$$\theta = -90^\circ$$

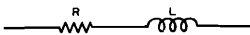

of resistance and inductance in series

$$Z = \sqrt{R^2 + X_L^2}$$

$$\theta = \text{arc tan } \frac{X_L}{R}$$

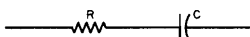

of resistance and capacitance in series

$$Z = \sqrt{R^2 + X_C^2}$$

$$\theta = \text{arc tan } \frac{X_C}{R}$$

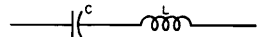

of inductance and capacitance in series

$$Z = X_L - X_C$$

$$\theta = -90^\circ \text{ when } X_L < X_C$$

$$= 0^\circ \text{ when } X_L = X_C$$

$$= +90^\circ \text{ when } X_L > X_C$$

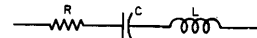

of resistance, inductance and capacitance in series

$$Z = \sqrt{R^2 + (X_L - X_C)^2}$$

$$\theta = \text{arc tan } \frac{X_L - X_C}{R}$$

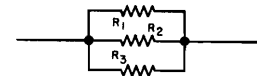

of resistance in parallel

$$Z = \frac{1}{\frac{1}{R_1} + \frac{1}{R_2} + \frac{1}{R_3} \dots \text{etc.}}$$

$$\theta = 0^\circ$$

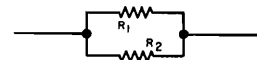

or where only 2 resistances R_1 and R_2 are involved,

$$Z = \frac{R_1 R_2}{R_1 + R_2}$$

$$\theta = 0^\circ$$

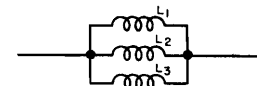

of inductance in parallel

$$Z = \frac{1}{\frac{1}{X_{L1}} + \frac{1}{X_{L2}} + \frac{1}{X_{L3}} \dots \text{etc.}}$$

$$\theta = +90^\circ$$

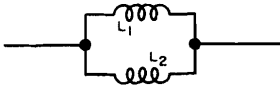

or where only 2 inductances L_1 and L_2 are involved,

$$Z = 2\pi f \left(\frac{L_1 L_2}{L_1 + L_2} \right)$$

$$\theta = +90^\circ$$

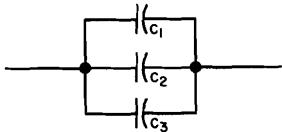

of capacitance in parallel

$$Z = \frac{1}{\frac{1}{X_{C1}} + \frac{1}{X_{C2}} + \frac{1}{X_{C3}} \dots \text{etc.}}$$

$$\theta = -90^\circ$$

or where only 2 capacitances C_1 and C_2 are involved,

$$Z = \frac{1}{2\pi f (C_1 + C_2)}$$

$$\theta = -90^\circ$$

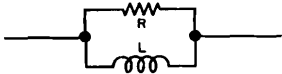

of inductance and resistance in parallel,

$$Z = \frac{RX_L}{\sqrt{R^2 + X_L^2}}$$

$$\theta = \arctan \frac{R}{X_L}$$

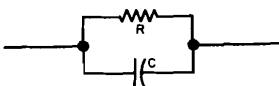

of capacitance and resistance in parallel,

$$Z = \frac{RX_C}{\sqrt{R^2 + X_C^2}}$$

$$\theta = -\arctan \frac{R}{X_C}$$

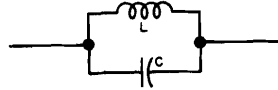

of inductance and capacitance in parallel,

$$Z = \frac{X_L X_C}{X_L - X_C}$$

$$\theta = 0^\circ \text{ when } X_L = X_C$$

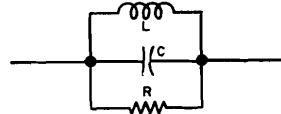

of inductance, resistance and capacitance in parallel

$$Z = \frac{RX_L X_C}{\sqrt{X_L^2 X_C^2 + (RX_L - RX_C)^2}}$$

$$\theta = \arctan \frac{RX_C - RX_L}{X_L X_C}$$

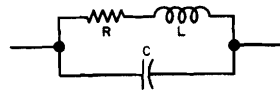

of inductance and series resistance in parallel with capacitance

$$Z = X_C \sqrt{\frac{R^2 + X_L^2}{R^2 + (X_L - X_C)^2}}$$

$$\theta = \arctan \left(\frac{X_L X_C - X_L^2 - R^2}{RX_C} \right)$$

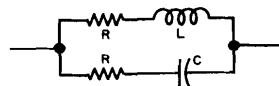

of capacitance and series resistance in parallel with inductance and series resistance

$$Z = \sqrt{\frac{(R_L^2 + X_L^2)(R_C^2 + X_C^2)}{(R_L + R_C)^2 + (X_L - X_C)^2}}$$

$$\theta = \arctan \frac{X_L(R_C^2 + X_C^2) - X_C(R_L^2 + X_L^2)}{R_L(R_C^2 + X_C^2) + R_C(R_L^2 + X_L^2)}$$

Conductance

In direct current circuits, conductance is expressed by

$$G = \frac{1}{R}$$

where G = conductance in mhos,
 R = resistance in ohms.

In d-c circuits involving resistances R_1, R_2, R_3 , etc., in parallel,

the total conductance is expressed by

$$G_{\text{total}} = G_1 + G_2 + G_3 \dots \text{etc.}$$

and the total current by

$$I_{\text{total}} = E G_{\text{total}}$$

and the amount of current in any single resistor, R_2 for example, in a parallel group, by

$$I_2 = \frac{I_{\text{total}} G_2}{G_1 + G_2 + G_3 \dots \text{etc.}}$$

R, E and I in Ohm's law formulas for d-c circuits may be expressed in terms of conductance as follows:

$$R = \frac{1}{G}, \quad E = \frac{I}{G}, \quad I = EG,$$

where G = conductance in mhos,
 R = resistance in ohms,
 E = potential in volts,
 I = current in amperes.

Susceptance

In an alternating current circuit, the susceptance of a series circuit is expressed by

$$B = \frac{X}{R^2 + X^2}$$

or, when the resistance is 0, susceptance becomes the reciprocal of reactance, or

$$B = \frac{1}{X}$$

where B = susceptance in mhos,
 R = resistance in ohms,
 X = reactance in ohms.

Admittance

In an alternating current circuit, the admittance of a series circuit is expressed by

$$Y = \frac{1}{\sqrt{R^2 + X^2}}$$

Admittance is also expressed as the reciprocal of impedance, or

$$Y = \frac{1}{Z}$$

where Y = admittance in mhos,
 R = resistance in ohms,
 X = reactance in ohms,
 Z = impedance in ohms.

R and X in Terms of G and B

Resistance and reactance may be expressed in terms of conductance and susceptance as follows:

$$R = \frac{G}{G^2 + B^2}, \quad X = \frac{B}{G^2 + B^2}.$$

G, B, Y and Z in Parallel Circuits

In any given a-c circuit containing a number of smaller parallel circuits only,

the effective conductance G_t is expressed by

$$G_t = G_1 + G_2 + G_3 \dots \text{etc.},$$

and the effective susceptance B_t by

$$B_t = B_1 + B_2 + B_3 \dots \text{etc.}$$

and the effective admittance Y_t by

$$Y_t = \sqrt{G_t^2 + B_t^2}$$

and the effective impedance Z_t by

$$Z_t = \frac{1}{\sqrt{G_t^2 + B_t^2}} \text{ or } \frac{1}{Y_t}$$

where R = resistance in ohms,
 X = reactance (capacitive or inductive) in ohms,
 G = conductance in mhos,
 B = susceptance in mhos,
 Y = admittance in mhos,
 Z = impedance in ohms.

Transient *I* and *E* in LCR Circuits

The formulas which follow may be used to closely approximate the growth and decay of current and voltage in circuits involving *L*, *C* and *R*:

- where *i* = instantaneous current in amperes at any given time (*t*),
- E* = potential in volts as designated,
- R* = circuit resistance in ohms,
- C* = capacitance in farads,
- L* = inductance in henrys,
- V* = steady state potential in volts,
- V_C* = reactive volts across *C*,
- V_L* = reactive volts across *L*,
- V_R* = voltage across *R*

RC = time constant of *RC* circuit in seconds,

$\frac{L}{R}$ = time constant of *RL* circuit in seconds,

t = any given time in seconds after switch is thrown,

ϵ = a constant, 2.718 (base of the natural system of logarithms),

Sw = switch

The **time constant** is defined as the time in seconds for current or voltage to fall to $\frac{1}{\epsilon}$ or 36.8% of its initial value or to rise to $(1 - \frac{1}{\epsilon})$ or approximately 63.2% of its final value.

Charging a De-energized Capacitive Circuit

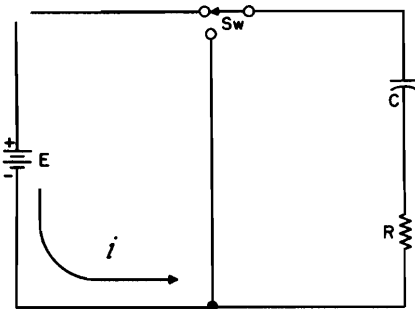

E = applied potential.

$$i = \frac{E}{R} \epsilon^{-\frac{t}{RC}}$$

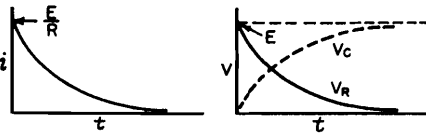

$$V_C = E \left(1 - \epsilon^{-\frac{t}{RC}} \right) \quad V_R = E \epsilon^{-\frac{t}{RC}}$$

Discharging an Energized Capacitive Circuit

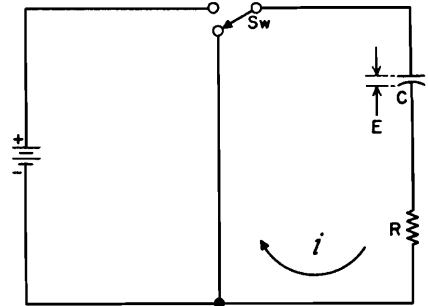

E = potential to which *C* is charged prior to closing *Sw*.

$$i = \frac{E}{R} \epsilon^{-\frac{t}{RC}}$$

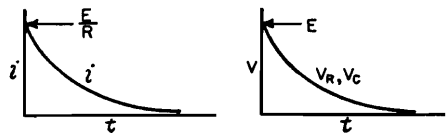

$$V_C = V_R = E \epsilon^{-\frac{t}{RC}}$$

Voltage is Applied to a De-energized Inductive Circuit

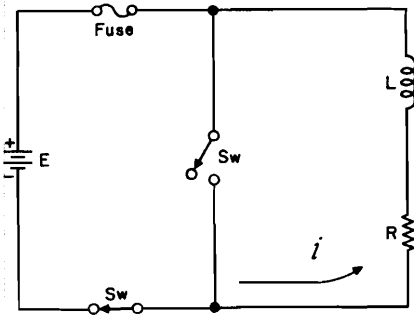

$E =$ applied potential

$$i = \frac{E}{R} \left(1 - e^{-\frac{Rt}{L}} \right)$$

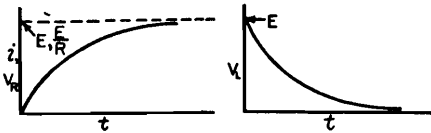

$$V_R = E \left(1 - e^{-\frac{Rt}{L}} \right)$$

$$V_L = E e^{-\frac{Rt}{L}}$$

An Energized Inductive Circuit is Short Circuited

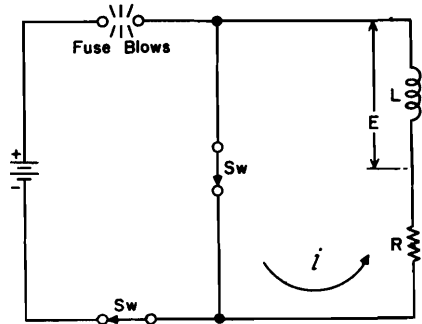

$E =$ counter potential induced in coil when switch is closed.

$$i = \frac{E}{R} e^{-\frac{Rt}{L}}$$

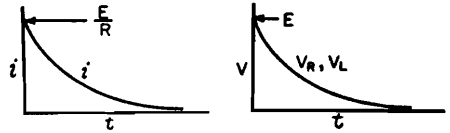

$$V_L = V_R = E e^{-\frac{Rt}{L}}$$

Steady State Current Flow

In a Capacitive Circuit

In a capacitive circuit, where resistance loss components may be considered as negligible, the flow of current at a given alternating potential of constant frequency, is expressed by

$$I = \frac{E}{X_C} = \frac{E}{\left(\frac{1}{2\pi fC} \right)} = E (2\pi fC)$$

where $I =$ current in amperes,
 $X_C =$ capacitive reactance of the circuit in ohms,
 $E =$ applied potential in volts.

In an Inductive Circuit

In an inductive circuit, where inherent resistance and capacitance components may be so low as to be negligible, the flow of current at a given alternating potential of a constant frequency, is expressed by

$$I = \frac{E}{X_L} = \frac{E}{2\pi fL}$$

where $I =$ current in amperes,
 $X_L =$ inductive reactance of the circuit in ohms,
 $E =$ applied potential in volts.

Transmission Line Formulas

Concentric Transmission Lines

Characteristic impedance in ohms is given by

$$Z = 138 \log \frac{d_1}{d_2}$$

R-f resistance in ohms per foot of copper line, is given by

$$r = \sqrt{f} \left(\frac{1}{d_1} + \frac{1}{d_2} \right) \times 10^{-3}$$

Attenuation in decibels per foot of line, is given by

$$a = \frac{4.6\sqrt{f}(d_1 + d_2)}{d_1 d_2 \left(\log \frac{d_1}{d_2} \right)} \times 10^{-6}$$

where Z = characteristic impedance in ohms,

r = radio frequency resistance in ohms per foot of *copper line*,

a = attenuation in decibels per foot of *line*,

d_1 = the *inside* diameter of the *outer conductor*, expressed in inches,

d_2 = the *outside* diameter of the *inner conductor*, expressed in inches,

f = frequency in megacycles.

Two-Wire Open Air Transmission Lines

Characteristic impedance in ohms is given by

$$Z = 276 \left(\log \frac{2D}{d} \right)$$

Inductance in microhenrys per foot of *line* is given by

$$L = 0.281 \left(\log \frac{2D}{d} \right)$$

Capacitance in micromicrofarads per foot of *line* is given by

$$C = \frac{3.68}{\log \frac{2D}{d}}$$

Attenuation in decibels per foot of *wire* is given by

$$db = \frac{0.0157 R_f}{\log \frac{2D}{d}}$$

R-f resistance in Ohms per loop-foot of *wire*, is given by

$$R_f = \frac{2 \times 10^{-3} \sqrt{f}}{d}$$

where Z = characteristic impedance in ohms,

D = spacing between wire centers in inches,

d = the diameter of the conductors in inches,

L = inductance in microhenrys per foot of *line*,

C = capacitance in micromicrofarads per foot of *line*,

db = attenuation in decibels per foot of *wire*,

R_f = r-f resistance in ohms per loop-foot of *wire*,

f = frequency in megacycles.

Vertical Antenna

The capacitance of a vertical antenna, shorter than one-quarter wave length at its operating frequency, is given by

$$C_a = \frac{17l}{\left[\left(\log \epsilon \frac{24l}{d} \right) - 1 \right] \left[1 - \left(\frac{fl}{246} \right)^2 \right]}$$

where C_a = capacitance of the antenna in micromicrofarads,

l = height of antenna in feet,

d = diameter of antenna conductor in inches,

f = operating frequency in megacycles,

ϵ = 2.718 (the base of the natural system of logarithms).

Trigonometric Relationships

In any right triangle, if we let

θ = the acute angle formed by the hypotenuse and the base leg,

ϕ = the acute angle formed by the hypotenuse and the altitude leg,

H = the hypotenuse,

A = the side adjacent θ and opposite ϕ ,

O = the side opposite θ and adjacent ϕ ,

then $\text{sine of } \theta = \sin \theta = \frac{O}{H}$

$\text{cosine of } \theta = \cos \theta = \frac{A}{H}$

$\text{tangent of } \theta = \tan \theta = \frac{O}{A}$

$\text{cosecant of } \theta = \csc \theta = \frac{H}{O}$

$\text{secant of } \theta = \sec \theta = \frac{H}{A}$

$\text{cotangent of } \theta = \cot \theta = \frac{A}{O}$

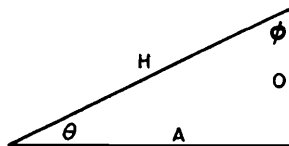

also $\sin \theta = \cos \phi$ $\csc \theta = \sec \phi$
 $\cos \theta = \sin \phi$ $\sec \theta = \csc \phi$
 $\tan \theta = \cot \phi$ $\cot \theta = \tan \phi$

and $\frac{1}{\sin \theta} = \csc \theta$ $\frac{1}{\csc \theta} = \sin \theta$
 $\frac{1}{\cos \theta} = \sec \theta$ $\frac{1}{\sec \theta} = \cos \theta$
 $\frac{1}{\tan \theta} = \cot \theta$ $\frac{1}{\cot \theta} = \tan \theta$

The expression "arc sin" indicates, "the angle whose sine is" . . . ; likewise arc tan indicates, "the angle whose tangent is" . . . etc. See formulas in table below.

Known Values	Formulas for Determining Unknown Values of . . .				
	A	O	H	θ	ϕ
A & O			$\sqrt{A^2 + O^2}$	$\text{arc tan } \frac{O}{A}$	$\text{arc tan } \frac{A}{O}$
A & H		$\sqrt{H^2 - A^2}$		$\text{arc cos } \frac{A}{H}$	$\text{arc sin } \frac{A}{H}$
A & θ		$A \tan \theta$	$\frac{A}{\cos \theta}$		$90^\circ - \theta$
A & ϕ		$\frac{A}{\tan \phi}$	$\frac{A}{\sin \phi}$	$90^\circ - \phi$	
O & H	$\sqrt{H^2 - O^2}$			$\text{arc sin } \frac{O}{H}$	$\text{arc cos } \frac{O}{H}$
O & θ	$\frac{O}{\tan \theta}$		$\frac{O}{\sin \theta}$		$90^\circ - \theta$
O & ϕ	$O \tan \phi$		$\frac{O}{\cos \phi}$	$90^\circ - \phi$	
H & θ	$H \cos \theta$	$H \sin \theta$			$90^\circ - \theta$
H & ϕ	$H \sin \phi$	$H \cos \phi$		$90^\circ - \phi$	

Vacuum Tube Formulas and Symbols

Vacuum Tube Constants

Amplification factor (Mu or μ) is given by

$$\mu = \frac{\Delta E_p}{\Delta E_g} \text{ (with } I_p \text{ constant)}$$

Dynamic plate resistance in ohms, is given by

$$r_p = \frac{\Delta E_p}{\Delta I_p} \text{ (with } E_g \text{ constant)}$$

Mutual conductance in mhos, is given by

$$g_m = \frac{\Delta I_p}{\Delta E_g} \text{ (with } E_p \text{ constant)}$$

Vacuum Tube Formulas

Gain per stage is given by

$$\mu \left(\frac{R_L}{R_L + r_p} \right)$$

Voltage output appearing in R_L is given by

$$\mu \left(\frac{E_s R_L}{r_p + R_L} \right)$$

Power output in R_L , is given by

$$R_L \left(\frac{\mu E_s}{r_p + R_L} \right)^2$$

Maximum power output in R_L which results when $R_L = r_p$, is given by

$$\frac{(\mu E_s)^2}{4r_p}$$

Maximum undistorted power output in R_L , which results when $R_L = 2r_p$, is given by

$$\frac{2(\mu E_s)^2}{9r_p}$$

Required cathode biasing resistor in ohms, for a single tube is given by

$$\frac{E_g}{I_k}$$

Vacuum Tube Symbols

Mu or μ = Amplification factor,

r_p = Dynamic plate resistance in ohms,

g_m = Mutual conductance in mhos,

E_p = Plate voltage in volts,

E_g = Grid voltage in volts,

I_p = Plate current in amperes,

R_L = Plate load resistance in ohms,

I_k = Total cathode current in amperes,

E_s = Signal voltage in volts,

Δ = change or variation in value, which may be either an increment (increase), or a decrement (decrease).

Peak, R.M.S., and Average A-C Values of E & I

Given Value	To get . . .		
	Peak	R.M.S.	Av.
Peak		$0.707 \times \text{Peak}$	$0.637 \times \text{Peak}$
R.M.S.	$1.41 \times \text{R.M.S.}$		$0.9 \times \text{R.M.S.}$
Av.	$1.57 \times \text{Av.}$	$1.11 \times \text{Av.}$	

Transistor Formulas and Symbols

Common Emitter Configuration

Transistors can be made to amplify, detect, or to oscillate in much the same manner as vacuum tubes. Shown in the drawings below is a comparison between a triode vacuum-tube and a PNP transistor; where the transistor

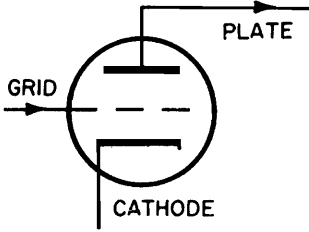

Triode Vacuum Tube

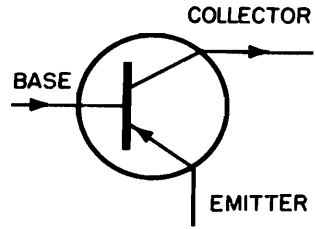

PNP Transistor

base is comparable to the tube grid, the transistor emitter is comparable to the tube cathode, and the transistor collector is comparable to the tube plate.

Transistor Formulas

Input Resistance,

$$R_i = \frac{\Delta V_i}{\Delta I_i}$$

Current Gain,

$$A_i = \frac{\Delta I_c}{\Delta I_b} \text{ (with } V_c \text{ constant)}$$

Voltage Gain,

$$A_v = \frac{\Delta V_c}{\Delta V_b} \text{ (with } I_c \text{ constant)}$$

Output Resistance,

$$R_o = \frac{\Delta V_o}{\Delta I_o}$$

Power Gain,

$$A_p = \frac{\Delta P_o}{\Delta P_i}$$

The current gain of the common base configuration is alpha, where

$$\alpha = \frac{\Delta I_c}{\Delta I_e} \text{ (with } V_c \text{ constant)}$$

The current gain of the common emitter is beta, where

$$\beta = \frac{\Delta I_c}{\Delta I_b} \text{ (with } V_c \text{ constant)}$$

Transistor Symbols

α = Current gain common base

A_v (A_v) = Voltage gain

A_i = Current gain

A = Power gain

B = Current gain common emitter

I_b = Base current

I_c = Collector current

I_e = Emitter current

I_i = Input current

P_i = Input power

P_o = Output power

R_i = Input resistance

R_o = Output resistance

V_b = Base voltage

V_c = Collector voltage

V_i = Input voltage

A direct relationship exists between the alpha and beta of a transistor.

$$\alpha = \frac{B}{1 + B} \quad B = \frac{\alpha}{1 - \alpha}$$

Transistor Amplifier Circuit Configurations

With Vacuum & Tube Counterparts

The transistors of primary interest to the radio engineer and service technician are the PNP and NPN junction types, whose transistor actions are identically alike, except that symbolically, the emitter arrow points towards the base in the PNP and away from the base in the NPN. The common-emitter circuits are used almost

exclusively for most amplification purposes as are the common or grounded-cathode vacuum tube circuits. The common-base and common-grid as well as common-collector common-plate circuits are used more for special applications such as impedance matching to and from audio transmission lines, etc.

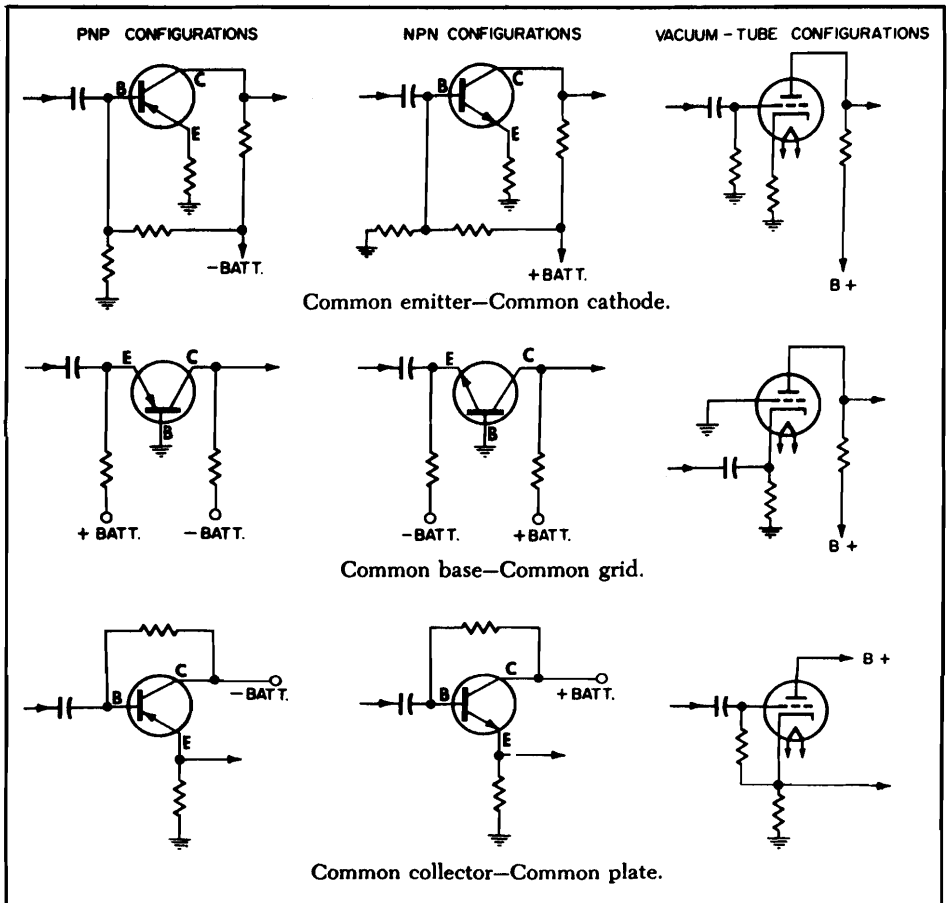

Common-Emitter Amplifier Circuits Using Transistors Only

In comparing the PNP and NPN circuits shown here, note that the current flow in the components of one is completely reversed in the other. With the vacuum tube, this complete interchange of current and voltage polarities does not exist. Because of

this interchange in the transistor, circuits which have no parallel in vacuum-tube circuitry can be produced. Nevertheless, the circuits of transistorized equipment are still quite similar in many respects to those of equipment employing vacuum tubes.

Using PNP Transistors

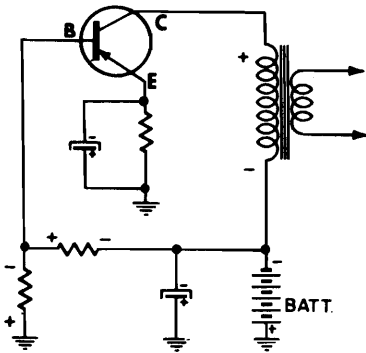

With Positive
Battery Terminal Grounded

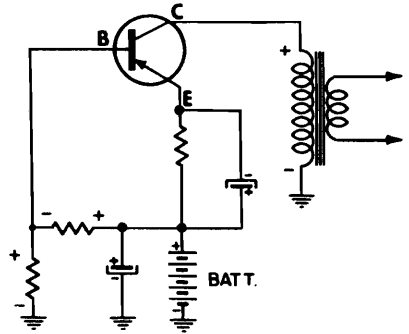

With Negative
Battery Terminal Grounded

Using NPN Transistors

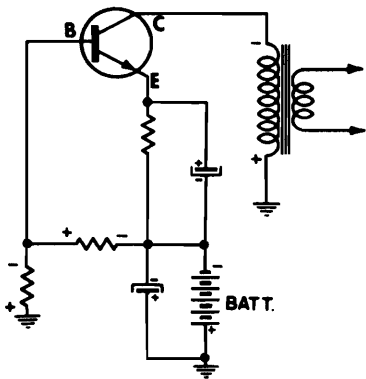

With Positive
Battery Terminal Grounded

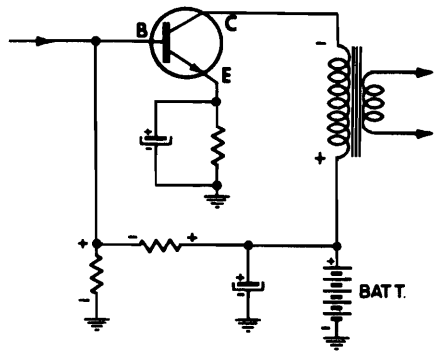

With Negative
Battery Terminal Grounded

D-C Meter Formulas

Meter Resistance

The d-c resistance of a milliammeter or voltmeter movement may be determined as follows:

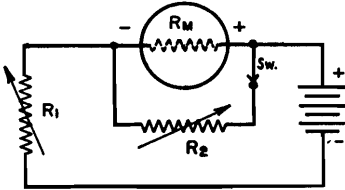

1. Connect the meter in series with a suitable battery and variable resistance R_1 as shown in the diagram above.
2. Vary R_1 until a full scale reading is obtained.
3. Connect another variable resistor R_2 across the meter and vary its value until a half scale reading is obtained.
4. Disconnect R_2 from the circuit and measure its d-c resistance.

The meter resistance R_m is equal to the measured resistance of R_2 .

Caution: Be sure that R_1 has sufficient resistance to prevent an off scale reading of the meter. The correct value depends upon the sensitivity of meter, and voltage of the battery. The following formula can be used if the full scale current of the meter is known:

$$R_1 = \frac{\text{voltage of the battery used}}{\text{full scale current of meter in amperes}}$$

For safe results, use twice the value computed. Also, never attempt to measure the resistance of a meter with an ohmmeter. To do so would in all probability result in a burned-out or severely damaged meter, since the current required for the operation of some ohmmeters and bridges is far in excess of the full scale current required by the movement of the average meter you may be checking.

Ohms per Volt Rating of a Voltmeter

$$\Omega/V = \frac{1}{I_{fs}}$$

where Ω/V = ohms per volt,

I_{fs} = full scale current in amperes.

Fixed Current Shunts

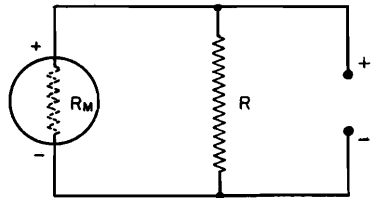

$$R = \frac{R_m}{N - 1}$$

R = shunt value in ohms,

N = the new full scale reading divided by the original full scale reading, both being stated in the same units,

R_m = meter resistance in ohms.

Multi-Range Shunts

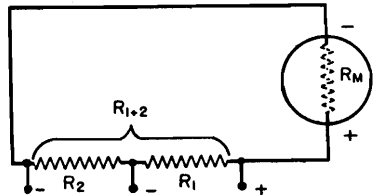

$$R_1 = \frac{R_{1+2} + R_m}{N}$$

R_1 = intermediate or tapped shunt value in ohms,

R_{1+2} = total resistance required for the lowest scale reading wanted,

R_m = meter resistance in ohms,

N = the new full scale reading divided by the original full scale reading, both being stated in the same units.

Voltage Multipliers

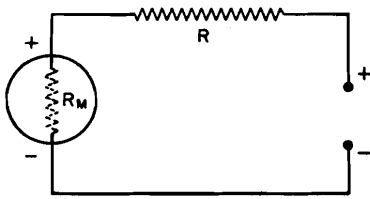

$$R = \frac{E_{fs}}{I_{fs}} - R_m$$

R = multiplier resistance in ohms,
E_{fs} = full scale reading required in volts,
I_{fs} = full scale current of meter in amperes,
R_m = meter resistance in ohms.

Measuring Resistance

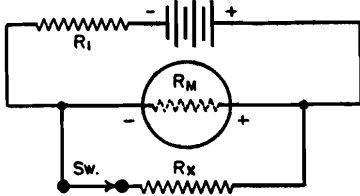

with Milliammeter and Battery*

$$R_x = R_m \left(\frac{I_2}{I_1 - I_2} \right)$$

R_x = unknown resistance in ohms,
R_m = meter resistance in ohms, or effective meter resistance if a shunted range is used,
I₁ = current reading with switch open,
I₂ = current reading with switch closed,
R₁ = current limiting resistor of sufficient value to keep meter reading on scale when switch is open.

* Approximately true only when current limiting resistor is large as compared to meter resistance.

Shunt Values for 27-Ohm 0-1 Milliammeter

FULL SCALE CURRENT	SHUNT RESISTANCE
0-10 ma	3.0 ohms
0-50 ma	0.551 ohms
0-100 ma	0.272 ohms
0-500 ma	0.0541 ohms

Measuring Resistance—(Continued)

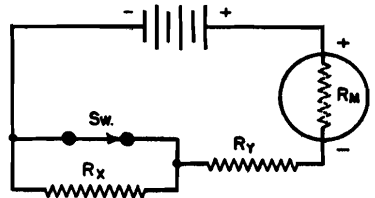

with Milliammeter, Battery and Known Resistor

$$R_x = (R_y + R_m) \left(\frac{I_1 - I_2}{I_2} \right)$$

R_x = unknown resistance in ohms,
R_y = known resistance in ohms,
R_m = meter resistance in ohms,
I₁ = current reading with switch closed,
I₂ = current reading with switch open.

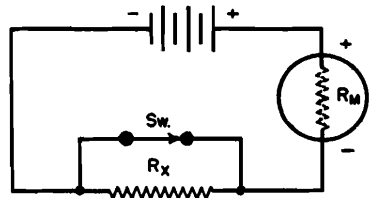

with Voltmeter and Battery

$$R_x = R_m \left(\frac{E_1}{E_2} - 1 \right)$$

R_x = unknown resistance in ohms,
R_m = meter resistance in ohms, including multiplier resistance if a multiplied range is used,
E₁ = voltmeter reading with switch closed,
E₂ = voltmeter reading with switch open.

Multiplier Values for 27-Ohm 0-1 Milliammeter

FULL SCALE VOLTAGE	MULTIPLIER RESISTANCE
0-10 volts	10,000 ohms
0-50 volts	50,000 ohms
0-100 volts	100,000 ohms
0-250 volts	250,000 ohms
0-500 volts	500,000 ohms
0-1,000 volts	1,000,000 ohms

Ohm's Law for A-C Circuits

The fundamental Ohm's law formulas for a-c circuits are given by

$$I = \frac{E}{Z}, \quad Z = \frac{E}{I},$$

$$E = IZ, \quad P = EI \cos \theta$$

where I = current in amperes,
 Z = impedance in Ohms,
 E = volts across Z ,
 P = power in watts,
 θ = phase angle in degrees.

Phase Angle

The phase angle is defined as the difference in degrees by which current leads voltage in a capacitive circuit, or lags voltage in an inductive circuit, and in series circuits is equal to the angle whose tangent is given by the

ratio $\frac{X}{R}$ and is expressed by

$$\text{arc tan } \frac{X}{R}$$

where X = the inductive or capacitive reactance in ohms,

R = the non-reactive resistance in ohms,

of the combined resistive and reactive components of the circuit under consideration.

Therefore

in a purely resistive circuit, $\theta = 0^\circ$

in a purely reactive circuit, $\theta = 90^\circ$

and in a resonant circuit, $\theta = 0^\circ$

also when

$\theta = 0^\circ$, $\cos \theta = 1$ and $P = EI$,

$\theta = 90^\circ$, $\cos \theta = 0$ and $P = 0$.

Degrees $\times 0.0175$ = radians.

1 radian = 57.3° .

Power Factor

The power-factor of any a-c circuit is equal to the true power in watts divided by the apparent power in volt-amperes which is equal to the cosine of the phase angle, and is expressed by

$$p.f. = \frac{EI \cos \theta}{EI} = \cos \theta$$

where

$p.f.$ = the circuit load power factor,

$EI \cos \theta$ = the true power in watts,

EI = the apparent power in volt-amperes,

E = the applied potential in volts

I = load current in amperes.

Therefore

in a purely resistive circuit,

$$\theta = 0^\circ \text{ and } p.f. = 1$$

and in a reactive circuit,

$$\theta = 90^\circ \text{ and } p.f. = 0$$

and in a resonant circuit,

$$\theta = 0^\circ \text{ and } p.f. = 1$$

Ohm's Law for D-C Circuits

The fundamental Ohm's law formulas for d-c circuits are given by,

$$I = \frac{E}{R}, \quad R = \frac{E}{I},$$

$$E = IR, \quad P = EI.$$

where I = current in amperes,

R = resistance in ohms,

E = potential across R in volts,

P = power in watts.

Ohm's Law Formulas for D-C Circuits

Known Values	Formulas for Determining Unknown Values of . . .			
	<i>I</i>	<i>R</i>	<i>E</i>	<i>P</i>
<i>I</i> & <i>R</i>			IR	I^2R
<i>I</i> & <i>E</i>		$\frac{E}{I}$		EI
<i>I</i> & <i>P</i>		$\frac{P}{I^2}$	$\frac{P}{I}$	
<i>R</i> & <i>E</i>	$\frac{E}{R}$			$\frac{E^2}{R}$
<i>R</i> & <i>P</i>	$\sqrt{\frac{P}{R}}$		\sqrt{PR}	
<i>E</i> & <i>P</i>	$\frac{P}{E}$	$\frac{E^2}{P}$		

Ohm's Law Formulas for A-C Circuits

Known Values	Formulas for Determining Unknown Values of . . .			
	<i>I</i>	<i>Z</i>	<i>E</i>	<i>P</i>
<i>I</i> & <i>Z</i>			IZ	$I^2Z \cos \theta$
<i>I</i> & <i>E</i>		$\frac{E}{I}$		$IE \cos \theta$
<i>I</i> & <i>P</i>		$\frac{P}{I^2 \cos \theta}$	$\frac{P}{I \cos \theta}$	
<i>Z</i> & <i>E</i>	$\frac{E}{Z}$			$\frac{E^2 \cos \theta}{Z}$
<i>Z</i> & <i>P</i>	$\sqrt{\frac{P}{Z \cos \theta}}$		$\sqrt{\frac{PZ}{\cos \theta}}$	
<i>E</i> & <i>P</i>	$\frac{P}{E \cos \theta}$	$\frac{E^2 \cos \theta}{P}$		

Coil Winding Data

Turns Per Inch

Gauge (AWG) or (B&S)	Number of Turns per Linear Inch			
	Enamel	S.S.C.	D.S.C. and S.C.C.	D.C.C.
1	—	—	3.3	3.3
2	—	—	3.8	3.6
3	—	—	4.2	4.0
4	—	—	4.7	4.5
5	—	—	5.2	5.0
6	—	—	5.9	5.6
7	—	—	6.5	6.2
8	7.6	—	7.4	7.1
9	8.6	—	8.2	7.8
10	9.6	—	9.3	8.9
11	10.7	—	10.3	9.8
12	12.0	—	11.5	10.9
13	13.5	—	12.8	12.0
14	15.0	—	14.2	13.8
15	16.8	—	15.8	14.7
16	18.9	18.9	17.9	16.4
17	21.2	21.2	19.9	18.1
18	23.6	23.6	22.0	19.8
19	26.4	26.4	24.4	21.8
20	29.4	29.4	27.0	23.8
21	33.1	32.7	29.8	26.0
22	37.0	36.5	34.1	30.0
23	41.3	40.6	37.6	31.6
24	46.3	45.3	41.5	35.6
25	51.7	50.4	45.6	38.6
26	58.0	55.6	50.2	41.8
27	64.9	61.5	55.0	45.0
28	72.7	68.6	60.2	48.5
29	81.6	74.8	65.4	51.8
30	90.5	83.3	71.5	55.5
31	101.	92.0	77.5	59.2
32	113.	101.	83.6	62.6
33	127.	110.	90.3	66.3
34	143.	120.	97.0	70.0
35	158.	132.	104.	73.5
36	175.	143.	111.	77.0
37	198.	154.	118.	80.3
38	224.	166.	126.	83.6
39	248.	181.	133.	86.6
40	282.	194.	140.	89.7

Coil Winding Formulas

The following approximations for winding r - f coils are accurate to within approx. 1% for nearly all small air-core coils, where

- L = self inductance in microhenrys,
- N = total number of turns,
- r = mean radius in inches,
- l = length of coil in inches,
- b = depth of coil in inches.

Single-Layer Wound Coils

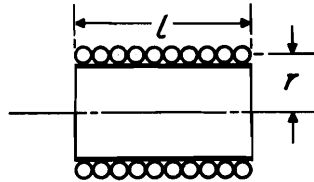

$$L = \frac{(rN)^2}{9r + 10l}$$

$$N = \frac{\sqrt{L(9r + 10l)}}{r}$$

Multi-Layer Wound Coils

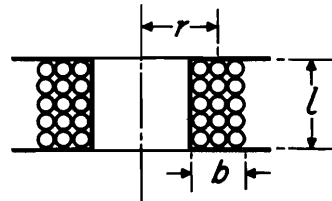

$$L = \frac{0.8(rN)^2}{6r + 9l + 10b}$$

Single-Layer Spiral Wound Coils

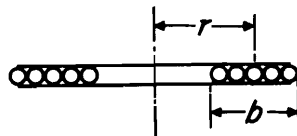

$$L = \frac{(rN)^2}{8r + 11b}$$

**Table of Standard Annealed Bare Copper Wire
Using American Wire Gauge (B & S)**

Gauge (AWG) or (B & S)	DIAMETER INCHES			AREA	WEIGHT	LENGTH	RESISTANCE AT 68° F			Current Capacity (Amps)- Rubber Insulated
	Min.	Nom.	Max.	Circular Mils	Pounds per M'	Feet per Lb.	Ohms per M'	Feet per Ohm	Ohms per Lb.	
0000	.4554	.4600	.4646	211600.	640.5	1.561	.04901	20400.	.00007652	225
000	.4055	.4096	.4137	167800.	507.9	1.968	.06180	16180.	.0001217	175
00	.3612	.3648	.3684	133100.	402.8	2.482	.07793	12830.	.0001935	150
0	.3217	.3249	.3281	105500.	319.5	3.130	.09827	10180.	.0003076	125
1	.2864	.2893	.2922	83690.	253.3	3.947	.1239	8070.	.0004891	100
2	.2550	.2576	.2602	66370.	200.9	4.977	.1563	6400.	.0007778	90
3	.2271	.2294	.2317	52640.	159.3	6.276	.1970	5075.	.001237	80
4	.2023	.2043	.2063	41740.	126.4	7.914	.2485	4025.	.001966	70
5	.1801	.1819	.1837	33100.	100.2	9.980	.3133	3192.	.003127	55
6	.1604	.1620	.1636	26250.	79.46	12.58	.3951	2531.	.004972	50
7	.1429	.1443	.1457	20820.	63.02	15.87	.4982	2007.	.007905	
8	.1272	.1285	.1298	16510.	49.98	20.01	.6282	1592.	.01257	35
9	.1133	.1144	.1155	13090.	39.63	25.23	.7921	1262.	.01999	
10	.1009	.1019	.1029	10380.	31.43	31.82	.9989	1001.	.03178	25
11	.08983	.09074	.09165	8234.	24.92	40.12	1.260	794.	.05053	
12	.08000	.08081	.08162	6530.	19.77	50.59	1.588	629.6	.08035	20
13	.07124	.07196	.07268	5178.	15.68	63.80	2.003	499.3	.1278	
14	.06344	.06408	.06472	4107.	12.43	80.44	2.525	396.0	.2032	15
15	.05650	.05707	.05764	3257.	9.858	101.4	3.184	314.0	.3230	
16	.05031	.05082	.05133	2583.	7.818	127.9	4.016	249.0	.5136	6
17	.04481	.04526	.04571	2048.	6.200	161.3	5.064	197.5	.8167	
18	.03990	.04030	.04070	1624.	4.917	203.4	6.385	156.5	1.299	3
19	.03553	.03589	.03625	1288.	3.899	256.5	8.051	124.2	2.065	
20	.03164	.03196	.03228	1022.	3.092	323.4	10.15	98.5	3.283	
21	.02818	.02846	.02874	810.1	2.452	407.8	12.80	78.11	5.221	
22	.02510	.02535	.02560	642.4	1.945	514.2	16.14	61.95	8.301	
23	.02234	.02257	.02280	509.5	1.542	648.4	20.36	49.13	13.20	
24	.01990	.02010	.02030	404.0	1.223	817.7	25.67	38.96	20.99	
25	.01770	.01790	.01810	320.4	.9699	1031.	32.37	30.90	33.37	
26	.01578	.01594	.01610	254.1	.7692	1300.	40.81	24.50	53.06	
27	.01406	.01420	.01434	201.5	.6100	1639.	51.47	19.43	84.37	
28	.01251	.01264	.01277	159.8	.4837	2067.	64.90	15.41	134.2	
29	.01115	.01126	.01137	126.7	.3836	2607.	81.83	12.22	213.3	
30	.00993	.01003	.01013	100.5	.3042	3287.	103.2	9.691	339.2	
31	.008828	.008928	.009028	79.7	.2413	4145.	130.1	7.685	539.3	
32	.007850	.007950	.008050	63.21	.1913	5227.	164.1	6.095	857.6	
33	.006980	.007080	.007180	50.13	.1517	6591.	206.9	4.833	1364.	
34	.006205	.006305	.006405	39.75	.1203	8310.	260.9	3.833	2168.	
35	.005515	.005615	.005715	31.52	.09542	10480.	329.0	3.040	3448.	
36	.004900	.005000	.005100	25.00	.07568	13210.	414.8	2.411	5482.	
37	.004353	.004453	.004553	19.83	.06001	16660.	523.1	1.912	8717.	
38	.003865	.003965	.004065	15.72	.04759	21010.	659.6	1.516	13860.	
39	.003431	.003531	.003631	12.47	.03774	26500.	831.8	1.202	22040.	
40	.003045	.003145	.003245	9.888	.02993	33410.	1049.	0.9534	35040.	
41	.00270	.00280	.00290	7.8400	.02373	42140.	1323.	.7559	55750.	
42	.00239	.00249	.00259	6.2001	.01877	53270.	1673.	.5977	89120.	
43	.00212	.00222	.00232	4.9284	.01492	67020.	2104.	.4753	141000.	
44	.00187	.00197	.00207	3.8809	.01175	85100.	2672.	.3743	227380.	
45	.00166	.00176	.00186	3.0976	.00938	106600.	3348.	.2987	356890.	
46	.00147	.00157	.00167	2.4649	.00746	134040.	4207.	.2377	563900.	

*Note: Values from National Electrical Code.

Single-Layer Wound Coil Chart

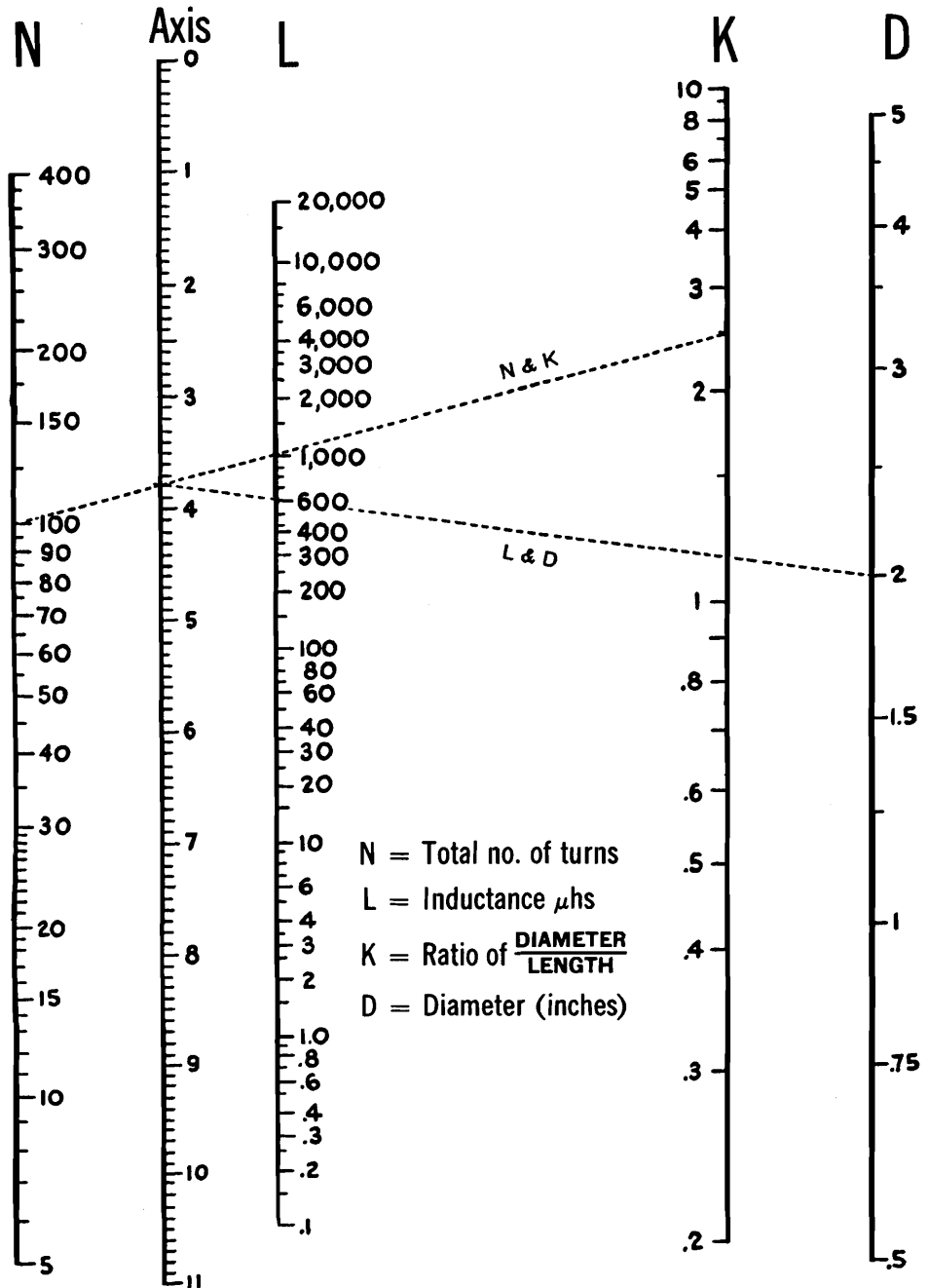

N = Total no. of turns
 L = Inductance μ hs
 K = Ratio of $\frac{\text{DIAMETER}}{\text{LENGTH}}$
 D = Diameter (inches)

Single-Layer Wound Coil Chart

The chart on the opposite page provides a convenient means of determining the unknown factors of small sized single-layer wound r-f coils. Values thus found so closely approximate those determined by measurement or mathematical calculation as to be entirely satisfactory for all practical purposes of experimentation, design, and repair work. Since in all coils of this type, the difference between the mean and inner diameter of the winding is so slight as to be negligible, D in all instances may be either the mean or inner diameter as desired.

Example: Given the total number of turns, winding length and diameter of a coil,— to find the inductance;

1. Place a straightedge on the chart so as to form a line intersecting the number of turns N , and the ratio of diameter to length K , and note the point intersected on the linear axis column.

2. Now move the straightedge so as to form a second line which will intersect this same point on the axis column, and the diameter D .
3. The point where this line intersects the L column indicates the inductance of the coil in microhenries.

Example: Given the diameter, winding length and inductance in microhenries,— to find the number of turns;

1. Simply reverse the process outlined above for determining inductance.
2. After finding the number of turns, consult the wire table on page 26 and determine the size of wire to be used.

The dotted lines appearing on the chart illustrate the correct plotting of a 600-microhenry coil consisting of 100 turns of wire, wound to $51/64''$ on a form $2''$ in diameter.

Inductance, Capacitance, Reactance Charts

The direct-reading charts appearing on the following three pages are designed for determining unknown values of frequency, inductance, capacitance and reactance components operating in a-f and r-f circuits.

The simplifications embodied in these charts make them extremely useful. The frequency range covered comprises the frequency spectrum from 1 cycle per second up to 1000 megacycles per second. All of the scales involved are plotted in actual magnitudes so that no computations are required to determine the location of the decimal point in the final result.

To make these conditions possible the frequency spectrum has been divided into three parts:

Chart I (page 30)—Covers the range from 1 cycle to 1000 cycles.

Chart II (page 31)—From 1 kilocycle to 1000 kilocycles.

Chart III (page 32)—From 1 megacycle to 1000 megacycles.

Inductance, capacitance, reactance and frequency have been plotted so that the reactance offered by an inductance or capacitance at any frequency may be readily determined by placing a straight-edge across the chart connecting the known quantities.

Since $X_L = X_C$ at resonance in most radio circuits, the charts may also be used to find the resonant frequency of any combination of L and C .

To illustrate with a simple example, suppose the reactance of a $0.01 \mu\text{f}$. capacitor is desired at a frequency of 400 cycles. Place a straight-edge across the proper chart so as to connect the points $0.01 \mu\text{f}$. and 400 cycles per sec. The quantity desired is the point of intersection with the reactance scale which is 40,000 ohms. The straight-edge also intersects the inductance scale at 15.8 henrys indicating that this value of inductance likewise has a reactance of 40,000 ohms at 400 cycles per sec. and furthermore, that these values of L and C produce resonance at this frequency.

There are many practical uses for these charts. The radio experimenter, maintenance man and engineer will find them helpful in the rapid solution of many reactance problems. Unusual care was exercised in laying out the various scales in order to secure a high degree of accuracy for the charts. Results should be obtainable which are at least as accurate as might be secured with a ten-inch slide rule.

Inductance, Capacitance, Reactance—(Continued)

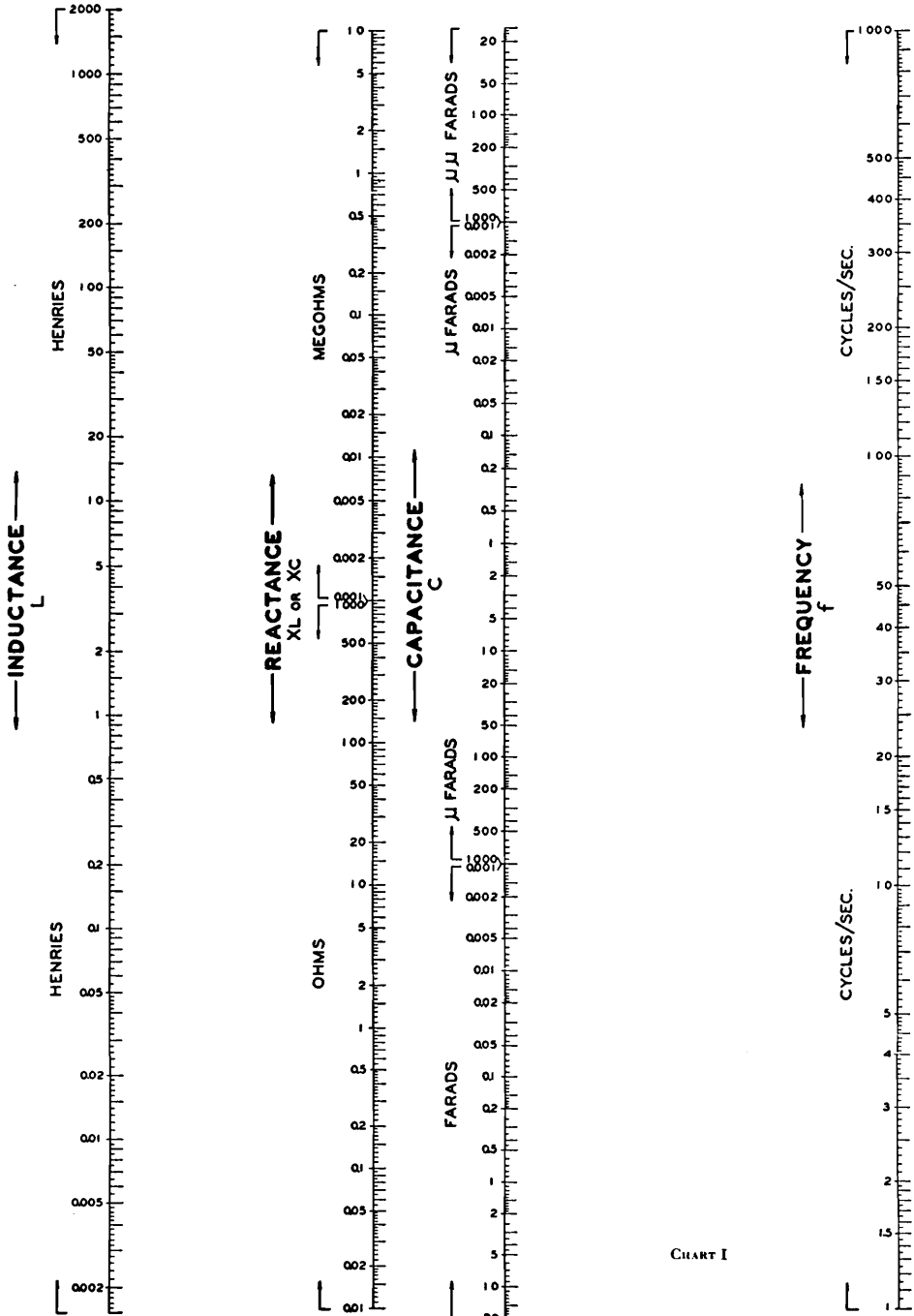

CHART I

Courtesy, Sylvania Electric Products Inc.

Inductance, Capacitance, Reactance—(Continued)

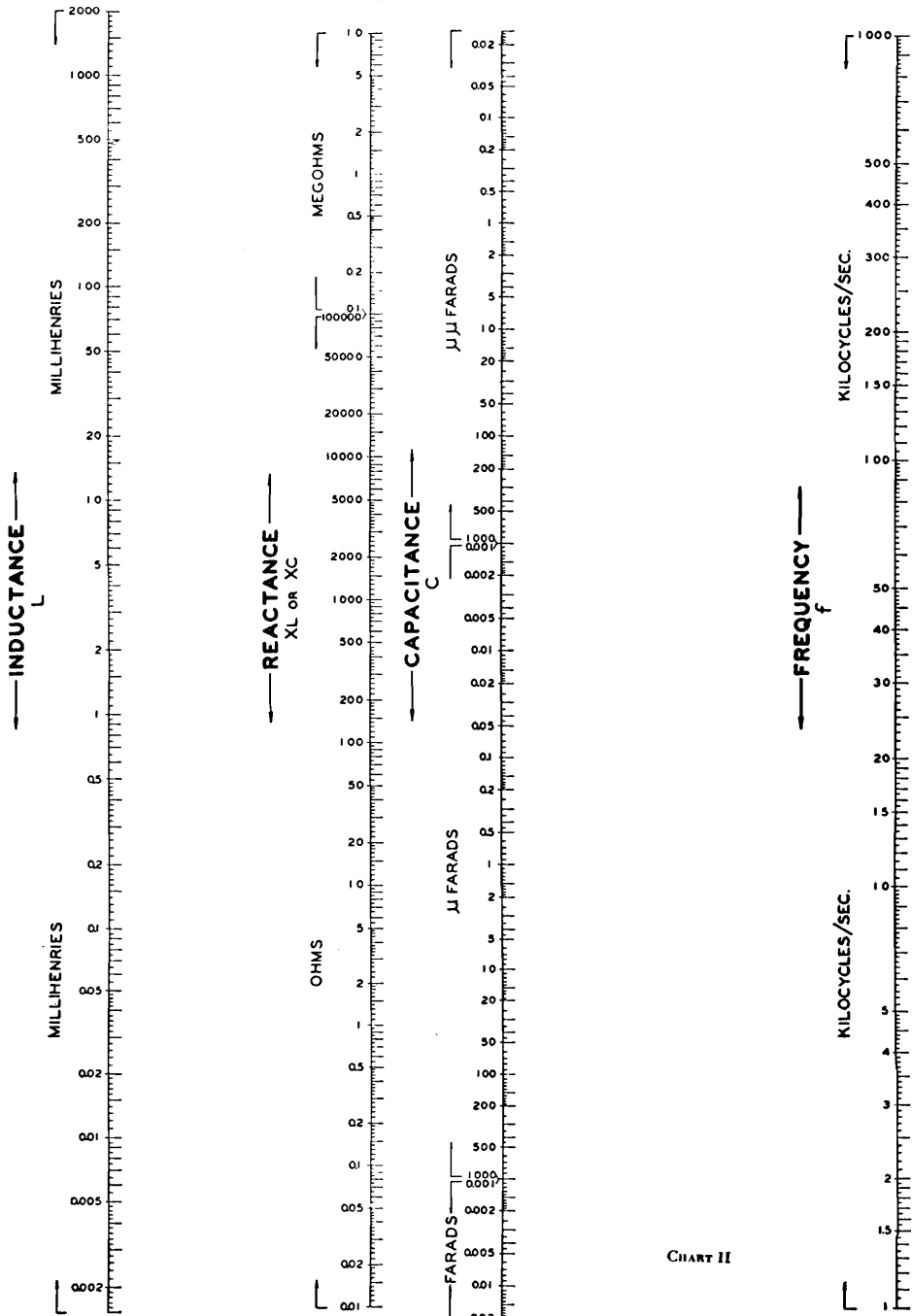

CHART II

Courtesy, Sylvania Electric Products Inc.

Inductance, Capacitance, Reactance—(Continued)

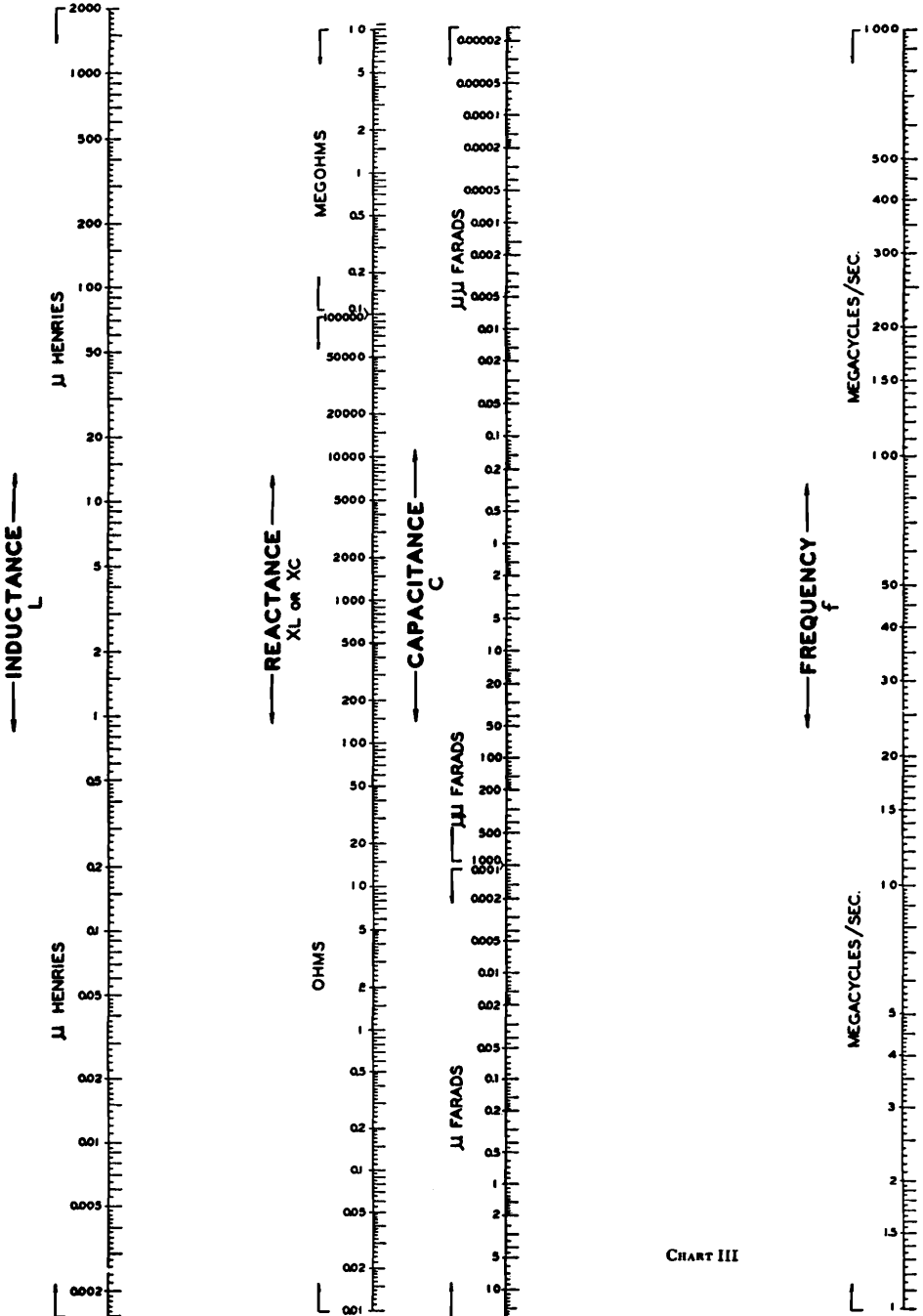
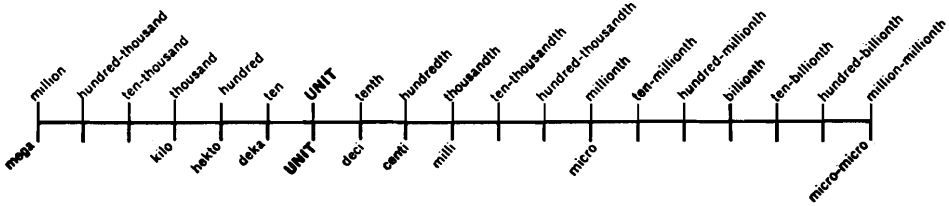

CHART III

Courtesy, Sylvania Electric Products Inc.

Metric Relationships



The above chart shows the relation between the American and the metric systems of notation.

This chart also serves to quickly locate the decimal point in the conversion from one metric expression to another.

Example: Convert 5.0 milliwatts to watts. Place the finger on milli and count the number of steps from there to units (since the

term watt is a basic unit). The number of steps so counted is three, and the direction was to the left. Therefore, 5.0 milliwatts is the equivalent of .005 watts.

Example: Convert 0.00035 microfarads to micromicrofarads. Here the number of steps counted will be six to the right. Therefore 0.00035 microfarads is the equivalent of 350 micromicrofarads.

Metric Conversion Table

ORIGINAL VALUE	DESIRED VALUE							
	Mega	Kilo	Units	Deci	Centi	Milli	Micro	Micromicro
Mega		3→	6→	7→	8→	9→	12→	18→
Kilo	← 3		3→	4→	5→	6→	9→	15→
Units	← 6	← 3		1→	2→	3→	6→	12→
Deci	← 7	← 4	← 1		1→	2→	5→	11→
Centi	← 8	← 5	← 2	← 1		1→	4→	10→
Milli	← 9	← 6	← 3	← 2	← 1		3→	9→
Micro	←12	← 9	← 6	← 5	← 4	← 3		6→
Micromicro	←18	←15	←12	←11	←10	← 9	← 6	

The above metric conversion table provides a fast and automatic means of conversion from one metric notation to another. The notation "Unit" represents the basic units of measurement, such as amperes, volts, ohms, watts, cycles, meters, grams, etc. To use the table, first locate the original or given value in the left-hand column. Now follow this line horizontally to the vertical column headed by the prefix of the desired value. The figure and arrow at this point indicates number of places and direction decimal point is to be moved.

Example: Convert 0.15 ampere to milliamperes. Starting at the "Units" box in the left-hand column (since ampere is a basic unit of measurement), move horizontally to the column headed by the prefix "Milli", and read 3→. Thus 0.15 ampere is the equivalent of 150 milliamperes.

Example: Convert 50,000 kilocycles to megacycles. Read in the box horizontal to "Kilo" and under "Mega", the notation ←3, which means a shift of the decimal three places to the left. Thus 50,000 kilocycles is the equivalent of 50 megacycles.

How to Use Logarithms

Logarithms are used to simplify numerical computations involving multiplications, division, powers and roots. With logarithms, multiplication is reduced to simple addition, and division is reduced to simple subtraction. Raising to a power is reduced to a single multiplication, and extracting a root is reduced to a single division.

The common logarithm of any number is the power to which 10 must be raised in order to equal that number.

Therefore, since

$$\begin{aligned} 1000 &= 10^3 \\ 100 &= 10^2 \\ 10 &= 10^1 \\ 1 &= 10^0 \\ 0.1 &= 10^{-1} \\ 0.01 &= 10^{-2} \\ 0.001 &= 10^{-3} \\ 0.0001 &= 10^{-4} \end{aligned}$$

it is true that

$$\begin{aligned} \log 1000 &= 3 \\ \log 100 &= 2 \\ \log 10 &= 1 \\ \log 1 &= 0 \\ \log 0.1 &= -1 \\ \log 0.01 &= -2 \\ \log 0.001 &= -3 \\ \log 0.0001 &= -4 \end{aligned}$$

The common system of logarithms has for its base the number 10, and is written \log_{10} or more commonly \log , since the base 10 is always implied unless some other base is specifically indicated. There are formulas however which use the natural system of logarithms. This system has for its base the number 2.718 . . . which is represented by the Greek letter ϵ and is always written $\log \epsilon$.

A table of natural logarithms has not been included in this handbook however, since the common log of a number is approximately equal to 0.4343 times the natural log of the same number. Conversely, the natural log of a number is approximately equal to 2.3026 times the common log of the same number.

In observing the following exponential and logarithmic relationships,

Exponential Form		Logarithmic Form	
100	$= 10^2$	$\log 100$	$= 2.000$
15	$= 10^{1.176}$	$\log 15$	$= 1.176$
10	$= 10^1$	$\log 10$	$= 1.000$
7	$= 10^{.845}$	$\log 7$	$= 0.845$
1	$= 10^0$	$\log 1$	$= 0.000$
0.1	$= 10^{-1}$	$\log 0.1$	$= -1.000$
0.7	$= 10^{-.1845}$	$\log 0.7$	$= -1.845$
0.015	$= 10^{-2.176}$	$\log 0.015$	$= -2.176$
0.001	$= 10^{-3}$	$\log 0.001$	$= -3.000$

it will be seen that only the direct powers of 10 have whole numbers for logarithms; also that the logarithms of all numbers lying between a power of 10, consist of a whole number and a decimal. The whole number is called the characteristic, and the decimal, the mantissa. Since the characteristic serves only to fix the location of the decimal point in the expression indicated by the log, it can be found by inspection and is not included in the log table. The following will be helpful:

1. The characteristic of any number greater than 1 is always positive and is equal to one less than the number of digits to the left of the decimal.
2. The characteristic of any number less than 1 is always negative and is equal to one plus the number of zeros to the decimal.
3. The characteristic of any number may be determined by expressing the number as a power of 10 and using this power as the characteristic of the logarithm for that number.

Since only the characteristic of a logarithm is ever negative, the mantissa always being a positive number, it is customary to write a log containing a negative characteristic as follows:

$$\log 0.7 = \bar{1}.845,$$

or, by adding +10 to the characteristic and, in order to maintain equality, -10 at the right of the characteristic,

$$\log 0.7 = 9.845 - 10$$

Examples:

150	1.5×10^2	2
15	1.5×10^1	1
1.5	1.5×10^0	0
0.15	1.5×10^{-1}	-1 or 9 - 10
0.015	1.5×10^{-2}	-2 or 8 - 10
0.0015	1.5×10^{-3}	-3 or 7 - 10

Therefore, to find the logarithm of any number:

1. Write the number as a power of 10, and put down the resulting exponent of 10 as the characteristic.
2. Determine the mantissa from the log tables on page 56, and write this as a decimal figure following the characteristic.
3. If the resulting logarithm has a negative characteristic, change this to the positive form.

Example: Find the logarithm of .00623:

Since $.00623 = 6.23 \times 10^{-3}$, the characteristic is -3. The mantissa as shown by the log table is 7945. The resultant logarithm = 3.7945 or when written in its positive form, 7.7945 - 10.

To find the log of any number having more than three significant figures (by interpolation):

1. Determine the characteristic.
2. Find the mantissa corresponding to the first three significant figures.
3. Find the next higher mantissa and take the tabular difference.
4. Find the product of the tabular difference and the digit following the first three significant figures of the given number written as a decimal.
5. Add this product to the lesser mantissa.

Example: Find the logarithm of 54.65.

Since $54.65 = 5.465 \times 10^1$, the characteristic is 1.

Next higher mantissa = .7380

Next lower mantissa = .7372

Tabular difference = .0008

× .5

Product .00040

Plus lesser mantissa .7372

Mantissa of 5.465 .7376

∴ log 54.65 = 1.7376

Although a four-place log table is used here, for purposes where accuracy to 3 significant figures is required, generally, a three place table is sufficiently accurate for all practical purposes. Since the mantissa of a logarithm represents only the significant figures of any number, the same mantissa is used for .04, 4, 400, etc., the decimal point being fixed later by the characteristic. Therefore any number consisting of 1 or 2 significant figures may be found in the column marked **N**, and its mantissa will be found on the same line in this column headed by **0**. For any number containing 3 significant figures, locate the first two figures in the **N** column, and the third figure in the column headed by the corresponding digit. The mantissa will be found in this column, on a line even with the first two digits.

Example:

log 21 = 1.3222

log 2.1 = 0.3222

log 210 = 2.3222

log .0021 = 7.3222 - 10

log 213 = 2.3284

log .0213 = 8.3284 - 10

log 3 = 0.4771

log 300 = 2.4771

log .003 = 7.4771 - 10

The number corresponding to a given logarithm is called the **antilogarithm**, and is written "antilog". Example: Since log of 692 = 2.8401, the antilog of 2.8401 = 692.

Finding the antilog of a number is the reverse of finding the logarithm. First locate the mantissa in the log table, and determine its corresponding number. Now, place the decimal as indicated by the characteristic.

Example: To find the antilog of 3.9138, look up 9138 in the log table. Its corresponding number is 82, or expressed as a power of 10, equals 8.2×10^1 . A characteristic of 3 means that 8.2 must be multiplied by 10^3 . Therefore, antilog 3.9138 = $8.2 \times 10^3 = 8200$.

Similarly

Antilog 5.9138 = $8.2 \times 10^5 = 82,0000$

Antilog 0.9138 = $8.2 \times 10^0 = 8.2$

Antilog 7.9138 - 10 = $8.2 \times 10^{-3} = 0.0082$

Antilog 9.9138 - 10 = $8.2 \times 10^{-1} = 0.82$

To find the antilogarithm of a logarithm

whose mantissa is not exactly given in the table,

1. Find the tabular difference between the next highest and next lowest mantissas.
2. Divide this by the difference between the given mantissa and the next lowest mantissa.
3. Add the resulting quotient to the significant figures expressed by the next lower mantissa.
4. Place the decimal as indicated by the given characteristic.

Example: Find the antilog of 1.7376

Next higher mantissa .7380
 Next lower mantissa .7372
 Tabular difference .0008

Given mantissa .7376
 Next lower mantissa .7372
 Tabular difference .0004

$$\text{Quotient of } \frac{.0004}{.0008} = .5$$

The resultant figure therefore is .5 larger than the significant figures expressed by the lesser mantissa .7372 or 546. The sequence of figures therefore is 546.5

$$\therefore \text{the antilog of } 1.7376 = 54.65$$

NOTE: When interpolating as shown above, do not exceed four significant figures in your answer since interpolated results from a four-place table are not accurate beyond this point.

Logarithms are added or subtracted like arithmetical numbers, provided they are written with positive characteristics. If the characteristic in the total is greater than 9, and the notation -10, -20, -30, etc., appears after the mantissa, subtract a multiple of 10 from the positive part and add the same multiple of 10 to the negative part, so as to make the resultant characteristic less than 10.

EXAMPLES:

Addition of logarithms

2.764	6.326 - 10	6.328 - 10
4.304	6.284	7.764 - 10
7.068	12.610 - 10	9.104 - 10
	or	23.196 - 30
	2.610	or
		3.196 - 10

Subtraction of logarithms

$$\begin{array}{r} 4.107 \left\{ \begin{array}{l} = 14.107 - 10 \\ = 6.986 \end{array} \right. \\ \underline{6.986} \\ 7.121 - 10 \\ \underline{11.672 - 10} \\ 5.785 - 10 \\ \underline{5.887} \end{array}$$

The relationships of logarithmic operations are expressed by the following formulas:

$$\log(a \times b) = \log a + \log b$$

$$\log\left(\frac{a}{b}\right) = \log a - \log b$$

$$\log(a)^b = b \log a$$

$$\log \sqrt[b]{a} = \frac{\log a}{b}$$

EXAMPLES

To Multiply 1.24 by 246

$$\log \text{ of } 1.24 = 0.0934$$

$$\log \text{ of } 246 = 2.3909$$

$$\text{Total } 2.4843$$

The antilog of 2.4843 = 305, which is as accurate as can be determined with a four-place table. The full answer to this problem is 305.04.

To Divide 961 by 224

$$\log \text{ of } 961 = 2.9827$$

$$\log \text{ of } 224 = 2.3502$$

$$\text{Difference } 0.6325$$

The antilog of 0.6325 = 4.29 which is as accurate as can be determined with a four-place table. The product of 224 and 4.29 is 960.96.

Powers: Find 12^2 by logarithms:

$$\log \text{ of } 12 = 1.0792$$

$$\times 2$$

$$2.1584$$

The antilog of 2.1584 = 144.

Roots

$$\text{Find } \sqrt[3]{343}$$

$$\log \text{ of } 343 = 2.5353 \div 3 = .8451$$

$$\text{The antilog of } .8451 = 7.$$

Logarithms of Negative Numbers. Because the logarithms of negative numbers are imaginary in character, they cannot be used in computation as with positive numbers. However, since the numerical results of multiplying, dividing, etc., are not affected by the signs, you can determine the numerical results by logarithms and later affix the final + or - signs by inspection.

Directly Interchangeable Tubes

Tube Number	Replace with	Tube Number	Replace with	Tube Number	Replace with
01A	40				
0A2	0B2				
0A3	VR75				
0A4	1267				
0B3	VR90				
0C3	VR105				
0D3	VR150				
0Y4	OY4G				
	{ CK1005				
0Z4	{ 1003				
	{ 0Z4A				
	{ 1B4				
	{ 32				
1A4	{ 34				
	{ 1A4P				
	{ 1A4T				
1A5	1G4				
1A7	1D7				
1AC5	1V5				
1AD5	1W5				
1AM4	1T4SF				
1AQ5	1R5SF				
1AS5	1U5SF				
	{ 1AU3				
	{ 1G3GT				
1B3GT	{ 1G3GT/1B3GT				
	{ 1J3GT				
	{ 1K3GT				
	{ 1N2				
	{ 1N2A				
	{ 1A4				
1B4	{ 32				
	{ 34				
1B8	1D8				
1C5	1Q5				
1C8	1E8				
1D5	1E5				
1D8	1B8				
1E4	1G4				
1E5	1D5				
1E8	1C8				
		1G3GT	{ 1AU3	1N2	{ 1N2A
			{ 1B3GT		{ 1AU3
			{ 1G3GT/1B3GT		
			{ 1J3GT	1N2A	{ 1N2
			{ 1K3GT		{ 1AU3
			{ 1N2		
			{ 1N2A	1N5	{ 1P5
		1G4	{ 1E4		{ 1D5
			{ 1H4	1P5	{ 1N5
		1G5	1J5		{ 1D5
				1Q5	1C5
		1H4	{ 1G4	1R5SF	1AQ5
			{ 1E4		
				1S6	1T6
		1J3GT	{ 1AU3		
			{ 1B3GT	1T4	{ 1L4
			{ 1G3GT/1B3GT		{ 1U4
			{ 1K3GT	1T4SF	1AM4
			{ 1N2		
			{ 1N2A	1T5	{ 1A5
		1J5	1G5		{ 1G4
				1T6	1S6
			{ 1AU3		
			{ 1B3GT	1U4	{ 1L4
			{ 1G3GT		{ 1T4
			{ 1G3GT/1B3GT	1U5	1DN5
			{ 1J3GT	1U5SF	1AS5
			{ 1N2	1V	6Z3
			{ 1N2A		
		1L4	{ 1T4	1V5	{ 1AC5
			{ 1U4		{ 1W5
		1LA4	1LB4	1W5	1V5
		1LA6	1LC6		
		1LB4	1LA4	1X2	{ 1X2A
					{ 1X2B
		1LC5	{ 1LG5		
			{ 1LN5	2A3	45
				2A7	2A7S
		1LC6	1LA6	2B7S	2B7
		1LG5	1LC5		
		1LN5	1LC5	2C52	{ 12SN7
		1M3	1N3		{ 12SX7

Directly Interchangeable Tubes—(Continued)

Tube Number	Replace with	Tube Number	Replace with	Tube Number	Replace with
2CY5	{ 2EA5 2EV5	3CF6	{ 3BZ6 3CB6 3DK6	4BZ7	{ 4BC8 4BQ7A 4BS8 4BZ8
2EA5	{ 2CY5 2EV5	3CS6	3BE6	4BZ8	{ 4BC8 4BQ7A 4BS8 4BZ7
2E5	2G5	3CY5	{ 3EA5 3EV5	4CB6	{ 4BZ6 4DE6 4DK6
2E30	5812	3DK6	{ 3BZ6 3CB6 3CF6	4DE6	{ 4BZ6 4CB6 4DK6
2E31	2E32	3EA5	{ 3CY5 3EV5	4DK6	{ 4BZ6 4CB6 4DK6
2E32	2E31	3LE4	3LF4	4GS8	4BU8
2E35	2E36	3Q4	3S4	5AT8	5CG8
2E36	2E35	3Q5	{ 3B5 3C5	5AX4	{ 5A24 5U4 5V4 5W4 5Y3 5Z4
2E41	2E42	3S4	3Q4	5AZ4	{ 5AX4 5U4 5V4 5W4 5Y3 5Z4
2E42	2E41	3S4SF	3W4	5BQ7A	{ 5BS8 5BZ7
2G5	2E5	3W4	3S4SF	5BS8	{ 4BC8 4BQ7A 4BZ7 4BZ8
2G21	2G22	4AU6	4BA6	4BU8	4GS8
2G22	2G21	4BA6	4AU6	4BZ6	{ 4CB6 4DE6 4DK6
3AU6	3BA6	4BA6	4AU6	5CG8	5AT8
3B5	{ 3C5 3Q5	4BC8	{ 4BQ7A 4BS8 4BZ7 4BZ8	5EA8	5U8
3B7	1291	4BQ7A	{ 4BC8 4BS8 4BZ7 4BZ8		
3BA6	3AU6	4BS8	{ 4BC8 4BQ7A 4BZ7 4BZ8		
3BC5	3CE5	4BU8	4GS8		
3BE6	3CS6	4BZ6	{ 4CB6 4DE6 4DK6		
3BU8	3GS8				
3BZ6	{ 3CB6 3CF6 3DK6				
3C5	{ 3B5 3Q5				
3CB6	{ 3BZ6 3CF6 3DK6				
3CE5	3BC5				
3CF6	{ 3BZ6 3CB6 3DK6				
3CS6	3BE6				

Directly Interchangeable Tubes—(Continued)

Tube Number	Replace with	Tube Number	Replace with	Tube Number	Replace with		
5T4	{ 5AX4 5AZ4 5U4 5V4 5W4 5Y3 5Z4	5Z4	{ 5AX4 5AZ4 5T4 5U4 5V4 5W4 5Y3	6AK7	6AG7		
				6AL5	5726		
				6AM8	6HJ8		
				6AT6	{ 6AV6 6BF6 6BK6 6BT6 6BU6		
						6AU4GT	{ 6AU4GTA 6CQ4 6DA4A 6DE4
6AU8A	{ 6AU8 6AW8A 6BA8A 6BH8						
		6AV5	{ 6AU5 6BD5				
				6AV6	6AT6		
5U4	{ 5AX4 5AZ4 5T4 5V4 5W4 5Z4	6A4	52	6AW8	{ 6AU8A 6BA8A		
		6A8	6J8				
		6AB7	{ 6AC7 6AJ7	6AW8A	6AU8A		
						6AC5G	6AC5GT
		5U8	5EA8	6AD4	6K4	6AX4	{ 6U4 6W4
5V4	{ 5AX4 5AZ4 5T4 5U4 5W4	6AD5	{ 6AE5 6AF5 6C5 6J5				
				6AD6	6AF6	6AX4GTA	{ 6AX4GTB 6DA4
		6AE5	{ 6AD5 6AF5 6C5 6J5				
				6AD5	{ 6C5 6D5 6AD5 6AE5	6B6	6Q7
6AF5	{ 6C5 6D5 6AD5 6AE5						
		6AF6	6AD6	6AG5	{ 6BC5 6BA6 6BD6 6CB6 6AU6	6BA6	{ 6AU6 6BD6 6AG5 6BC5 6CB6
5Y3	{ 5AX4 5AZ4 5T4 5U4 5V4 5W4 5Z4						
		5X3	{ 5Z3 80 83				
				5X4	5Y4		
						5Y4	5X4
5Z3	{ 5X3 80 83	6AJ7	{ 6AB7 6AC7				
				6AK5	6AJ5		

Directly Interchangeable Tubes—(Continued)

Tube Number	Replace with	Tube Number	Replace with	Tube Number	Replace with				
6BA8	{ 6AU8 6AW8A 6BH8	6BT6	6BK6	6CS6	6BE6				
		6BU6	6BF6			6CU6	{ 6BQ6GTB 6BQ6GTB/6CU6 6DQ6 6DQ6A 6DQ6B 6FH6		
		6BU8	6GS8						
6BC5	{ 6AG5 6AU6 6CB6	6BZ6	{ 6CE6 6CF6 6DE6 6DK6	6CY5	{ 6EA5 6EV5				
						6BC8	{ 6BC8 6BQ7A 6BS8 6BZ8 6CH7	6D5	{ 6AD5 6AE5 6AF5 6C5
6BF6	6BU6			6D7	6E7				
		6BG7	6BF7			6BZ8	{ 6BC8 6BQ7A 6BS8 6BZ7 6CH7	6DE6	{ 6BZ6 6CB6 6CF6 6DK6
6BH6	6BJ6			6C4	9002				
		6BH8	{ 6AU8A 6BA8A			6C5	{ 6AD5 6AE5 6AF5 6D5	6DK6	{ 6BZ6 6CB6 6CF6 6DE6
6BJ6	6BH6			6C6	{ 6D6 77				
		6BK6	{ 6AT6 6AV6 6BF6 6BT6 6BU6			6CB6	{ 6BZ6 6CF6 6DE6 6DK6	6E5	{ 6T5 6U5
6CD6G	{ 6DN6 6EX6			6E7	6D7				
						6C6	{ 6D6 77	6EA5	{ 6EV5 6CY5
6CG8	6AT8			6EV5	{ 6EA5 6CY5				
		6BQ6GT	{ 6BQ6GTA 6BQ6GTB 6BQ6GTB/6CU6 6CU6 6DQ6A 6DQ6B 6FH6			6CF6	{ 6BZ6 6CB6 6DE6 6DK6	6F4	6L4
6C6	{ 6D6 77			6F7	6F7S				
		6CG8	6AT8			6G5	{ 6E5 6T5 6U5		
6CH7	{ 6BC8 6BQ7A 6BS8 6BZ7 6BZ8			6G5	{ 6E5 6T5 6U5				

Directly Interchangeable Tubes—(Continued)

Tube Number	Replace with	Tube Number	Replace with	Tube Number	Replace with
6GH8	{ 6EA8 6U8A }	6SE7	{ 6SD7 6SJ7 6SK7 5613 }	6U8A	{ 6EA8 6GH8 }
6GS8	6BU8	6SF7	6SV7	6V7	{ 6R7 6U4 }
6H5	6U5	6SH7	{ 6SG7 6SJ7 6SK7 }	6W4	{ 6AX4 6S7 }
6J7	{ 1233 6K7 6U7 }	6SJ7	{ 6SK7 5693 }	6W7	6S7
6J8	{ 6A8 6K8 }	6SL7	{ 6SU7 5691 5692 }	6X5GT	0Z4
6K4	6AD4	6SN7	{ 5692 5691 }	6X8	6X8A
6K7	{ 6J7 6U7 }	6SQ7	6SR7	6Z3	1V
6K8	{ 6AB 6J8 }	6SR7	6SQ7	6Z5	6Y5
6L4	6F4	6ST7	6SZ7	7A4	7B4
6L6	{ 1614 5881 }	6SU7	6SL7	7A7	{ 7H7 7L7 }
6L7	1612	6SV7	6SF7	7AB7	1204
6P5	{ 6AD5 6AE5 6AF5 6C5 6J5 }	6SZ7	6ST7	7AF7	7F7
6Q7	{ 6B6 6R7 }	6T5	{ 6E5 6U5 }	7AG7	7AH7
6R7	{ 6Q7 6V7 }	6T8	6AK8	7AH7	7AG7
6SA7	6SB7Y	6U4	{ 6W4 6AX5 }	7AJ7	7H7
6S7	6W7	6U5	{ 6E5 6T5 }	7AU7	6AU7
6SB7Y	6SA7	6U7	6K7	7B4	7A4
6SD7	{ 6SE7 6SJ7 6SK7 5693 }	6U8	{ 6AX8 6EA8 6GH8 6U8A }	7B6	7E6
			{ 1252 6678 7731 }	7B7	{ 7C7 7AH7 }
				7B8	{ 7J7 7S7 }
				7C7	7B7
				7E5	1201
				7E6	7B6
				7E7	7R7
				7F7	7AF7
				7G7	7V7
				7H7	{ 7AL7 7L7 }
				7I7	7B8
				7L7	{ 7A7 7H7 }
				7R7	7E7
				7S7	{ 7B8 7J7 }
				7T7	{ 7A7 7H7 7V7 }
				7V7	{ 7T7 7A7 7H7 }

Directly Interchangeable Tubes—(Continued)

Tube Number	Replace with	Tube Number	Replace with	Tube Number	Replace with
7Z4	7X6			12SR7	12SQ7
8AU8A	8AW8A			12SW7	12SR7
8AW8A	8AU8A	12BT6	{ 12AT6 12AV6 12BK6 12BU6	12SX7	12SN7
10	10Y			12SY7	12SA7
10Y	10				
12A	71A	12BU6	12BF6	12W6GT	{ 12EN6 12L6GT
12A8	12K8				
		12BY7	{ 12BV7 12DQ7	14A7	12B7
12AT6	{ 12AV6 12BK6			14AF7	14F7
12AT7	12AU7	12C5/12CU5	{ 12C5 12CU5 12R5	14B6	14E6
12AU6	{ 12BA6 12BD6	12CS6	12BE6	14B8	{ 14J7 14S7
12AU7	12AT7	12CU6	{ 12BQ6GT 12DQ6A	14C7	{ 12B7 1284
		12J7	12K7	14E6	14B6
12AV6	{ 12AT6 12BK6 12BT6 12BU6	12K7	12J7	14E7	14R7
		12K8	12A8	14F7	14AF7
12AV7	12AZ7	12L6GT	{ 12EN6 12W6GT		
12AX4GTA	12D4A			14H7	{ 12B7 14A7
12AX7	12AY7	12L8	1644		
12AY7	12AX7	12SA7	12SY7	14J7	{ 14B8 14S7
12AZ7	12AV7	12SC7	1634	14R7	14E7
12B7	14A7			14S7	{ 14J7 14B8
		12SG7	{ 12SH7 12SJ7 12SK7	14W7	{ 12B7 14A7
12BA6	{ 12AU6 12BD6			17AX4GT	17D4
12BD6	{ 12AU6 12BA6	12SH7	{ 12SG7 12SJ7 12SK7	19C8	19T8
12BE6	12CS6			19T8	19C8
12BF6	12BU6	12SJ7	{ 12SG7 12SH7 12SK7		
				25A6	{ 25B6 25C6 25L6 5824
12BK6	{ 12AT6 12AV6 12BT6 12BU6	12SK7	{ 12SG7 12SH7 12SJ7	25A7	32L7
		12SN7	12SX7		
12BQ6GT	{ 12BQ6GTB/12CU6 12CU6 12DQ6A	12SQ7	12SR7		

Directly Interchangeable Tubes—(Continued)

Tube Number	Replace with	Tube Number	Replace with	Tube Number	Replace with
25AX4GT	25D4	57	58	1612	6L7
25B5	43	76	37		
		77	6C6	1614	6L6
25BQ6GA	{ 25BQ6GTB/25CU6 25CU6 25DQ6A	78	6D6	1620	6J7
25CD6	25DN6	80	{ 83 5Z3	1634	12SC7
		81	50		
25CU6	{ 25BQ6T 25BQ6GTB/25CU6 25DQ6A	82	{ 2A3 45	1644	12L8
25DN6	25CD6	83	5Z3, 80	5517	CK1003
25L6GT	25W6GT	85	75		
25S	1B5	117L7	117M7		{ 5591
25W6GT	25L6GT	117N7	117P7	5590	{ 9001 9003
25Y5	25Z5	950	1F4		
26BK6	26C6	954	956	5591	5590
26C6	26BK6	955	5731		
27	56	956	954	5608-A	53
		CK1005	{ OY4 OZ4A		
32	{ 1A4 1B4	CK1013	5517	5654	{ 6AJ5 6AK5
32L7	25A7	1201	7E5		
		1203	7C4	5672	5678
34	{ 1A4 1B4	1204	7AB7	5678	5672
36	39	1206	768		
37	76	1221	6C6		
39	36	1223	6J7	5691	{ 6SN7 5692
40	01A	1229	1A4		
41	42	1230	30	5692	{ 5691 6SN7
42	6B5	1231	7V7		
45	2A3	1232	7G7	5693	6SJ7
50	10	1267	0A4		
50A6	50Z6	1273	7A7	5725	{ 6AJ5 6AK5
50C6	50L6	1274	6X5		
50Y7	50Z7	1275	{ 5X3 80 83	5731	9J5
50Z6	50AX6	1280	14H7		
50Z7	50Y7	1284	12B7	5824	{ 25A6 25B6 25C6 25L6
53	5608-A	1291	3B7		
55	2A6	1294	1R4		
56	27	1299	3D6	5915	6BE6

Directly Interchangeable Tubes

British to American Tubes

British Tube Number	Replace with American Tube	British Tube Number	Replace with American Tube	British Tube Number	Replace with American Tube
1C1	1R5	66KU	6BT4	DP61	6AK5
1C2	1AC6	67PT	6CK5	DY80	1X2A
1C3	1AB6	108C1	0B2	DY86	1S2
1D13	1A3	121VP	12AC5	DY87	1S2A
1F2	1L4	141DDT	14L7	EAA91	6AL5
1F3	1T4	141TH	14K7	EABC80	6AK8
1FD1	1AH5	150C2	0A2	EAF42	6CT7
1FD9	1S5	150C3	0D3	EB91	6AL5
1P1	3C4	171DDP	17C8	EBC41	6CV7
1P10	3S4	311SU	31A3	EBC90	6AT6
1P11	3V4	451PT	45A5	EBC91	6AV6
6D2	6AL5	B152	12AT7	EBF80	6N8
6F12	6AM6	B319	7AN7	EBF83	6DR8
6F16	6CJ5	B329	12AU7	EBF89	6DC8
6F19	6BY7	B339	12AX7	EC86	6CM4
6F26	6BY7	D152	6AL5	EC90	6C4
6F33	6AS6	DA90	1A3	EC91	6AQ4
6FD12	6DC8	DAC32	1H5GT	EC92	6AB4
6L12	6AQ8	DAF91	1S5	EC95	6ER5
6L13	12AX7	DD6	6AL5	EC97	6FY5
6L34	6AQ4	DF33	1N5GT	ECC81	12AT7
6LD3	6CV7	DF62	1AD4	ECC82	12AU7
6LD12	6AK8	DF91	1T4	ECC83	12AX7
7D10	6CH6	DF92	1L4	ECC85	6AQ8
8D3	6AM6	DF97	1AN5	ECC88	6DJ8
8D5	6BR7	DF904	1U4	ECC91	6J6
8D7	6BS7	DH142	14L7	ECC189	6ES8
9D6	6CQ6	DH149	7C6	ECF80	6BL8
10C14	19D8	DH150	6CV7	ECF82	6U8
10LD3	14L7	DH719	6AK8	ECF86	6HG8
10P18	45B5	DK32	1A7GT	ECH42	6CU7
19SU	19Y3	DK91	1R5	ECH81	6AJ8
19U3	19X3	DK92	1AC6	ECH83	6DS8
20D3	12AH8	DK96	1AB6	ECL80	6AB8
30C1	9A8	DL33	3Q5GT	ECL82	6BM8
30L1	7AN7	DL35	1C5GT	ECL84	6DX8
30P18	15CW5	DL91	1S4	EF41	6CJ5
62DDT	6CV7	DL92	3S4	EF80	6BX6
62TH	6CU7	DL94	3V4	EF85	6BY7
62VP	6CJ5	DL95	3Q4	EF86	6267
63TP	6AB8	DL96	3C4	EF89	6DA6
64SPT	6BX6	DM70	1M3	EF91	6AM6
65ME	6BR5	DM71	1N3	EF92	6CQ6

Directly Interchangeable Tubes—(Continued)

British to American Tubes

British Tube Number	Replace with American Tube	British Tube Number	Replace with American Tube	British Tube Number	Replace with American Tube
EF93	6BA6	HK90	12BE6	UCH42	14K7
EF94	6AU6	HL92	50C5	UCH81	19D8
EF95	6AK5	HY90	35W4	UCL82	50BM8
EF97	6ES6	LZ319	9A8	UF41	12AC5
EF98	6ET6	N142	45A5	UL41	45A5
EF183	6EH7	N144	6AM5	UL84	45B5
EF184	6EJ7	N150	6CK5	UU12	6CA4
EH90	6CS6	N152	21A6	UY41	31A3
EK90	6BE6	N153	15A6	UY85	38A3
EL34	6CA7	N154	16A5	VP6	6CQ6
EL36	6CM5	N309	15A6	VP12D	12C8
EL37	6L6	N329	16A5	W149	7B7
EL38	6CN6	N359	21A6	W719	6BY7
EL41	6CK5	N709	6BQ5	W727	6BA6
EL81	6CJ6	PABC80	9AK8	WD142	12S7
EL83	6CK6	PCC84	7AN7	WD150	6CT7
EL84	6BQ5	PCC85	9AQ8	WD709	6N8
EL85	6BN5	PCC88	7DJ8	X142	14K7
EL86	6CW5	PCF80	9A8	X148	7S7
EL90	6AQ5	PCF82	9U8	X719	6AJ8
EL91	6AM5	PCL82	16A8	X727	6BE6
EL95	6DL5	PL36	25E5	XC95	2ER5
EL821	6CH6	PL81	21A6	XCC189	4ES8
EM34	6CD7	PL82	16A5	XCF80	4BL8
EM80	6BR5	PL83	15A6	XF183	3EH7
EM81	6DA5	PY80	19X3	XF184	3EJ7
EM84	6FG6	PY81	17Z3	XL84	8BQ5
EQ80	6BE7	PY82	19Y3	YF88	16AQ3
EY81	6R3	PY83	17Z3	YF183	4EH7
EY86	6S2	QV05-25	807	XY184	4EJ7
EY88	6AL3	R16	1T2	Z152	6BX6
EZ35	6X5G	R19	1X2A	Z719	6BX6
EZ40	6BT4	R52	5Z4G	Z729	6267
EZ80	6V4	SP6	6AM6	ZD152	6N8
EZ81	6CA4	U70	6X5G		
EZ90	6X4	U147	6X5G		
GZ30	5AZ4	U149	7Y4		
GZ32	5V4G	U150	6BT4		
GZ34	5AR4	U192	19Y3		
HBC90	12AT6	U381	38A3		
HBC91	12AV6	UAF42	12S7		
HCC85	17EW8	UBC41	14L7		
HF93	12BA6	UBF80	17C8		

See Pages 50-51
for Listing of
American to British
Directly Interchangeable
Tubes.

Directly Interchangeable Tubes

American to British Tubes

American Tube Number	Replace with British Tube	American Tube Number	Replace with British Tube	American Tube Number	Replace with British Tube
0A2	150C2	3V4	{ 1P11 DL94	6BE6	{ EK90 X727
0B2	108C1	4BL8	XCF80	6BE7	EQ80
0D3	150C3	4EH7	YF183	6BL8	ECF80
1A3	{ 1D13 DA90	4EJ7	YF184	6BM8	ECL82
1A7GT	DK32	4ES8	XCC189	6BN5	EL85
1AB6	{ DK96 1C3	5AR4	GZ34	6BQ5	{ EL84 N709
1AC6	{ 1C2 DK92	5AZ4	GZ30	6BR5	{ 65ME EM80
1AD4	DF62	5V4G	GZ32	6BR7	8D5
1AH5	1FD1	5Z4G	R52	6BS7	8D7
1AN5	DF97	6AB4	EC92	6BT4	{ 66KU EZ40 U150
1C5GT	DL35	6AB8	{ 63TP ECL80	6BX6	{ 64SPT EF80 Z152 Z719
1H5GT	DAC32	6AJ8	{ ECH81 X719	6BY7	{ 6F19 6F26 EF85 W719
1L4	{ 1F2 DF92	6AK5	{ DP61 EF95	6C4	EC90
1M3	DM70	6AK8	{ 6LD12 DH719 EABC80	6CA4	{ EZ81 UU12
1N3	DM71	6AL3	EY88	6CA7	EL34
1N5GT	DF33	6AL5	{ 6D2 D152 DD6 EAA91 EB91	6CD7	EM34
1R5	{ 1C1 DK91	6AM5	{ EL91 N144	6CH6	{ 7D10 EL821
1S2	DY86	6AM6	{ 6F12 8D3 EF91 SP6	6CJ5	{ 6F16 62VP EF41
1S2A	DY87	6AQ4	{ 6L34 EC91	6CJ6	EL81
1S4	DL91	6AQ5	EL90	6CK5	{ 67PT EL41 N150
1S5	{ 1FD9 DAF91	6AQ8	{ 6L12 ECC85	6CK6	EL83
1T2	R16	6AS6	CF33	6CM4	EC86
1T4	{ 1F3 DF91	6AT6	EBC90	6CM5	EL36
1U4	DF904	6AU6	EF94	6CN6	EL38
1X2A	{ DY80 R19	6AV6	EBC91	6CQ6	{ 9D6 EF92 VP6
2ER5	XC95	6BA6	{ EF93 W727		
3C4	{ 1P1 DL96				
3EH7	XF183				
3EJ7	XF184				
3Q4	DL95				
3Q5GT	DL33				
3S4	{ 1P10 DL92				

Directly Interchangeable Tubes--(Continued)

American to British Tubes

American Tube Number	Replace with British Tube	American Tube Number	Replace with British Tube	American Tube Number	Replace with British Tube
6CS6	EH90	7B7	W149	16A8	PCL82
6CT7	{ EAF42 WD150	7C6	DH149	16AQ3	XY88
6CU7	{ 62TH ECH42	7DJ8	PCC88	17C8	{ 171DDP UBF80
6CV7	{ 6LD3 62DDT DH150 EBC41	7S7	X148	17EW8	HCC85
6CW5	EL86	7Y4	U149	17Z3	{ PY81 PY83
6DA5	EM81	8BQ5	XL84	19D8	{ 10C14 UCH81
6DA6	EF89	9A8	{ 30C1 LZ319 PCF80	19X3	{ 19U3 PY80
6DC8	{ 6FD12 EBF89	9AK8	PABC80	19Y3	{ 19SU PY82 UI92
6DJ8	ECC88	9AQ8	PCC85	21A6	{ N152 N359 PL81
6DL5	EL95	9U8	PCF82	25E5	PL36
6DR8	EBF83	12AC5	{ 121VP UF41	31A3	{ 311SU UY41
6DS8	ECH83	12AH8	20D3	35W4	HY90
6DX8	ECL84	12AT6	HBC90	38A3	{ U381 UY85
6EH7	EF183	12AT7	{ B152 ECC81	45A5	{ 451PT N142 UL41
6EJ7	EF184	12AU7	{ B329 ECC82	45B5	{ 10P18 UL84
6ER5	EC95	12AV6	HBC91	50BM8	UCL82
6ES6	EF97	12AX7	{ 6L13 B339 ECC83	50C5	HL92
6ES8	ECC189	12BA6	HF93	807	QV05-25
6ET6	EF98	12BE6	HK90	6267	{ EF86 Z729
6FG6	EM84	12C8	VP12D		
6FY5	EC97	12S7	{ UAF42 WD142		
6HG8	ECF86	14K7	{ 141TH UCH42 X142		
6J6	ECC91	14L7	{ 10LD3 141DDT DH142 UBC41		
6L6	EL37	15A6	{ N153 N309 PL83		
6N8	{ EBF80 WD709 ZD152	15CW5	30P18		
6R3	EY81	16A5	{ N154 N329 PL82		
6S2	EY86				
6U8	ECF82				
6V4	EZ80				
6X4	EZ90				
6X5G	{ EZ35 U70 U147				
7AN7	{ 30L1 B319 PCC84				

Directly Interchangeable TV Picture Tubes

Tube Number	Replace with	Tube Number	Replace with	Tube Number	Replace with
7NP4	7WP4*	12UP4	12UP4A	16GP4C	16GP4 16GP4A 16GP4B
7WP4	7NP4	12VP4	12VP4A	16HP4	16HP4A
8AP4	8AP4A	14AUP4	14AWP4	16HP4A	16HP4
8AP4A	8AP4	14AWP4	14AUP4	16JP4	16JP4A
10ABP4	10ABP4A 10ABP4B 10ABP4C	14BP4	14BP4A 14CP4	16JP4A	16JP4
10BP4	10BP4A 10FP4*	14BP4A	14EP4	16KP4	16KP4A 16RP4
10BP4A	10FP4A*	14CP4	14BP4 14BP4A 14EP4	16KP4A	16TP4
10EP4	10CP4	14EP4	14BP4 14BP4A 14CP4	16LP4	16LP4A 16ZP4
10FP4	10FP4A	14FP4	14BP4* 14BP4A* 14CP4* 14EP4*	16LP4A	16LP4 16ZP4
10MP4	10MP4A	15CP4	16CP4	16MP4	16MP4A
10MP4A	10MP4	16AP4	16AP4A	16MP4A	16MP4
12KP4	12KP4A	16AP4A	16AP4	16QP4	16XP4
12LP4	12LP4A	16AP4A	16AP4	16RP4	16KP4 16KP4A 16TP4
12LP4A	12KP4* 12KP4A* 12LP4 12LP4C	16CP4	15CP4	16RP4A	16RP4 16KP4 16KP4A
12QP4	12QP4A 12JP4*	16DP4	16DP4A	16SP4	16SP4A
12QP4A	12RP4	16DP4A	16HP4* 16HP4A* 16JP4* 16JP4A* 16MP4* 16MP4A*	16SP4A	16SP4
12RP4	12JP4* 12QP4 12QP4A	16EP4	16EP4A 16EP4B	16VP4	16YP4*
12TP4	12KP4** 12KP4A** 12RP4* 12VP4* 12VP4A*	16GP4	16GP4A 16GP4B	16WP4	16SP4* 16SP4A* 16WP4A*

*Connect external connector to chassis.

*Remove ion trap.

Directly Interchangeable TV Picture Tubes—(Continued)

Tube Number	Replace with	Tube Number	Replace with	Tube Number	Replace with
16WP4A	16SP4 16SP4A	17CBP4	17BUP4	19DP4	19DP4A
16XP4	16QP4	17CKP4	17BRP4 17BZP4 17CAP4	19DP4A	19DP4
16ZP4	16LP4 16LP4A	17CP4	17CP4A	19EP4	19JP4
17AP4	17BP4A 17BP4B 17BP4C 17JP4	17CP4A	17CP4	19FP4	19DP4* 19DP4A*
17ATP4	17ATP4A 17AVP4 17AVP4A	17DJP4	17DCP4*	19JP4	19EP4
17AVP4	17AVP4A 17ATP4 17ATP4A	17FP4	17FP4A	20CP4	20CP4A 20CP4C 20DP4 20DP4A*
17BP4	17AP4* 17BP4A* 17BP4B* 17BP4C* 17JP4*	17FP4A	17FP4	20CP4A	20CP4B 20CP4C 20DP4A
17BP4A	17BP4B 17BP4C 17JP4	17HP4	17HP4A 17HP4B	20CP4C	20CP4 20CP4A* 20DP4
17BP4B	17JP4	17HP4A	17HP4 17HP4B	20CP4C	20CP4 20CP4A* 20DP4
17BP4C	17JP4	17JP4	17AP4 17BP4A 17BP4B 17BP4C	20CP4C	20DP4A*
17BRP4	17BZP4 17CAP4 17CKP4	17LP4	17LP4A 17VP4	20DP4	20CP4 20CP4C 20CP4A* 20DP4A*
17BUP4	17CBP4	17LP4A	17VP4	20FP4	20GP4* 20JP4
17BZP4	17BRP4 17CAP4 17CKP4	17QP4	17UP4	20GP4	20JP4
17CAP4	17BRP4 17BZP4 17CKP4	17RP4	17HP4 17HP4A 17KP4	20HP4	20HP4A* 20HP4B 20LP4*
		17UP4	17QP4	20HP4B	20HP4A* 20LP4*
		17VP4	17LP4 17LP4A 17SP4	21ACP4	21ACP4A 21AMP4 21AMP4A
		19AFP4	19AUP4	21ALP4	21ALP4A 21ALP4B 21ATP4A 21BTP4
		19AP4	19AP4A 19AP4B 19AP4C 19AP4D		

*Connect external connector to chassis.

*Remove ion trap.

Directly Interchangeable TV Picture Tubes—(Continued)

Tube Number	Replace with	Tube Number	Replace with	Tube Number	Replace with
21AMP4	21AMP4A 21ACP4 21ACP4A	21CZP4	21DEP4	24AHP4	24ALP4
21ATP4	21ALP4 21ALP4A 21ALP4B 21ATP4A 21ATP4B 21BTP4	21DEP4	21DEP4A 21CZP4	24AJP4	24ATP4
21AUP4	21AUP4A 21AVP4 21AVP4A	21DKP4	21DKP4A	24ALP4	24AHP4
21AVP4	21AVP4A 21AVP4B 21AUP4 21AUP4A	21EP4A	21EP4B	24ANP4	24DP4 24DP4A 24YP4 24AEP4* 24ZP4*
21AYP4	21XP4 21XP4A	21FP4	21FP4A● 21KP4 21KP4A●	24AP4	24AP4A 24AP4B
21BAP4	21BNP4 21CVP4	21FP4A	21KP4A	24AP4B	24AP4 24AP4A
21BCP4	21BDP4	21KP4	21KP4A●	24ATP4	24AJP4
21BDP4	21BCP4	21WP4	21WP4A	24CP4	24CP4A 24ADP4 24QP4 24TP4 24VP4 24VP4A
21BNP4	21BAP4 21CVP4	21YP4	21YP4A		
21BTP4	21ALP4 21ALP4A 21ALP4B 21ATP4 21ATP4A 21ATP4B	21ZP4	21ZP4A●		
21CBP4	21CBP4A	22AP4	22AP4A	24DP4	24DP4A 24ANP4 24YP4 24AEP4* 24ZP4*
21CDP4	21CDP4A	22AP4A	22AP4		
21ECP4	21ECP4A	23CAP4	23TP4		
21CVP4	21BAP4 21BNP4	23ANP4	23ATP4	24QP4	24ADP4 24CP4 24CP4A 24TP4 24VP4 24VP4A
		23ATP4	23ANP4		
		23KP4	23KP4A	24VP4	24VP4A 24ADP4
		23XP4	23YP4		
		23YP4	23XP4		
		21ZP4	23YP4		
		24ADP4	24CP4 24CP4A 24QP4 24TP4 24VP4 24VP4A		

●Connect external connector to chassis.

*Remove Ion Trap.

Directly Interchangeable TV Picture Tubes (Continued)

Tube Number	Replaces with	Tube Number	Replaces with	Tube Number	Replaces with		
24VP4 (cont.)	24CP4	24XP4	24ADP4	24ZP4	24AEP4		
	24CP4A		24CP4		27EP4	27GP4	
	24QP4		24CP4A			27NP4*	
	24TP4		24QP4		27RP4*		
24VP4A	24VP4		24YP4	24TP4	27GP4	27EP4	
				24VP4			27NP4*
				24VP4A			27RP4*
				24AEP4*	27NP4	27RP4	
				24ANP4	27RP4	27NP4	
24CP4	24DP4		27SP4	27UP4			
24CP4A	24DP4A	27UP4	27SP4				
24QP4	24ZP4*						



*Connect external connector to chassis.

*Remove ion trap.

Greek Alphabet Designations

Name	Capital	Lower Case	Commonly used to designate
Alpha	A	α	Angles. Area. Coefficients
Beta	B	β	Angles. Flux density. Coefficients
Gamma	Γ	γ	Conductivity. Specific gravity
Delta	Δ	δ	Variation. Density
Epsilon	E	ϵ	Base of natural logarithms
Zeta	Z	ζ	Impedance. Coefficients. Coordinates
Eta	H	η	Hysteresis coefficient. Efficiency
Theta	Θ	θ	Temperature. Phase angle
Iota	I	ι	Unit vector.
Kappa	K	κ	Dielectric constant. Susceptibility
Lambda	Λ	λ	Wave length
Mu	M	μ	Micro. Amplification factor. Permeability
Nu	N	ν	Reluctivity
Xi	Ξ	ξ	Co-ordinates
Omicron	O	\omicron
Pi	Π	π	3.1416 (Ratio of circumference to diameter)
Rho	P	ρ	Resistivity
Sigma	Σ	σ	Sign of summation
Tau	T	τ	Time constant. Time phase displacement
Upsilon	Υ	υ
Phi	Φ	ϕ	Magnetic flux. Angles
Chi	X	χ	Electric susceptibility. Angles
Psi	Ψ	ψ	Dielectric flux. Phase difference
Omega	Ω	ω	Capital, ohms. Lower case, angular velocity

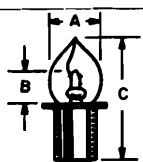
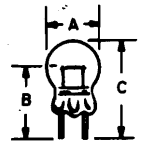
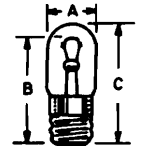
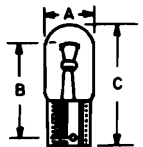
Pilot Lamp Data

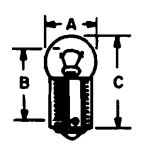
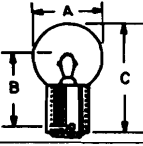
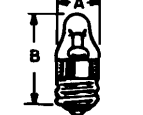
Bulb Silhouette	Maximum Size (See Chart Below)			Bulb No.	Base	Bulb Type	Lamp Numbers
	A	B	C				
	3/16"	1/4"	1 1/4"	B-3 1/2	S.C. Flange (Miniature)	Small Round	PR2 PR3 PR4 PR6 PR12
	3/16"	5/16"	1 1/4"	G-3 1/2	2-Pin (Miniature)	Small Round	12
	1 3/16"	1 3/16"	1 3/16"	T-3 1/4	Screw (Miniature)	Tubular	40 41 42 46 48 1892
	1 3/16"	3/4"	1 3/16"	T-3 1/4	Bayonet (Miniature)	Tubular	43 44 45 47 49 1490 1891
	3/16"	2 3/16"	1 5/16"	G-3 1/2	Screw (Miniature)	Small Round	50
	3/16"	1/2"	1 3/16"	G-3 1/2	Bayonet (Miniature)	Small Round	51
	3/16"	1/2"	1 1/4"	G-4 1/2	Bayonet (Miniature)	Large Round	55 57
	3/16"	3/8"	1 1/4"	G-5	Bayonet (Miniature)	Large Round	1458
	3/8"	—	1 3/16"	TL-3	Screw (Miniature)	Pinched Round	112 222

Pilot Lamp Data (Cont'd)

Lamp No.	Bead Color	Base (Miniature)	Bulb Type	Rating		Used For
				Volts	Amps.	
PR-2	Blue	Flange	B-3½	2.4	0.50	Flashlights
PR-3	Green	Flange	B-3½	3.6	0.50	Flashlights
PR-4	Yellow	Flange	B-3½	2.3	0.27	Flashlights
PR-6	Brown	Flange	B-3½	2.5	0.30	Flashlights
PR-12	White	Flange	B-3½	5.95	0.50	Flashlights
12	2-Pin	G-3½	6.3	0.15	Dials
40	Brown	Screw	T-3¼	6-8	0.15	Dials
41	White	Screw	T-3¼	2.5	0.5	Dials
42	Green	Screw	T-3¼	3.2	↓	Dials
43	White	Bayonet	T-3¼	2.5	0.5	Dials and Tuning Meters
44	Blue	Bayonet	T-3¼	6-8	0.25	Dials and Tuning Meters
45	Bayonet	T-3¼	3.2	↓	Dials
46*	Blue	Screw	T-3¼	6-8	0.25	Dials and Tuning Meters
47	Brown	Bayonet	T-3¼	6-9	0.15	Dials
48	Pink	Screw	T-3¼	2.0	0.06	Battery Set Dials
49	Pink	Bayonet	T-3¼	2.0	0.06	Battery Set Dials
50	White	Screw	G-3½	6-8	0.2	Auto-Radio Dials; Flashlights
51*	White	Bayonet	G-3½	6-8	0.2	Auto-Radio Dials; Panel Boards
55	White	Bayonet	G-4½	6-8	0.4	Auto-Radio Dials; Parking Lights
57	White	Bayonet	G-4½	14	0.24	Auto Radio Dials
112	Pink	Screw	TL-3	1.1	0.22	Flashlights
222	White	Screw	TL-3	2.2	0.25	Flashlights; Soldering Guns
1458	Bayonet	G-5	20.0	0.25	Dials
1490	White	Bayonet	T-3¼	3.2	0.15	Dials
1891	Pink	Bayonet	T-3½	14	0.23	Auto Radio Dials
1892	White	Screw	T-3½	14	0.12	Auto Panel Lights

*White in G.E. and Sylvania; Green in National Union Raytheon and Tung-Sol.
 †0.35 in G.E. and Sylvania; 0.5 in National Union Raytheon and Tung-Sol.
 *Have frosted bulb.

Neon Glow Lamps High Brightness

Lamp Number	Hours of Average Useful Life*	Maximum Overall Length	Base	Nominal Current in Ma.	Circuit Volts, AC or DC	Nominal Watts 110-125 V.
NE-2H	25,000	¾"	2" Wire Term.	1.7	110-125	1/5
NE-2J	25,000	1¼"	S.C. Mid. Flange	1.7	110-125	1/5
NE-2P	25,000	¾"	1" Wire Term.	1.7	110-125	1/5
NE-51H	25,000	1¼"	Min. Bay.	1.2	110-125	1/7

Standard Brightness

NE-2	25,000	1¼"	1" Wire Term.	0.5	110-125	1/17
NE-2D	25,000	1¼"	S.C. Mid. Flange	0.6	110-125	1/15
NE-2E	25,000	¾"	2" Wire Term.	0.6	110-125	1/15
NE-2M	25,000	¾"	1" Wire Term.	0.5	110-125	1/17
NE-7	7,500	1¼"	1½" Wire Term.	2.0	110-125	¼
NE-17	7,500	1½"	D.C. Bay	2.0	110-125	¼
NE-21	7,500	1½"	S.C. Bay	2.0	110-125	¼
NE-30	10,000	2¼"	Med. Screw	12.0	110-125	1
NE-34	10,000	3½"	Med. Screw	18.0	110-125	2
NE-42	10,000	3¼"	D.C. Bay	30.0	110-125	3
NE-45	7,500	1½"	Cand. Screw	2.0	110-125	¼
NE-48	7,500	1½"	D.C. Bay	2.0	110-125	¼
NE-51	15,000	1¼"	Min. Bay	0.3	110-125	1/25
NE-56	10,000	2¼"	Med. Screw	5.0	220-250	1
NE-57	7,500	1½"	Cand. Screw	2.0	110-125	¼
NE-58	7,500	1½"	Cand. Screw	2.0	220-250	½
NE-79	10,000	2"	D.C. Bay	12.0	110-125	1

Argon Glow Lamps

AR-1	1,000	3½"	Med. Screw	18.0	110-125	2
AR-3	150	1½"	Cand. Screw	3.5	110-125	¼
AR-4	150	1½"	D.C. Bay	3.5	110-125	¼
AR-9	50	1¼"	1" Wire Term.	0.3	110-125	1/25

*On A.C. unless otherwise noted. D-C life is approximately 60% of A-C values.

Interchangeable Batteries

Burgess	Eveready	Neda	Ray-O-Vac	RCA	Burgess	Eveready	Neda	Ray-O-Vac	RCA
1	935-635	14	1LP	VS035	8FL	745	21		VS008
10308*	W363F	716	5930C	VS127	8R	960P	23	191P	VS070
120	835		110LP		9R	1015E		41	
17GD60	759	413	AB82	VS022	920	815		710LP	
2	950		2LP	VS036	10338	799			
2F	W353	11	192PX	VS141	A30	W359	206	P430	VS014
2F4	718	1	698P	VS010	B3RT	702			
2F4L	747	16	698PL	VS011	B5	713	8	P551	VS129
2D	720	18	122P	VS069	B30	484	207	P5303	VS012
2FBP	W354	700	192S	VS101	C5	717	9	P751	VS065
2N6	246	1602	1602	VS305	D3	726	19	423PX	VS072
2R	950	13	2LP	VS036	D5	707	26	26	VS315
2TXX40	W370	412			D6	276	1603	1603	VS306
2U6	216	1604	1604	VS312	F2BP	W352	701	392S	VS100
20F	740	719	P9203	VS024	F2RT	704			
20F2	X125	720	P9403	VS025	F3	736	3	P93A	VS067
21R	964	20	8R	VS236	F4A50	W368	411	AB327	
210	1050		3LP		F48P	510S	915	941SC	VS040S
21308*	W365F	715	5830C	VS157	F4H	409	908	941	VS040C
2156	766T	702	2215C	VS137	F4PI	744	6	P694A	VS009
220	850		210LP		F4SC	510F	917	941C	
230	A100	13		VS336	F6A60P	753	401	AB994	VS019
2308*	W364F	723	5230C	VS126	6FA60P	757	406	AB909	VS058
2370ST	761T	712	423S	VS130	G3	746	7	P83A	VS002
2370PI	771	718	P231W	VS030	G5A42	W367	408	AB-794	VS038
4D4	274	1400			G6B60	752	400	AB-995	VS047
4F	742	4	194P	VS004	G6M60	754	402	AB-878	VS018
4FH	735	900	194S	VS106	H133	E133	1304		VS149
4FL		12	P94L	VS005	H233	E233	1300		VS400
4F2H	W357	901	398C	VS138	Hg-1R	E1	1100		VS143
4F4H	706	902	902	VS103	Hg-9	E9	1103	15M	VS313
4F6H	715	903	903	VS139	Hg-12R	E12	1101		VS144
4F6H	716	904	904	VS140	Hg-400R	E400	1106		VS145
4GA42	W366	407	AB944	VS053	Hg-401	E401	1102		VS401
4SD60	758	414	AB85	VS021	K10	417	224		
4TZ60	729	425	AB333	VS064	K15	420	225		
4156	763	710	2415S	VS102	K20	430	226		
422	750	704	342	VS134	K45	457	203	NSW45	VS082
432	751	705	443	VS142	M30	482	202	P7830	VS013
5156SC	778	708	2515C	VS131	N		910	716	VS073
5156PI	768	721	2515P	VS031	N60	490	204	4390	VS090
5308	W376	709	5530S	VS112	P6	226	1600	1600	VS300
532	703	706	453	VS133	P45	477	211P	NW45	VS218
5360	781	714	531R	VS028	P45M		211M	946	VS216-15
5540	773	713	755S	VS029	P60	479	214	214	VS219
6F	743	5	196P	VS007	S461	1461	907	641	VS039
6 Ign.	6 Ign.	905	6 Ign.-S	VS0065	S6D60	776	415	AB326	VS119
6 Ind.	6 Ind.	911	6RR		T5	W360	10	7CD5P	
6 Tel.	6GL	906	6 Tel.-C	VS042C	T5Z50	755	403	AB775	VS050
6TA60	W369	410	AB64	VS054	T5Z50P	785	431	431	VS060
7	912	24	400		T6Z60	756	405	AB601	VS057W
8F	741	17	198P		T6Z60P	756P	428		VS059
					U10	411	208	510P	VS083
					U15	412	215	215	VS084

*Available with plug-in terminal also.

Interchangeable Batteries—(Continued)

Burgess	Eveready	Neda	Ray-O-Vac	RCA	Burgess	Eveready	Neda	Ray-O-Vac	RCA
U15PF	412	915	XX45	467	200	4367	VS016
U20	413	210	520P	VS085	XX50	437	212	4375	VS217
U200	493	722	5200	VS093	XX69	W361	227	69N
U30	415	213	530CUH	VS086	Y10	504	10P
W20PI	99917	Y15	505	515P
W30PI	733	N30P	Y20	506	20P
XX9	239	1900	1900	VS304	Y20S	507
XX15	425P	PN15	Z	915	15	7R	VS034
XX22	433P	PN22	Z4	724	2	67R4	VS068
XX30	455	201	930	VS055	Z30	738	205	57R30P	VS015
XX30PI	455P	PN30F	Z30NX	W350	711	57R30S	VS114

Interchangeable Mercury Transistor Radio Batteries

Burgess	Eveready	Mallory	Philco	RCA	Zenith
HG9	E9	ZM-9	P9	VS-313	Z9
.....	E9N	DM-9N
H133	E133	TR-133	P133	VS-149
H146	E146	TR-146	P146	VS-312	Z146
H164	E164	TR-164	VS-164
.....	TR-175
H177	E177	TR-177	VS-309A
H233	E233	TR-233	P696	VS-400
.....	E42	RM-42
HQ401	E401	RM-401	VS-401
HQ630	E630	RM-630	P630	VS-147
HQ640	E640	RM-640	P640	VS-150
2U6	216	M-1604	VS-312	216

Resistor Color Code

EIA STANDARD RS-172

MILITARY STANDARD MIL-R-11C

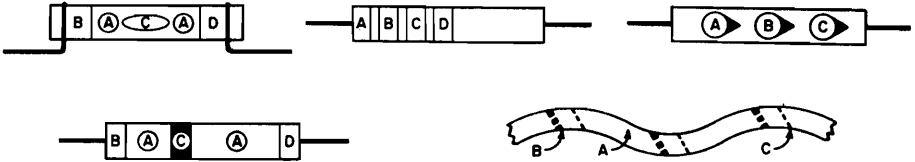

Color	1st Digit A	2nd Digit B	Multiplier C	Tolerance D
Black	0	0	1	—
Brown	1	1	10	—
Red	2	2	100	—
Orange	3	3	1,000	—
Yellow	4	4	10,000	—
Green	5	5	100,000	—
Blue	6	6	1,000,000	—
Violet	7	7	10,000,000	—
Gray	8	8	100,000,000	—
White	9	9	—	—
Gold	—	—	0.1	± 5%
Silver	—	—	0.01*	± 10%
No Color	—	—	*EIA ONLY. —	± 20%

INSULATION CODING

EIA: Insulated resistors with axial leads are designated by a background of any color except black. The usual color is natural tan. Noninsulated resistors with axial leads are designated by a black background color.

MILITARY (MIL): Same as EIA with the addition of: Noninsulated resistors with radial leads designated by a black background color or by a background the same color as the first significant figure of the resistance value.

Mica Capacitor Color Code

MILITARY STANDARD
MIL-C-5B

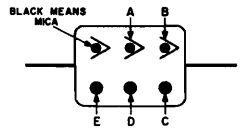

Color	Digits of Capacitance (μf)		Multiplier C	Tolerance % D	Characteristic. See table below E
	A	B			
Black	0	0	1	± 20	—
Brown	1	1	10	—	B
Red	2	2	100	± 2	C
Orange	3	3	1,000	—	D
Yellow	4	4	—	—	E
Green	5	5	—	—	F
Blue	6	6	—	—	—
Violet	7	7	—	—	—
Gray	8	8	—	—	—
White	9	9	—	—	—
Gold	—	—	0.1	± 5	—
Silver	—	—	0.01	± 10	—

DESCRIPTION OF CHARACTERISTIC

Characteristic	Temperature Coefficient (parts per million per °C)	Maximum Capacitance Drift	Minimum Insulation Resistance (megohms)
B	Not specified	Not specified	7500
C	± 200	± 0.5%	7500
D	± 100	± 0.3%	7500
E	+100 -20	± (0.1% + 0.1 μf)	7500
F	+70	± (0.05% + 0.1 μf)	7500

VOLTAGE RATING

(Indicated by dimensions rather than color coding)

Maximum Inches			Angle CM	Capacitance (μf)	Rating (v d-c)
Long	Wide	Thick			
3/16	3/16	1/16	15	5-510	300
—	—	—	—	5-510	500
3/16	1/8	1/16	20	560-1000	300
1/4	1/8	1/16	25	51-1000	500
3/16	3/16	3/16	30	560-3300	500
—	—	—	—	3600-6200	500
3/16	3/16	11/16	35	6800-10,000	300
—	—	—	—	3300-8200	500
1 1/2	1/4	1 1/2	40	9100-10,000	300

Mica Capacitor Color Code EIA STANDARD RS-153

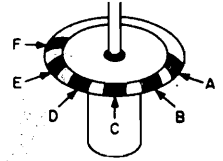
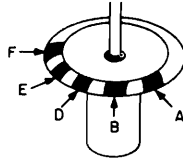
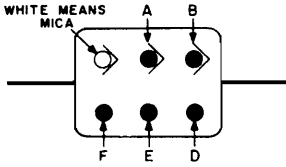

Color	Digits of Capacitance (μf)			Multiplier D	Tolerance % E*	Characteristic— See table below F
	A	B	C			
Black	0	0	0	1	± 20	A
Brown	1	1	1	10	± 1	B
Red	2	2	2	100	± 2	C
Orange	3	3	3	1,000	± 3	D
Yellow	4	4	4	10,000	—	E
Green	5	5	5	—	± 5	—
Blue	6	6	6	—	—	—
Violet	7	7	7	—	—	—
Gray	8	8	8	—	—	—
White	9	9	9	—	—	—
Gold	—	—	—	0.1	—	—
Silver	—	—	—	0.01	± 10	—

*or $\pm 1 \mu\text{f}$, whichever is greater.

DESCRIPTION OF CHARACTERISTIC

Characteristic	Temperature Coefficient (parts per million per $^{\circ}\text{C}$)	Maximum Capacitance Drift	Minimum Insulation Resistance (megohms)
A	± 1000	$\pm (5\% + 1 \mu\text{f})$	3000
B	± 500	$\pm (3\% + 1 \mu\text{f})$	6000
C	± 200	$\pm (0.5\% + 0.5 \mu\text{f})$	6000
D	± 100	$\pm (0.3\% + 0.1 \mu\text{f})$	6000
E	+100 -20	$\pm (0.1\% + 0.1 \mu\text{f})$	6000
—	—	—	—
—	—	—	—

VOLTAGE RATING

(Indicated by dimensions rather than color coding)

Maximum Inches			Style	Capacitance (μf)	Rating (v d-c)
Long	Wide	Thick			
$5\frac{1}{4}$	$1\frac{1}{2}$	$7\frac{1}{2}$	20	5-510 560-1000	500 300
$1\frac{1}{2}$	$1\frac{1}{2}$	$7\frac{1}{2}$	25	5-1000 1100-1500	500 300
$5\frac{3}{4}$	$5\frac{3}{4}$	$9\frac{1}{2}$	30	470-6200 Over 6200	500 300
$5\frac{3}{4}$	$5\frac{3}{4}$	$9\frac{1}{8}$	35	3300-6200 Over 6200	500 300
$1\frac{1}{2}$	$4\frac{1}{4}$	$11\frac{1}{2}$	40	100-2400 2700-7500 Over 7500	1000 500 300

Mica Capacitor Color Code Obsolete Style

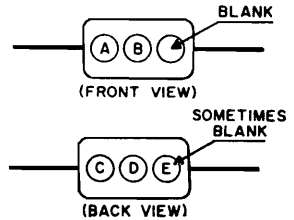
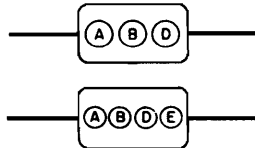
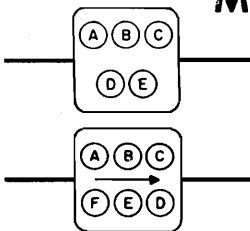

Dot Color	Digits of Capacitance (μf)			Multiplier D	Tolerance % E	Voltage Rating (v d-c) F
	A	B	C			
Black	0	0	0	1	± 20	—
Brown	1	1	1	10	± 1	100
Red	2	2	2	100	± 2	200
Orange	3	3	3	1,000	± 3	300
Yellow	4	4	4	10,000	± 4	400
Green	5	5	5	100,000	± 5	500
Blue	6	6	6	1,000,000	± 6	600
Violet	7	7	7	10,000,000	± 7	700
Gray	8	8	8	100,000,000	± 8	800
White	9	9	9	1,000,000,000	± 9	900
Gold	—	—	—	0.1	± 5	1,000
Silver	—	—	—	0.01	± 10	2,000
No Color	—	—	—	—	± 20	500

Ceramic Capacitor Color Code

EIA STANDARD RS-198

MILITARY STANDARD JAN-C-20A

Proposed Mil-C-20C

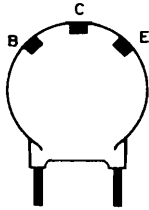

3-Dot Disc Capacitors (RETMA ONLY)
(Voltage rating is always 500 v., tolerance is always -0.)

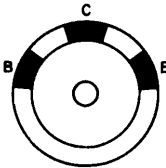

3-Dot Button Capacitors (EIA ONLY)

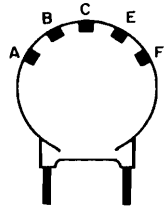

5-Dot Disc Capacitors (EIA ONLY)
(Voltage rating is always 500 v.)

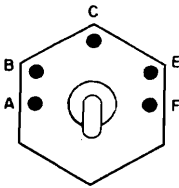

Feed Through Capacitors (EIA ONLY)

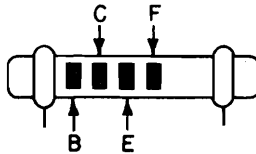

High Capacity Tubulars (Insulated or Non-Insulated)

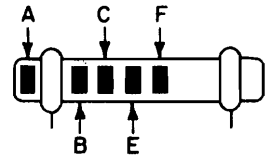

Temperature Compensating Tubulars

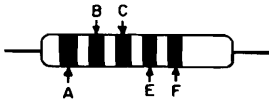

Tubular Capacitors (Voltage rating is always 500 v.)

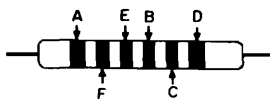

Tubular Capacitors (Old RMA)

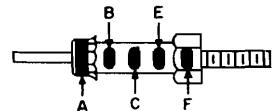

Stand-Off Capacitors (EIA ONLY)

Color	Digits of Capacitance (μmf)			Multiplier E	Tolerance F		Temp. Coef. A (Parts per million per $^{\circ}\text{C}.$)	
	B	C	D		10 μmf or less (μmf)	Over 10 μmf (%)	EIA	MILITARY
Black	0	0	0	1	± 2.0	$\pm 20^*$	0	0
Brown	1	1	1	10	$\pm 0.1^*$	± 1	- 33	- 30
Red	2	2	2	100	—	± 2	- 75	- 80
Orange	3	3	3	1,000	—	$\pm 2.5^*$	-150	-150
Yellow	4	4	4	10,000*	—	—	-220	-220
Green	5	5	5	—	± 0.5	± 5	-330	-330
Blue	6	6	6	—	—	—	-470	-470
Violet	7	7	7	—	—	—	-750	-750
Gray	8	8	8	0.01	± 0.25	—	+150 to -1500	+ 30
White	9	9	9	0.1	± 1.0	± 10	+100 to -750	+330*
Gold	—	—	—	—	—	—	—	+100

*EIA only

Paper Capacitor Color Code

MILITARY STANDARD MIL-C-91A

(Commercial codes are same except as noted)

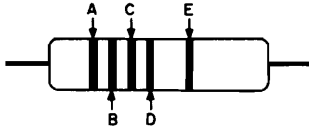

**Tubular Capacitors
(Commercial Only)**

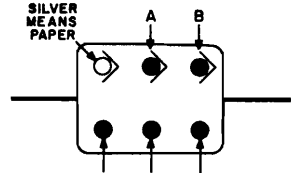

Rectangular Capacitors

Color	Digits of Capacitance (μf)		Multiplier C	Tolerance % D	Tubular Voltage Rating (v d-c) E	Temp. Rating °C and Characteristic F
	A	B				
Black	0	0	1	± 20	—	85-A
Brown	1	1	10	—	100	85-E
Red	2	2	100	—	200	—
Orange	3	3	1,000	± 30	300	—
Yellow	4	4	10,000	—	400	—
Green	5	5	—	—	500	—
Blue	6	6	—	—	600	—
Violet	7	7	—	—	700	—
Gray	8	8	—	—	800	—
White	9	9	—	—	900	—
Gold	—	—	—	—	1,000	—
Silver	—	—	—	± 10	—	—

VOLTAGE RATING FOR RECTANGULAR CAPACITORS

(Indicated by dimensions rather than color coding)

Maximum Dimensions (inches)			Style C/N	Capacitance (μf)	Voltage Rating (v d-c)
Length	Width	Thickness			
$5/16$	$15/32$	$1/32$	20	1000	400
				2000-6000	200
				10,000	120
$7/16$	$17/64$	$17/64$	22	2000-3000	400
				6000-10,000	300
				20,000	120
$9/16$	$33/64$	$9/32$	30	1000-2000	800
				3000	600
				6000-10,000	400
$11/16$	$33/64$	$11/32$	35	20,000	120
				3000	800
				6000-10,000	600
$1 1/4$	$41/64$	$9/32$	41	20,000	300
				30,000	120
				3000-6000	600
$1 15/16$	$49/64$	$11/32$	42	10,000	1000
				10,000-20,000	600
				30,000	400
				50,000	300
				100,000	120
$1 15/16$	$49/64$	$13/32$	43	10,000	1000
				20,000-30,000	600
				50,000-100,000	400
				200,000	120
				200,000	120

TYPOGRAPHICALLY MARKED TUBULAR CERAMICS

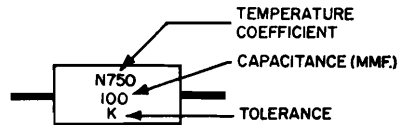

JAN LETTER	TOLERANCE	
	10 μf or Less	Over 10 μf
C	$\pm 0.25 \mu\text{f}$
D	$\pm 0.5 \mu\text{f}$
F	$\pm 1.0 \mu\text{f}$	$\pm 1\%$
G	$\pm 2.0 \mu\text{f}$	$\pm 2\%$
J	$\pm 5\%$
K	$\pm 10\%$
M	$\pm 20\%$

EIA Color Codes

The color codes on the preceding and two following pages are used by most radio and instrument manufacturers in the wiring of their products, and by parts manufacturers for identifying lead placement or resistor and capacitor values, ratings, and tolerances. These have been included for whatever help they may provide in identifying parts and

leads when trouble-shooting. Since all manufacturers do not use these codes, however, due caution must be observed to determine whether or not the set, instrument, or part under examination does or does not follow the code colors given here. A quick check with a voltmeter, ohmmeter, or continuity meter is usually all that is needed to establish this fact.

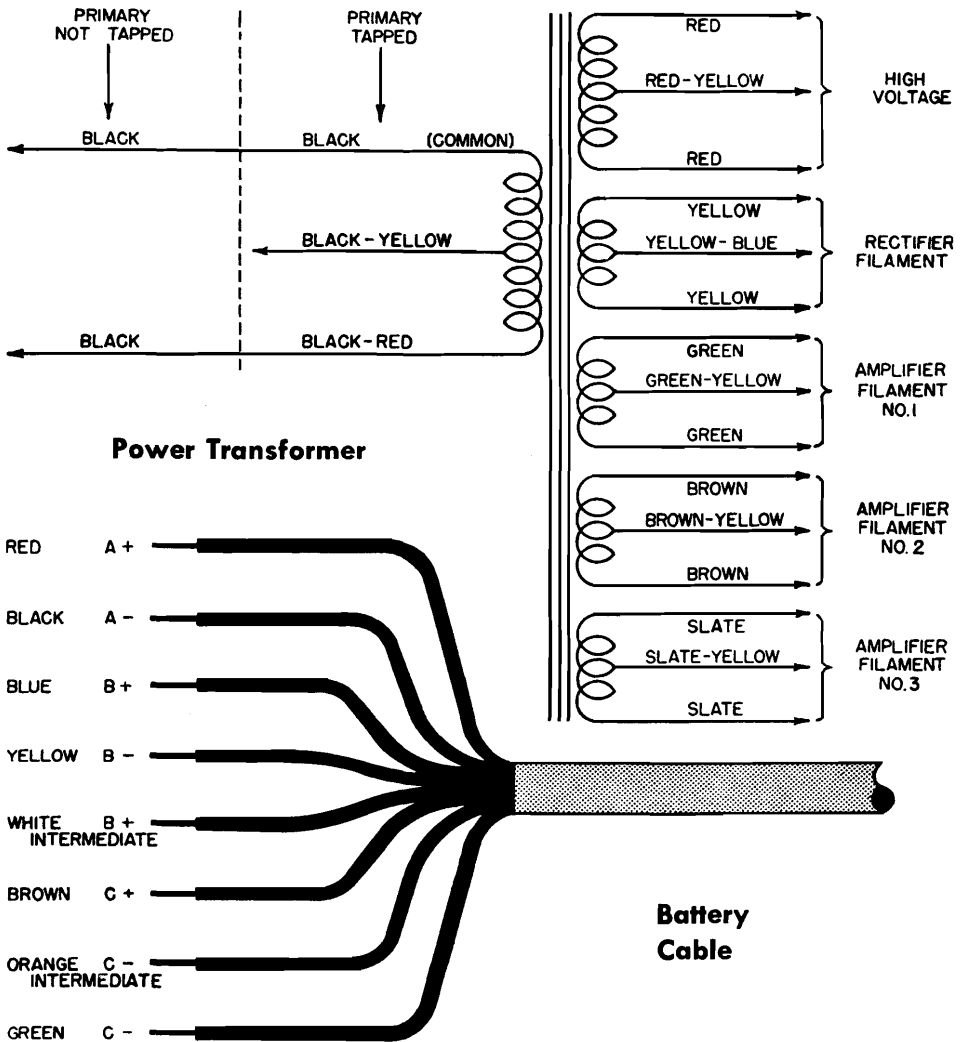

EIA Color Codes—(Continued)

Speaker Leads and Plug Connections

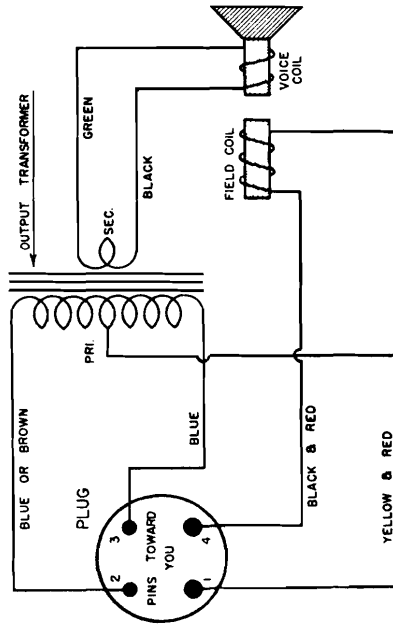
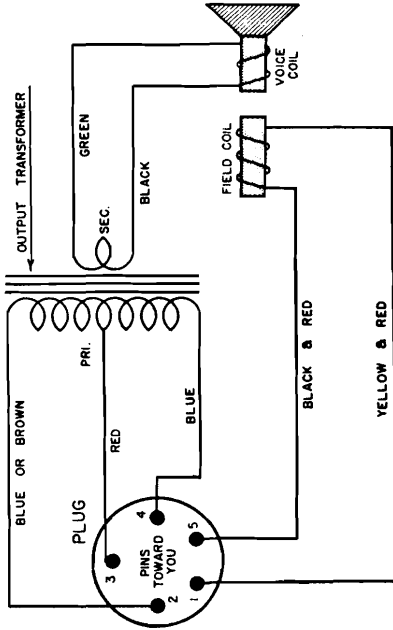

Speaker Leads and Plug Connections

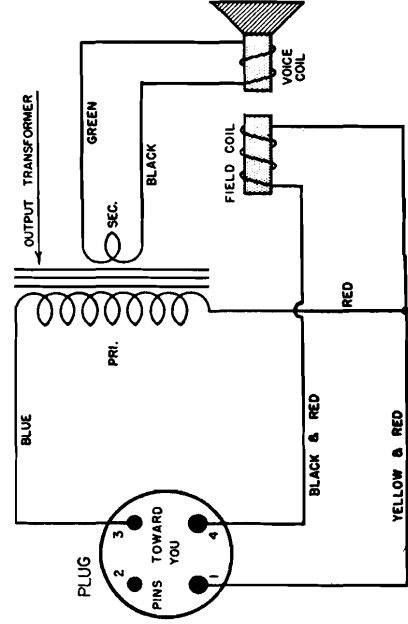
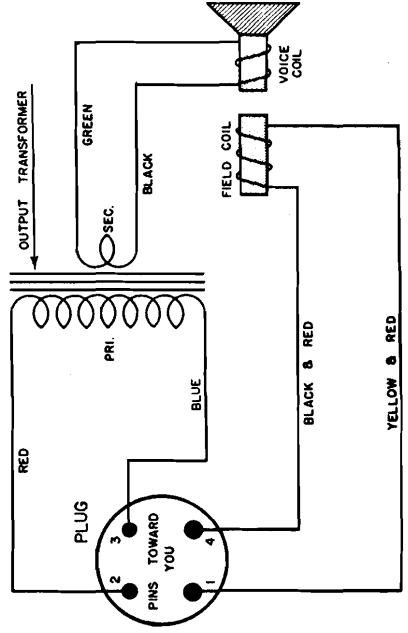

Speaker Lead Color Codes—(Continued)

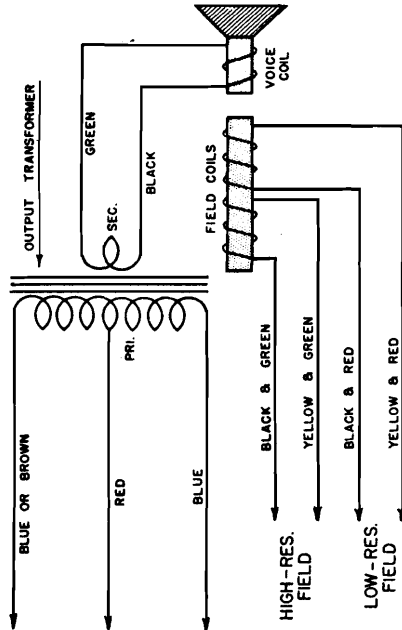
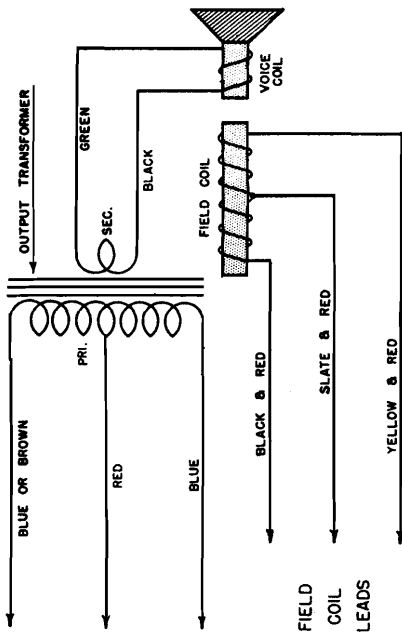

EIA Color Codes—(Continued)

I-F Transformers

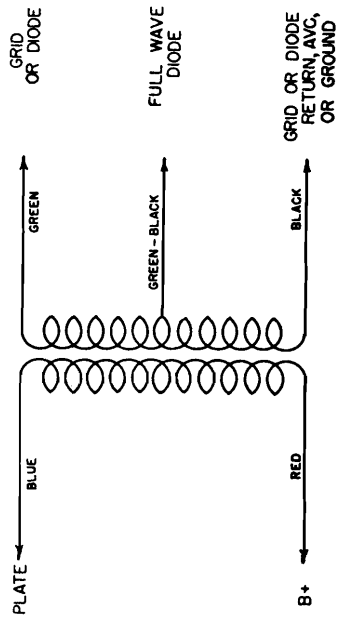

Audio & Output Transformers

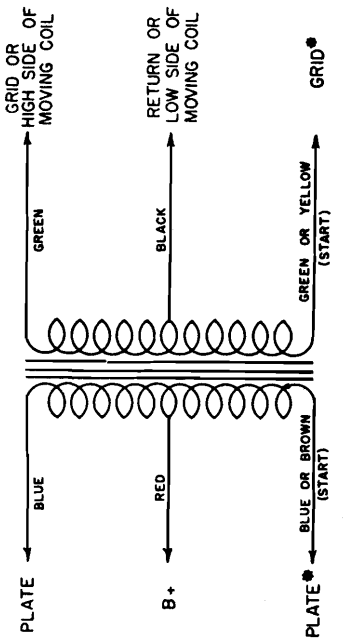

* FOUND ONLY ON PUSH-PULL PRIMARY OR SECONDARY WINDINGS

Abbreviations and Letter Symbols*











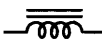
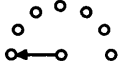

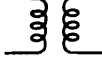





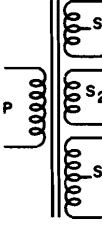









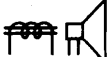
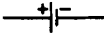



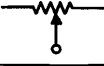
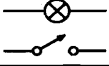

Many of the abbreviations given are in lower-case letters. Obviously, however, there will be occasions such as when the abbreviations are used in titles where the original word would have been capitalized. In these cases, the abbreviation should be similarly capitalized.

A two-word adjective expression should contain a hyphen.

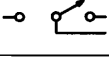

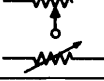
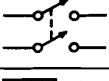

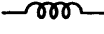

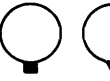







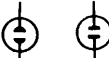

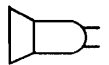









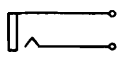

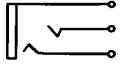

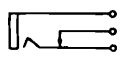





<i>Term</i>	<i>Abbreviation</i>	<i>Term</i>	<i>Abbreviation</i>
Admittance.....	<i>Y</i>	Low-frequency (adjective).....	<i>l-f</i>
Alternating-current (adjective)....	<i>a-c</i>	Low frequency (noun).....	<i>l.f.</i>
Alternating current (noun).....	<i>a.c.</i>	Magnetic field intensity.....	<i>H</i>
Ampere.....	<i>a</i>	Megacycle.....	<i>Mc</i>
Angular velocity ($2\pi f$).....	ω	Megohm.....	$M\Omega$
Antenna.....	<i>ant.</i>	Meter.....	<i>m</i>
Audio-frequency (adjective).....	<i>a-f</i>	Microampere.....	μa
Audio frequency (noun).....	<i>a.f.</i>	Microfarad (mfd).....	μf
Automatic volume control.....	<i>a.v.c.</i>	Microhenry.....	μh
Automatic volume expansion.....	<i>a.v.e.</i>	Micromicrofarad (mmfd).....	$\mu\mu f$
Capacitance.....	<i>C</i>	Microvolt.....	μv
Capacitive reactance.....	<i>X_C</i>	Microvolt per meter.....	$\mu v/m$
Centimeter.....	<i>cm</i>	Microwatt.....	μw
Conductance.....	<i>G</i>	Milliampere.....	<i>ma</i>
Continuous waves.....	<i>c.w.</i>	Millihenry.....	<i>mh</i>
Current.....	<i>I, i</i>	Millivolt.....	<i>mv</i>
Cycles per second.....	\sim	Millivolt per meter.....	<i>mv/m</i>
Decibel.....	<i>db</i>	Milliwatt.....	<i>mw</i>
Direct-current (adjective).....	<i>d-c</i>	Modulated continuous waves.....	<i>m.c.w.</i>
Direct current (noun).....	<i>d.c.</i>	Mutual inductance.....	<i>M</i>
Double cotton covered.....	<i>d.c.c.</i>	Ohm.....	Ω
Double pole, double throw.....	<i>d.p.d.t.</i>	Power.....	<i>P</i>
Double pole, single throw.....	<i>d.p.s.t.</i>	Power factor.....	<i>p.f.</i>
Double silk covered.....	<i>d.s.c.</i>	Radio-frequency (adjective).....	<i>r-f</i>
Electric field intensity.....	<i>E</i>	Radio frequency (noun).....	<i>r.f.</i>
Electromotive force.....	<i>e.m.f.</i>	Reactance.....	<i>X</i>
Frequency.....	<i>f</i>	Resistance.....	<i>R</i>
Frequency modulation.....	<i>f.m.</i>	Revolutions per minute.....	<i>r.p.m.</i>
Ground.....	<i>gnd.</i>	Root mean square.....	<i>r.m.s.</i>
Henry.....	<i>h</i>	Self-inductance.....	<i>L</i>
High-frequency (adjective).....	<i>h-f</i>	Short wave.....	<i>s.w.</i>
High frequency (noun).....	<i>h.f.</i>	Single cotton covered.....	<i>s.c.c.</i>
Impedance.....	<i>Z</i>	Single cotton enamel.....	<i>s.c.e.</i>
Inductance.....	<i>L</i>	Single pole, double throw.....	<i>s.p.d.t.</i>
Inductive reactance.....	<i>X_L</i>	Single pole, single throw.....	<i>s.p.s.t.</i>
Intermediate-frequency (adjective)	<i>i-f</i>	Single silk covered.....	<i>s.s.c.</i>
Intermediate frequency (noun)....	<i>i.f.</i>	Tuned radio frequency.....	<i>t.r.f.</i>
Interrupted continuous waves.....	<i>i.c.w.</i>	Ultra high frequency.....	<i>u.h.f.</i>
Kilocycle.....	<i>kc</i>	Vacuum tube voltmeter.....	<i>v.t.v.m</i>
Kilohm.....	$k\Omega$	Volt.....	<i>v</i>
Kilovolt.....	<i>kv</i>	Voltage.....	<i>E, e</i>
Kilovolt ampere.....	<i>kva</i>	Volt-Ohm-Milliammeter.....	<i>v.o.m.</i>
Kilowatt.....	<i>kw</i>	Watt.....	<i>w</i>

* See Page 23 for Transistor Symbols.

Schematic Symbols Used in Radio Diagrams

	ANTENNA (AERIAL)		IRON CORE CHOKE COIL		SWITCH (ROTARY OR SELECTOR)
	GROUND		R. F. TRANSFORMER (AIR CORE)		CRYSTAL DETECTOR
	ANTENNA (LOOP)		A. F. TRANSFORMER (IRON CORE)		LIGHTNING ARRESTER
	WIRING METHOD 1 CONNECTION		POWER TRANSFORMER P - 115 VOLT PRIMARY S ₁ - CENTER-TAPPED SECONDARY FOR FILAMENTS OF SIGNAL CIRCUIT TUBES S ₂ - SECONDARY FOR RECTIFIER TUBE FILAMENT S ₃ - CENTER-TAPPED HIGH-VOLTAGE SECONDARY		FUSE
	NO CONNECTION				PILOT LAMP
	WIRING METHOD 2 CONNECTION		FIXED CAPACITOR (MICA OR PAPER)		HEADPHONES
	NO CONNECTION				LOUDSPEAKER, P. M. DYNAMIC
	TERMINAL		FIXED CAPACITOR (ELECTROLYTIC)		LOUDSPEAKER, ELECTRODYNAMIC
	ONE CELL OR "A" BATTERY		ADJUSTABLE OR VARIABLE CAPACITOR		PHONO PICK-UP
	MULTI-CELL OR "B" BATTERY		ADJUSTABLE OR VARIABLE CAPACITORS (GANDED)		VACUUM TUBE HEATER OR FILAMENT
	RESISTOR		I. F. TRANSFORMER (DOUBLE-TUNED)		VACUUM TUBE CATHODE
	POTENTIOMETER (VOLUME CONTROL)		POWER SWITCH S. P. S. T.		VACUUM TUBE GRID
	TAPPED RESISTOR OR VOLTAGE DIVIDER		SWITCH S. P. D. T.		VACUUM TUBE PLATE
	RHEOSTAT		SWITCH D. P. S. T.		3-ELEMENT VACUUM TUBE (TRIODE)
	AIR CORE CHOKE COIL		SWITCH D. P. D. T.		ALIGNING KEY OCTAL BASE TUBE

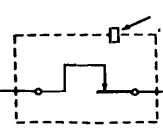
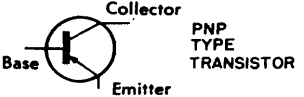
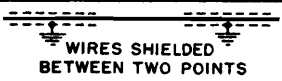
Schematic Symbols Used in Radio Diagrams

	SLIDE SWITCH		FILAMENT LAMPS		PHONE PLUG
	MULTI-CONTACT SWITCH		NEON LAMPS		PHONO PLUG
	GENERAL MICROPHONE		METER	 Male	INTER-CONNECTING PLUG
	CAPACITOR MICROPHONE		METER	 Female	INTER-CONNECTING PLUG
	DYNAMIC MICROPHONE		VARIABLE CORE INDUCTOR		LINE PLUG
	CRYSTAL MICROPHONE				PIEZOELECTRIC CRYSTAL FREQUENCY DETERMINING
	PHONE JACK		VARIABLE CORE INDUCTOR		PIEZOELECTRIC CRYSTAL FREQUENCY DETERMINING
	PHONE JACK		AIR CORE INDUCTOR		PIEZOELECTRIC CRYSTAL MONAURAL PHONO CARTRIDGE
	PHONE JACK				PIEZOELECTRIC CRYSTAL STEREO PHONO CARTRIDGE
	PHONO JACK		IRON CORE INDUCTOR		RECTIFIER OR DIODE
	SHIELDED PAIR SHIELD		POWDERED-IRON CORE INDUCTOR		ZENER DIODE
	SHIELDED WIRE SHIELD		RELAYS		DOUBLE ANODE
	SHIELDED ASSEMBLY				SILICON CONTROLLED RECTIFIER
	COMMON GROUND		CIRCUIT BREAKER		PNP TYPE TRANSISTOR
	WIRES SHIELDED BETWEEN TWO POINTS				NPN TYPE TRANSISTOR

Common Logarithms

N	0	1	2	3	4	5	6	7	8	9	N
10	0000	0043	0086	0128	0170	0212	0253	0294	0334	0374	10
11	0414	0453	0492	0531	0569	0607	0645	0682	0719	0755	11
12	0792	0828	0864	0899	0934	0969	1004	1038	1072	1106	12
13	1139	1173	1206	1239	1271	1303	1335	1367	1399	1430	13
14	1461	1492	1523	1553	1584	1614	1644	1673	1703	1732	14
15	1761	1790	1818	1847	1875	1903	1931	1959	1987	2014	15
16	2041	2068	2095	2122	2148	2175	2201	2227	2253	2279	16
17	2304	2330	2355	2380	2405	2430	2455	2480	2504	2529	17
18	2553	2577	2601	2625	2648	2672	2695	2718	2742	2765	18
19	2788	2810	2833	2856	2878	2900	2923	2945	2967	2989	19
20	3010	3032	3054	3075	3096	3118	3139	3160	3181	3201	20
21	3222	3243	3263	3284	3304	3324	3345	3365	3385	3404	21
22	3424	3444	3464	3483	3502	3522	3541	3560	3579	3598	22
23	3617	3636	3655	3674	3692	3711	3729	3747	3766	3784	23
24	3802	3820	3838	3856	3874	3892	3909	3927	3945	3962	24
25	3979	3997	4014	4031	4048	4065	4082	4099	4116	4133	25
26	4150	4166	4183	4200	4216	4232	4249	4265	4281	4298	26
27	4314	4330	4346	4362	4378	4393	4409	4425	4440	4456	27
28	4472	4487	4502	4518	4533	4548	4564	4579	4594	4609	28
29	4624	4639	4654	4669	4683	4698	4713	4728	4742	4757	29
30	4771	4786	4800	4814	4829	4843	4857	4871	4886	4900	30
31	4914	4928	4942	4955	4969	4983	4997	5011	5024	5038	31
32	5051	5065	5079	5092	5105	5119	5132	5145	5159	5172	32
33	5185	5198	5211	5224	5237	5250	5263	5276	5289	5302	33
34	5315	5328	5340	5353	5366	5378	5391	5403	5416	5428	34
35	5441	5453	5465	5478	5490	5502	5514	5527	5539	5551	35
36	5563	5575	5587	5599	5611	5623	5635	5647	5658	5670	36
37	5682	5694	5705	5717	5729	5740	5752	5763	5775	5786	37
38	5798	5809	5821	5832	5843	5855	5866	5877	5888	5899	38
39	5911	5922	5933	5944	5955	5966	5977	5988	5999	6010	39
40	6021	6031	6042	6053	6064	6075	6085	6096	6107	6117	40
41	6128	6138	6149	6160	6170	6180	6191	6201	6212	6222	41
42	6232	6243	6253	6263	6274	6284	6294	6304	6314	6325	42
43	6335	6345	6355	6365	6375	6385	6395	6405	6415	6425	43
44	6435	6444	6454	6464	6474	6484	6493	6503	6513	6522	44
45	6532	6542	6551	6561	6571	6580	6590	6599	6609	6618	45
46	6628	6637	6646	6656	6665	6675	6684	6693	6702	6712	46
47	6721	6730	6739	6749	6758	6767	6776	6785	6794	6803	47
48	6812	6821	6830	6839	6848	6857	6866	6875	6884	6893	48
49	6902	6911	6920	6928	6937	6946	6955	6964	6972	6981	49
50	6990	6998	7007	7016	7024	7033	7042	7050	7059	7067	50
51	7076	7084	7093	7101	7110	7118	7126	7135	7143	7152	51
52	7160	7168	7177	7185	7193	7202	7210	7218	7226	7235	52
53	7243	7251	7259	7267	7275	7284	7292	7300	7308	7316	53
54	7324	7332	7340	7348	7356	7364	7372	7380	7388	7396	54
N	0	1	2	3	4	5	6	7	8	9	N

Common Logarithms (Continued)

N	0	1	2	3	4	5	6	7	8	9	N
55	7404	7412	7419	7427	7435	7443	7451	7459	7466	7474	55
56	7482	7490	7497	7505	7513	7520	7528	7536	7543	7551	56
57	7559	7566	7574	7582	7589	7597	7604	7612	7619	7627	57
58	7634	7642	7649	7657	7664	7672	7679	7686	7694	7701	58
59	7709	7716	7723	7731	7738	7745	7752	7760	7767	7774	59
60	7782	7789	7796	7803	7810	7818	7825	7832	7839	7846	60
61	7853	7860	7868	7875	7882	7889	7896	7903	7910	7917	61
62	7924	7931	7938	7945	7952	7959	7966	7973	7980	7987	62
63	7993	8000	8007	8014	8021	8028	8035	8041	8048	8055	63
64	8062	8069	8075	8082	8089	8096	8102	8109	8116	8122	64
65	8129	8136	8142	8149	8156	8162	8169	8176	8182	8189	65
66	8195	8202	8209	8215	8222	8228	8235	8241	8248	8254	66
67	8261	8267	8274	8280	8287	8293	8299	8306	8312	8319	67
68	8325	8331	8338	8344	8351	8357	8363	8370	8376	8382	68
69	8388	8395	8401	8407	8414	8420	8426	8432	8439	8445	69
70	8451	8457	8463	8470	8476	8482	8488	8494	8500	8506	70
71	8513	8519	8525	8531	8537	8543	8549	8555	8561	8567	71
72	8573	8579	8585	8591	8597	8603	8609	8615	8621	8627	72
73	8633	8639	8645	8651	8657	8663	8669	8675	8681	8686	73
74	8692	8698	8704	8710	8716	8722	8727	8733	8739	8745	74
75	8751	8756	8762	8768	8774	8779	8785	8791	8797	8802	75
76	8808	8814	8820	8825	8831	8837	8842	8848	8854	8859	76
77	8865	8871	8876	8882	8887	8893	8899	8904	8910	8915	77
78	8921	8927	8932	8938	8943	8949	8954	8960	8965	8971	78
79	8976	8982	8987	8993	8998	9004	9009	9015	9020	9025	79
80	9031	9036	9042	9047	9053	9058	9063	9069	9074	9079	80
81	9085	9090	9096	9101	9106	9112	9117	9122	9128	9133	81
82	9138	9143	9149	9154	9159	9165	9170	9175	9180	9186	82
83	9191	9196	9201	9206	9212	9217	9222	9227	9232	9238	83
84	9243	9248	9253	9258	9263	9269	9274	9279	9284	9289	84
85	9294	9299	9304	9309	9315	9320	9325	9330	9335	9340	85
86	9345	9350	9355	9360	9365	9370	9375	9380	9385	9390	86
87	9395	9400	9405	9410	9415	9420	9425	9430	9435	9440	87
88	9445	9450	9455	9460	9465	9469	9474	9479	9484	9489	88
89	9494	9499	9504	9509	9513	9518	9523	9528	9533	9538	89
90	9542	9547	9552	9557	9562	9566	9571	9576	9581	9586	90
91	9590	9595	9600	9605	9609	9614	9619	9624	9628	9633	91
92	9638	9643	9647	9652	9657	9661	9666	9671	9675	9680	92
93	9685	9689	9694	9699	9703	9708	9713	9717	9722	9727	93
94	9731	9736	9741	9745	9750	9754	9759	9763	9768	9773	94
95	9777	9782	9786	9791	9795	9800	9805	9809	9814	9818	95
96	9823	9827	9832	9836	9841	9845	9850	9854	9859	9863	96
97	9868	9872	9877	9881	9886	9890	9894	9899	9903	9908	97
98	9912	9917	9921	9926	9930	9934	9939	9943	9948	9952	98
99	9956	9961	9965	9969	9974	9978	9983	9987	9991	9996	99
N	0	1	2	3	4	5	6	7	8	9	N

Natural Sines, Cosines, and Tangents
0°-14.9°

Degs.	Function	0.0°	0.1°	0.2°	0.3°	0.4°	0.5°	0.6°	0.7°	0.8°	0.9°
0	sin	0.0000	0.0017	0.0035	0.0052	0.0070	0.0087	0.0105	0.0122	0.0140	0.0157
	cos	1.0000	1.0000	1.0000	1.0000	1.0000	1.0000	0.9999	0.9999	0.9999	0.9999
	tan	0.0000	0.0017	0.0035	0.0052	0.0070	0.0087	0.0105	0.0122	0.0140	0.0157
1	sin	0.0175	0.0192	0.0209	0.0227	0.0244	0.0262	0.0279	0.0297	0.0314	0.0332
	cos	0.9998	0.9998	0.9998	0.9997	0.9997	0.9997	0.9996	0.9996	0.9995	0.9995
	tan	0.0175	0.0192	0.0209	0.0227	0.0244	0.0262	0.0279	0.0297	0.0314	0.0332
2	sin	0.0349	0.0366	0.0384	0.0401	0.0419	0.0436	0.0454	0.0471	0.0488	0.0506
	cos	0.9994	0.9993	0.9993	0.9992	0.9991	0.9990	0.9990	0.9989	0.9988	0.9987
	tan	0.0349	0.0367	0.0384	0.0402	0.0419	0.0437	0.0454	0.0472	0.0489	0.0507
3	sin	0.0523	0.0541	0.0558	0.0576	0.0593	0.0610	0.0628	0.0645	0.0663	0.0680
	cos	0.9986	0.9985	0.9984	0.9983	0.9982	0.9981	0.9980	0.9979	0.9978	0.9977
	tan	0.0524	0.0542	0.0559	0.0577	0.0594	0.0612	0.0629	0.0647	0.0664	0.0682
4	sin	0.0698	0.0715	0.0732	0.0750	0.0767	0.0785	0.0802	0.0819	0.0837	0.0854
	cos	0.9976	0.9974	0.9973	0.9972	0.9971	0.9969	0.9968	0.9966	0.9965	0.9963
	tan	0.0699	0.0717	0.0734	0.0752	0.0769	0.0787	0.0805	0.0822	0.0840	0.0857
5	sin	0.0872	0.0889	0.0906	0.0924	0.0941	0.0958	0.0976	0.0993	0.1011	0.1028
	cos	0.9962	0.9960	0.9959	0.9957	0.9956	0.9954	0.9952	0.9951	0.9949	0.9947
	tan	0.0875	0.0892	0.0910	0.0928	0.0945	0.0963	0.0981	0.0998	0.1016	0.1033
6	sin	0.1045	0.1063	0.1080	0.1097	0.1115	0.1132	0.1149	0.1167	0.1184	0.1201
	cos	0.9945	0.9943	0.9942	0.9940	0.9938	0.9936	0.9934	0.9932	0.9930	0.9928
	tan	0.1051	0.1069	0.1086	0.1104	0.1122	0.1139	0.1157	0.1175	0.1192	0.1210
7	sin	0.1219	0.1236	0.1253	0.1271	0.1288	0.1305	0.1323	0.1340	0.1357	0.1374
	cos	0.9925	0.9923	0.9921	0.9919	0.9917	0.9914	0.9912	0.9910	0.9907	0.9905
	tan	0.1228	0.1246	0.1263	0.1281	0.1299	0.1317	0.1334	0.1352	0.1370	0.1388
8	sin	0.1392	0.1409	0.1426	0.1444	0.1461	0.1478	0.1495	0.1513	0.1530	0.1547
	cos	0.9903	0.9900	0.9898	0.9895	0.9893	0.9890	0.9888	0.9885	0.9882	0.9880
	tan	0.1405	0.1423	0.1441	0.1459	0.1477	0.1495	0.1512	0.1530	0.1548	0.1566
9	sin	0.1564	0.1582	0.1599	0.1616	0.1633	0.1650	0.1668	0.1685	0.1702	0.1719
	cos	0.9877	0.9874	0.9871	0.9869	0.9866	0.9863	0.9860	0.9857	0.9854	0.9851
	tan	0.1584	0.1602	0.1620	0.1638	0.1655	0.1673	0.1691	0.1709	0.1727	0.1745
10	sin	0.1736	0.1754	0.1771	0.1788	0.1805	0.1822	0.1840	0.1857	0.1874	0.1891
	cos	0.9848	0.9845	0.9842	0.9839	0.9836	0.9833	0.9829	0.9826	0.9823	0.9820
	tan	0.1763	0.1781	0.1799	0.1817	0.1835	0.1853	0.1871	0.1890	0.1908	0.1926
11	sin	0.1908	0.1925	0.1942	0.1959	0.1977	0.1994	0.2011	0.2028	0.2045	0.2062
	cos	0.9816	0.9813	0.9810	0.9806	0.9803	0.9799	0.9796	0.9792	0.9789	0.9785
	tan	0.1944	0.1962	0.1980	0.1998	0.2016	0.2035	0.2053	0.2071	0.2089	0.2107
12	sin	0.2079	0.2096	0.2113	0.2130	0.2147	0.2164	0.2181	0.2198	0.2215	0.2232
	cos	0.9781	0.9778	0.9774	0.9770	0.9767	0.9763	0.9759	0.9755	0.9751	0.9748
	tan	0.2126	0.2144	0.2162	0.2180	0.2199	0.2217	0.2235	0.2254	0.2272	0.2290
13	sin	0.2250	0.2267	0.2284	0.2300	0.2318	0.2334	0.2351	0.2368	0.2385	0.2402
	cos	0.9744	0.9740	0.9736	0.9732	0.9728	0.9724	0.9720	0.9715	0.9711	0.9707
	tan	0.2309	0.2327	0.2345	0.2364	0.2382	0.2401	0.2419	0.2438	0.2456	0.2475
14	sin	0.2419	0.2436	0.2453	0.2470	0.2487	0.2504	0.2521	0.2538	0.2554	0.2571
	cos	0.9703	0.9699	0.9694	0.9690	0.9686	0.9681	0.9677	0.9673	0.9668	0.9664
	tan	0.2493	0.2512	0.2530	0.2549	0.2568	0.2586	0.2605	0.2623	0.2642	0.2661
Degs.	Function	0'	6'	12'	18'	24'	30'	36'	42'	48'	54'

Natural Sines, Cosines, and Tangents—(Continued)

15°-29.9°

Degs.	Function	0.0°	0.1°	0.2°	0.3°	0.4°	0.5°	0.6°	0.7°	0.8°	0.9°
15	sin	0.2588	0.2605	0.2622	0.2639	0.2656	0.2672	0.2689	0.2706	0.2723	0.2740
	cos	0.9659	0.9655	0.9650	0.9646	0.9641	0.9636	0.9632	0.9627	0.9622	0.9617
	tan	0.2679	0.2698	0.2717	0.2736	0.2754	0.2773	0.2792	0.2811	0.2830	0.2849
16	sin	0.2756	0.2773	0.2790	0.2807	0.2823	0.2840	0.2857	0.2874	0.2890	0.2907
	cos	0.9613	0.9608	0.9603	0.9598	0.9593	0.9588	0.9583	0.9578	0.9573	0.9568
	tan	0.2867	0.2886	0.2905	0.2924	0.2943	0.2962	0.2981	0.3000	0.3019	0.3038
17	sin	0.2924	0.2940	0.2957	0.2974	0.2990	0.3007	0.3024	0.3040	0.3057	0.3074
	cos	0.9563	0.9558	0.9553	0.9548	0.9542	0.9537	0.9532	0.9527	0.9521	0.9516
	tan	0.3057	0.3076	0.3096	0.3115	0.3134	0.3153	0.3172	0.3191	0.3211	0.3230
18	sin	0.3090	0.3107	0.3123	0.3140	0.3156	0.3173	0.3190	0.3206	0.3223	0.3239
	cos	0.9511	0.9505	0.9500	0.9494	0.9489	0.9483	0.9478	0.9472	0.9466	0.9461
	tan	0.3249	0.3269	0.3288	0.3307	0.3327	0.3346	0.3365	0.3385	0.3404	0.3424
19	sin	0.3256	0.3272	0.3289	0.3305	0.3322	0.3338	0.3355	0.3371	0.3387	0.3404
	cos	0.9455	0.9449	0.9444	0.9438	0.9432	0.9426	0.9421	0.9415	0.9409	0.9403
	tan	0.3443	0.3463	0.3482	0.3502	0.3522	0.3541	0.3561	0.3581	0.3600	0.3620
20	sin	0.3420	0.3437	0.3453	0.3469	0.3486	0.3502	0.3518	0.3535	0.3551	0.3567
	cos	0.9397	0.9391	0.9385	0.9379	0.9373	0.9367	0.9361	0.9354	0.9348	0.9342
	tan	0.3640	0.3659	0.3679	0.3699	0.3719	0.3739	0.3759	0.3779	0.3799	0.3819
21	sin	0.3584	0.3600	0.3616	0.3633	0.3649	0.3665	0.3681	0.3697	0.3714	0.3730
	cos	0.9336	0.9330	0.9323	0.9317	0.9311	0.9304	0.9298	0.9291	0.9285	0.9278
	tan	0.3839	0.3859	0.3879	0.3899	0.3919	0.3939	0.3959	0.3979	0.4000	0.4020
22	sin	0.3746	0.3762	0.3778	0.3795	0.3811	0.3827	0.3843	0.3859	0.3875	0.3891
	cos	0.9272	0.9265	0.9259	0.9252	0.9245	0.9239	0.9232	0.9225	0.9219	0.9212
	tan	0.4040	0.4061	0.4081	0.4101	0.4122	0.4142	0.4163	0.4183	0.4204	0.4224
23	sin	0.3907	0.3923	0.3939	0.3955	0.3971	0.3987	0.4003	0.4019	0.4035	0.4051
	cos	0.9205	0.9198	0.9191	0.9184	0.9178	0.9171	0.9164	0.9157	0.9150	0.9143
	tan	0.4245	0.4265	0.4286	0.4307	0.4327	0.4348	0.4369	0.4390	0.4411	0.4431
24	sin	0.4067	0.4083	0.4099	0.4115	0.4131	0.4147	0.4163	0.4179	0.4195	0.4210
	cos	0.9135	0.9128	0.9121	0.9114	0.9107	0.9100	0.9092	0.9085	0.9078	0.9070
	tan	0.4452	0.4473	0.4494	0.4515	0.4536	0.4557	0.4578	0.4599	0.4621	0.4642
25	sin	0.4226	0.4242	0.4258	0.4274	0.4289	0.4305	0.4321	0.4337	0.4352	0.4368
	cos	0.9063	0.9056	0.9048	0.9041	0.9033	0.9026	0.9018	0.9011	0.9003	0.8996
	tan	0.4663	0.4684	0.4706	0.4727	0.4748	0.4770	0.4791	0.4813	0.4834	0.4856
26	sin	0.4384	0.4399	0.4415	0.4431	0.4446	0.4462	0.4478	0.4493	0.4509	0.4524
	cos	0.8988	0.8980	0.8973	0.8965	0.8957	0.8949	0.8942	0.8934	0.8926	0.8918
	tan	0.4877	0.4899	0.4921	0.4942	0.4964	0.4986	0.5008	0.5029	0.5051	0.5073
27	sin	0.4540	0.4555	0.4571	0.4586	0.4602	0.4617	0.4633	0.4648	0.4664	0.4679
	cos	0.8910	0.8902	0.8894	0.8886	0.8878	0.8870	0.8862	0.8854	0.8846	0.8838
	tan	0.5095	0.5117	0.5139	0.5161	0.5184	0.5206	0.5228	0.5250	0.5272	0.5295
28	sin	0.4695	0.4710	0.4726	0.4741	0.4756	0.4772	0.4787	0.4802	0.4818	0.4833
	cos	0.8829	0.8821	0.8813	0.8805	0.8796	0.8788	0.8780	0.8771	0.8763	0.8755
	tan	0.5317	0.5340	0.5362	0.5384	0.5407	0.5430	0.5452	0.5475	0.5498	0.5520
29	sin	0.4848	0.4863	0.4879	0.4894	0.4909	0.4924	0.4939	0.4955	0.4970	0.4985
	cos	0.8746	0.8738	0.8729	0.8721	0.8712	0.8704	0.8695	0.8686	0.8678	0.8669
	tan	0.5543	0.5566	0.5589	0.5612	0.5635	0.5658	0.5681	0.5704	0.5727	0.5750
Degs.	Function	0'	6'	12'	18'	24'	30'	36'	42'	48'	54'

Natural Sines, Cosines, and Tangents—(Continued)

30°-44.9°

Degs.	Function	0.0°	0.1°	0.2°	0.3°	0.4°	0.5°	0.6°	0.7°	0.8°	0.9°
30	sin	0.5000	0.5015	0.5030	0.5045	0.5060	0.5075	0.5090	0.5105	0.5120	0.5135
	cos	0.8660	0.8652	0.8643	0.8634	0.8625	0.8616	0.8607	0.8599	0.8590	0.8581
	tan	0.5774	0.5797	0.5820	0.5844	0.5867	0.5890	0.5914	0.5938	0.5961	0.5985
31	sin	0.5150	0.5165	0.5180	0.5195	0.5210	0.5225	0.5240	0.5255	0.5270	0.5284
	cos	0.8572	0.8563	0.8554	0.8545	0.8536	0.8526	0.8517	0.8508	0.8499	0.8490
	tan	0.6009	0.6032	0.6056	0.6080	0.6104	0.6128	0.6152	0.6176	0.6200	0.6224
32	sin	0.5299	0.5314	0.5329	0.5344	0.5358	0.5373	0.5388	0.5402	0.5417	0.5432
	cos	0.8480	0.8471	0.8462	0.8453	0.8443	0.8434	0.8425	0.8415	0.8406	0.8396
	tan	0.6249	0.6273	0.6297	0.6322	0.6346	0.6371	0.6395	0.6420	0.6445	0.6469
33	sin	0.5446	0.5461	0.5476	0.5490	0.5505	0.5519	0.5534	0.5548	0.5563	0.5577
	cos	0.8387	0.8377	0.8368	0.8358	0.8348	0.8339	0.8329	0.8320	0.8310	0.8300
	tan	0.6494	0.6519	0.6544	0.6569	0.6594	0.6619	0.6644	0.6669	0.6694	0.6720
34	sin	0.5592	0.5606	0.5621	0.5635	0.5650	0.5664	0.5678	0.5693	0.5707	0.5721
	cos	0.8290	0.8281	0.8271	0.8261	0.8251	0.8241	0.8231	0.8221	0.8211	0.8202
	tan	0.6745	0.6771	0.6796	0.6822	0.6847	0.6873	0.6899	0.6924	0.6950	0.6976
35	sin	0.5736	0.5750	0.5764	0.5779	0.5793	0.5807	0.5821	0.5835	0.5850	0.5864
	cos	0.8192	0.8181	0.8171	0.8161	0.8151	0.8141	0.8131	0.8121	0.8111	0.8100
	tan	0.7002	0.7028	0.7054	0.7080	0.7107	0.7133	0.7159	0.7186	0.7212	0.7239
36	sin	0.5878	0.5892	0.5906	0.5920	0.5934	0.5948	0.5962	0.5976	0.5990	0.6004
	cos	0.8090	0.8080	0.8070	0.8059	0.8049	0.8039	0.8028	0.8018	0.8007	0.7997
	tan	0.7265	0.7292	0.7319	0.7346	0.7373	0.7400	0.7427	0.7454	0.7481	0.7508
37	sin	0.6018	0.6032	0.6046	0.6060	0.6074	0.6088	0.6101	0.6115	0.6129	0.6143
	cos	0.7986	0.7976	0.7965	0.7955	0.7944	0.7934	0.7923	0.7912	0.7902	0.7891
	tan	0.7536	0.7563	0.7590	0.7618	0.7646	0.7673	0.7701	0.7729	0.7757	0.7785
38	sin	0.6157	0.6170	0.6184	0.6198	0.6211	0.6225	0.6239	0.6252	0.6266	0.6280
	cos	0.7880	0.7869	0.7859	0.7848	0.7837	0.7826	0.7815	0.7804	0.7793	0.7782
	tan	0.7813	0.7841	0.7869	0.7898	0.7926	0.7954	0.7983	0.8012	0.8040	0.8069
39	sin	0.6293	0.6307	0.6320	0.6334	0.6347	0.6361	0.6374	0.6388	0.6401	0.6414
	cos	0.7771	0.7760	0.7749	0.7738	0.7727	0.7716	0.7705	0.7694	0.7683	0.7672
	tan	0.8098	0.8127	0.8156	0.8185	0.8214	0.8243	0.8273	0.8302	0.8332	0.8361
40	sin	0.6428	0.6441	0.6455	0.6468	0.6481	0.6494	0.6508	0.6521	0.6534	0.6547
	cos	0.7660	0.7649	0.7638	0.7627	0.7615	0.7604	0.7593	0.7581	0.7570	0.7559
	tan	0.8391	0.8421	0.8451	0.8481	0.8511	0.8541	0.8571	0.8601	0.8632	0.8662
41	sin	0.6561	0.6574	0.6587	0.6600	0.6613	0.6626	0.6639	0.6652	0.6665	0.6678
	cos	0.7547	0.7536	0.7524	0.7513	0.7501	0.7490	0.7478	0.7466	0.7455	0.7443
	tan	0.8693	0.8724	0.8754	0.8785	0.8816	0.8847	0.8878	0.8910	0.8941	0.8972
42	sin	0.6691	0.6704	0.6717	0.6730	0.6743	0.6756	0.6769	0.6782	0.6794	0.6807
	cos	0.7431	0.7420	0.7408	0.7396	0.7385	0.7373	0.7361	0.7349	0.7337	0.7325
	tan	0.9004	0.9036	0.9067	0.9099	0.9131	0.9163	0.9195	0.9228	0.9260	0.9293
43	sin	0.6820	0.6833	0.6845	0.6858	0.6871	0.6884	0.6896	0.6909	0.6921	0.6934
	cos	0.7314	0.7302	0.7290	0.7278	0.7266	0.7254	0.7242	0.7230	0.7218	0.7206
	tan	0.9325	0.9358	0.9391	0.9424	0.9457	0.9490	0.9523	0.9556	0.9590	0.9623
44	sin	0.6947	0.6959	0.6972	0.6984	0.6997	0.7009	0.7022	0.7034	0.7046	0.7059
	cos	0.7193	0.7181	0.7169	0.7157	0.7145	0.7133	0.7120	0.7108	0.7096	0.7083
	tan	0.9657	0.9691	0.9725	0.9759	0.9793	0.9827	0.9861	0.9896	0.9930	0.9965
Degs.	Function	0'	6'	12'	18'	24'	30'	36'	42'	48'	54'

Natural Sines, Cosines, and Tangents—(Continued)
45°-59.9°

Degs.	Function	0.0°	0.1°	0.2°	0.3°	0.4°	0.5°	0.6°	0.7°	0.8°	0.9°
45	sin	0.7071	0.7083	0.7096	0.7108	0.7120	0.7133	0.7145	0.7157	0.7169	0.7181
	cos	0.7071	0.7059	0.7046	0.7034	0.7022	0.7009	0.6997	0.6984	0.6972	0.6959
	tan	1.0000	1.0035	1.0070	1.0105	1.0141	1.0176	1.0212	1.0247	1.0283	1.0319
46	sin	0.7193	0.7206	0.7218	0.7230	0.7242	0.7254	0.7266	0.7278	0.7290	0.7302
	cos	0.6947	0.6934	0.6921	0.6909	0.6896	0.6884	0.6871	0.6858	0.6845	0.6833
	tan	1.0355	1.0392	1.0428	1.0464	1.0501	1.0538	1.0575	1.0612	1.0649	1.0686
47	sin	0.7314	0.7325	0.7337	0.7349	0.7361	0.7373	0.7385	0.7396	0.7408	0.7420
	cos	0.6820	0.6807	0.6794	0.6782	0.6769	0.6756	0.6743	0.6730	0.6717	0.6704
	tan	1.0724	1.0761	1.0799	1.0837	1.0875	1.0913	1.0951	1.0990	1.1028	1.1067
48	sin	0.7431	0.7443	0.7455	0.7466	0.7478	0.7490	0.7501	0.7513	0.7524	0.7536
	cos	0.6691	0.6678	0.6665	0.6652	0.6639	0.6626	0.6613	0.6600	0.6587	0.6574
	tan	1.1106	1.1145	1.1184	1.1224	1.1263	1.1303	1.1343	1.1383	1.1423	1.1463
49	sin	0.7547	0.7559	0.7570	0.7581	0.7593	0.7604	0.7615	0.7627	0.7638	0.7649
	cos	0.6561	0.6547	0.6534	0.6521	0.6508	0.6494	0.6481	0.6468	0.6455	0.6441
	tan	1.1504	1.1544	1.1585	1.1626	1.1667	1.1708	1.1750	1.1792	1.1833	1.1875
50	sin	0.7660	0.7672	0.7683	0.7694	0.7705	0.7716	0.7727	0.7738	0.7749	0.7760
	cos	0.6428	0.6414	0.6401	0.6388	0.6374	0.6361	0.6347	0.6334	0.6320	0.6307
	tan	1.1918	1.1960	1.2002	1.2045	1.2088	1.2131	1.2174	1.2218	1.2261	1.2305
51	sin	0.7771	0.7782	0.7793	0.7804	0.7815	0.7826	0.7837	0.7848	0.7859	0.7869
	cos	0.6293	0.6280	0.6266	0.6252	0.6239	0.6225	0.6211	0.6198	0.6184	0.6170
	tan	1.2349	1.2393	1.2437	1.2482	1.2527	1.2572	1.2617	1.2662	1.2708	1.2753
52	sin	0.7880	0.7891	0.7902	0.7912	0.7923	0.7934	0.7944	0.7955	0.7965	0.7976
	cos	0.6157	0.6143	0.6129	0.6115	0.6101	0.6088	0.6074	0.6060	0.6046	0.6032
	tan	1.2799	1.2846	1.2892	1.2938	1.2985	1.3032	1.3079	1.3127	1.3175	1.3222
53	sin	0.7986	0.7997	0.8007	0.8018	0.8028	0.8039	0.8049	0.8059	0.8070	0.8080
	cos	0.6018	0.6004	0.5990	0.5976	0.5962	0.5948	0.5934	0.5920	0.5906	0.5892
	tan	1.3270	1.3319	1.3367	1.3416	1.3465	1.3514	1.3564	1.3613	1.3663	1.3713
54	sin	0.8090	0.8100	0.8111	0.8121	0.8131	0.8141	0.8151	0.8161	0.8171	0.8181
	cos	0.5878	0.5864	0.5850	0.5835	0.5821	0.5807	0.5793	0.5779	0.5764	0.5750
	tan	1.3764	1.3814	1.3865	1.3916	1.3968	1.4019	1.4071	1.4124	1.4176	1.4229
55	sin	0.8192	0.8202	0.8211	0.8221	0.8231	0.8241	0.8251	0.8261	0.8271	0.8281
	cos	0.5736	0.5721	0.5707	0.5693	0.5678	0.5664	0.5650	0.5635	0.5621	0.5606
	tan	1.4281	1.4335	1.4388	1.4442	1.4496	1.4550	1.4605	1.4659	1.4715	1.4770
56	sin	0.8290	0.8300	0.8310	0.8320	0.8329	0.8339	0.8348	0.8358	0.8368	0.8377
	cos	0.5592	0.5577	0.5563	0.5548	0.5534	0.5519	0.5505	0.5490	0.5476	0.5461
	tan	1.4826	1.4882	1.4938	1.4994	1.5051	1.5108	1.5166	1.5224	1.5282	1.5340
57	sin	0.8387	0.8396	0.8406	0.8415	0.8425	0.8434	0.8443	0.8453	0.8462	0.8471
	cos	0.5446	0.5432	0.5417	0.5402	0.5388	0.5373	0.5358	0.5344	0.5329	0.5314
	tan	1.5399	1.5458	1.5517	1.5577	1.5637	1.5697	1.5757	1.5818	1.5880	1.5941
58	sin	0.8480	0.8490	0.8499	0.8508	0.8517	0.8526	0.8536	0.8545	0.8554	0.8563
	cos	0.5299	0.5284	0.5270	0.5255	0.5240	0.5225	0.5210	0.5195	0.5180	0.5165
	tan	1.6003	1.6066	1.6128	1.6191	1.6255	1.6319	1.6383	1.6447	1.6512	1.6577
59	sin	0.8572	0.8581	0.8590	0.8599	0.8607	0.8616	0.8625	0.8634	0.8643	0.8652
	cos	0.5150	0.5135	0.5120	0.5105	0.5090	0.5075	0.5060	0.5045	0.5030	0.5015
	tan	1.6643	1.6709	1.6775	1.6842	1.6909	1.6977	1.7045	1.7113	1.7182	1.7251
Degs.	Function	0'	6'	12'	18'	24'	30'	36'	42'	48'	54'

Natural Sines, Cosines, and Tangents—(Continued)

60°-74.9°

Degs.	Function	0.0°	0.1°	0.2°	0.3°	0.4°	0.5°	0.6°	0.7°	0.8°	0.9°
60	sin	0.8660	0.8669	0.8678	0.8686	0.8695	0.8704	0.8712	0.8721	0.8729	0.8738
	cos	0.5000	0.4985	0.4970	0.4955	0.4939	0.4924	0.4909	0.4894	0.4879	0.4863
	tan	1.7321	1.7391	1.7461	1.7532	1.7603	1.7675	1.7747	1.7820	1.7893	1.7966
61	sin	0.8746	0.8755	0.8763	0.8771	0.8780	0.8788	0.8796	0.8805	0.8813	0.8821
	cos	0.4848	0.4833	0.4818	0.4802	0.4787	0.4772	0.4756	0.4741	0.4726	0.4710
	tan	1.8040	1.8115	1.8190	1.8265	1.8341	1.8418	1.8495	1.8572	1.8650	1.8728
62	sin	0.8829	0.8838	0.8846	0.8854	0.8862	0.8870	0.8878	0.8886	0.8894	0.8902
	cos	0.4695	0.4679	0.4664	0.4648	0.4633	0.4617	0.4602	0.4586	0.4571	0.4555
	tan	1.8807	1.8887	1.8967	1.9047	1.9128	1.9210	1.9292	1.9375	1.9458	1.9542
63	sin	0.8910	0.8918	0.8926	0.8934	0.8942	0.8949	0.8957	0.8965	0.8973	0.8980
	cos	0.4540	0.4524	0.4509	0.4493	0.4478	0.4462	0.4446	0.4431	0.4415	0.4399
	tan	1.9626	1.9711	1.9797	1.9883	1.9970	2.0057	2.0145	2.0233	2.0323	2.0413
64	sin	0.8988	0.8996	0.9003	0.9011	0.9018	0.9026	0.9033	0.9041	0.9048	0.9056
	cos	0.4384	0.4368	0.4352	0.4337	0.4321	0.4305	0.4289	0.4274	0.4258	0.4242
	tan	2.0503	2.0594	2.0686	2.0778	2.0872	2.0965	2.1060	2.1155	2.1251	2.1348
65	sin	0.9063	0.9070	0.9078	0.9085	0.9092	0.9100	0.9107	0.9114	0.9121	0.9128
	cos	0.4226	0.4210	0.4195	0.4179	0.4163	0.4147	0.4131	0.4115	0.4099	0.4083
	tan	2.1445	2.1543	2.1642	2.1742	2.1842	2.1943	2.2045	2.2148	2.2251	2.2355
66	sin	0.9135	0.9143	0.9150	0.9157	0.9164	0.9171	0.9178	0.9184	0.9191	0.9198
	cos	0.4067	0.4051	0.4035	0.4019	0.4003	0.3987	0.3971	0.3955	0.3939	0.3923
	tan	2.2460	2.2566	2.2673	2.2781	2.2889	2.2998	2.3109	2.3220	2.3332	2.3445
67	sin	0.9205	0.9212	0.9219	0.9225	0.9232	0.9239	0.9245	0.9252	0.9259	0.9265
	cos	0.3907	0.3891	0.3875	0.3859	0.3843	0.3827	0.3811	0.3795	0.3778	0.3762
	tan	2.3559	2.3673	2.3789	2.3906	2.4023	2.4142	2.4262	2.4383	2.4504	2.4627
68	sin	0.9272	0.9278	0.9285	0.9291	0.9298	0.9304	0.9311	0.9317	0.9323	0.9330
	cos	0.3746	0.3730	0.3714	0.3697	0.3681	0.3665	0.3649	0.3633	0.3616	0.3600
	tan	2.4751	2.4876	2.5002	2.5129	2.5257	2.5386	2.5517	2.5649	2.5782	2.5916
69	sin	0.9336	0.9342	0.9348	0.9354	0.9361	0.9367	0.9373	0.9379	0.9385	0.9391
	cos	0.3584	0.3567	0.3551	0.3535	0.3518	0.3502	0.3486	0.3469	0.3453	0.3437
	tan	2.6051	2.6187	2.6325	2.6464	2.6605	2.6746	2.6889	2.7034	2.7179	2.7326
70	sin	0.9397	0.9403	0.9409	0.9415	0.9421	0.9426	0.9432	0.9438	0.9444	0.9449
	cos	0.3420	0.3404	0.3387	0.3371	0.3355	0.3338	0.3322	0.3305	0.3289	0.3272
	tan	2.7475	2.7625	2.7776	2.7929	2.8083	2.8239	2.8397	2.8556	2.8716	2.8878
71	sin	0.9455	0.9461	0.9466	0.9472	0.9478	0.9483	0.9489	0.9494	0.9500	0.9505
	cos	0.3256	0.3239	0.3223	0.3206	0.3190	0.3173	0.3156	0.3140	0.3123	0.3107
	tan	2.9042	2.9208	2.9375	2.9544	2.9714	2.9887	3.0061	3.0237	3.0415	3.0595
72	sin	0.9511	0.9516	0.9521	0.9527	0.9532	0.9537	0.9542	0.9548	0.9553	0.9558
	cos	0.3090	0.3074	0.3057	0.3040	0.3024	0.3007	0.2990	0.2974	0.2957	0.2940
	tan	3.0777	3.0961	3.1146	3.1334	3.1524	3.1716	3.1910	3.2106	3.2305	3.2506
73	sin	0.9563	0.9568	0.9573	0.9578	0.9583	0.9588	0.9593	0.9598	0.9603	0.9608
	cos	0.2924	0.2907	0.2890	0.2874	0.2857	0.2840	0.2823	0.2807	0.2790	0.2773
	tan	3.2709	3.2914	3.3122	3.3332	3.3544	3.3759	3.3977	3.4197	3.4420	3.4646
74	sin	0.9613	0.9617	0.9622	0.9627	0.9632	0.9636	0.9641	0.9646	0.9650	0.9655
	cos	0.2756	0.2740	0.2723	0.2706	0.2689	0.2672	0.2656	0.2639	0.2622	0.2605
	tan	3.4874	3.5105	3.5339	3.5576	3.5816	3.6059	3.6305	3.6554	3.6806	3.7062
Degs.	Function	0'	6'	12'	18'	24'	30'	36'	42'	48'	54'

Natural Sines, Cosines, and Tangents—(Continued)

75°-89.9°

Degs.	Function	0.0°	0.1°	0.2°	0.3°	0.4°	0.5°	0.6°	0.7°	0.8°	0.9°
75	sin	0.9659	0.9664	0.9668	0.9673	0.9677	0.9681	0.9686	0.9690	0.9694	0.9699
	cos	0.2588	0.2571	0.2554	0.2538	0.2521	0.2504	0.2487	0.2470	0.2453	0.2436
	tan	3.7321	3.7583	3.7848	3.8118	3.8391	3.8667	3.8947	3.9232	3.9520	3.9812
76	sin	0.9703	0.9707	0.9711	0.9715	0.9720	0.9724	0.9728	0.9732	0.9736	0.9740
	cos	0.2419	0.2402	0.2385	0.2368	0.2351	0.2334	0.2317	0.2300	0.2284	0.2267
	tan	4.0108	4.0408	4.0713	4.1022	4.1335	4.1653	4.1976	4.2303	4.2635	4.2972
77	sin	0.9744	0.9748	0.9751	0.9755	0.9759	0.9763	0.9767	0.9770	0.9774	0.9778
	cos	0.2250	0.2232	0.2215	0.2198	0.2181	0.2164	0.2147	0.2130	0.2113	0.2096
	tan	4.3315	4.3662	4.4015	4.4374	4.4737	4.5107	4.5483	4.5864	4.6252	4.6646
78	sin	0.9781	0.9785	0.9789	0.9792	0.9796	0.9799	0.9803	0.9806	0.9810	0.9813
	cos	0.2079	0.2062	0.2045	0.2028	0.2011	0.1994	0.1977	0.1959	0.1942	0.1925
	tan	4.7046	4.7453	4.7867	4.8288	4.8716	4.9152	4.9594	5.0045	5.0504	5.0970
79	sin	0.9816	0.9820	0.9823	0.9826	0.9829	0.9833	0.9836	0.9839	0.9842	0.9845
	cos	0.1908	0.1891	0.1874	0.1857	0.1840	0.1822	0.1805	0.1788	0.1771	0.1754
	tan	5.1446	5.1929	5.2422	5.2924	5.3435	5.3955	5.4486	5.5026	5.5578	5.6140
80	sin	0.9848	0.9851	0.9854	0.9857	0.9860	0.9863	0.9866	0.9869	0.9871	0.9874
	cos	0.1736	0.1719	0.1702	0.1685	0.1668	0.1650	0.1633	0.1616	0.1599	0.1582
	tan	5.6713	5.7297	5.7894	5.8502	5.9124	5.9758	6.0405	6.1066	6.1742	6.2432
81	sin	0.9877	0.9880	0.9882	0.9885	0.9888	0.9890	0.9893	0.9895	0.9898	0.9900
	cos	0.1564	0.1547	0.1530	0.1513	0.1495	0.1478	0.1461	0.1444	0.1426	0.1409
	tan	6.3138	6.3859	6.4596	6.5350	6.6122	6.6912	6.7720	6.8548	6.9395	7.0264
82	sin	0.9903	0.9905	0.9907	0.9910	0.9912	0.9914	0.9917	0.9919	0.9921	0.9923
	cos	0.1392	0.1374	0.1357	0.1340	0.1323	0.1305	0.1288	0.1271	0.1253	0.1236
	tan	7.1154	7.2066	7.3002	7.3962	7.4947	7.5958	7.6996	7.8062	7.9158	8.0285
83	sin	0.9925	0.9928	0.9930	0.9932	0.9934	0.9936	0.9938	0.9940	0.9942	0.9943
	cos	0.1219	0.1201	0.1184	0.1167	0.1149	0.1132	0.1115	0.1097	0.1080	0.1063
	tan	8.1443	8.2636	8.3863	8.5126	8.6427	8.7769	8.9152	9.0579	9.2052	9.3572
84	sin	0.9945	0.9947	0.9949	0.9951	0.9952	0.9954	0.9956	0.9957	0.9959	0.9960
	cos	0.1045	0.1028	0.1011	0.0993	0.0976	0.0958	0.0941	0.0924	0.0906	0.0889
	tan	9.5144	9.6768	9.8448	10.02	10.20	10.39	10.58	10.78	10.99	11.20
85	sin	0.9962	0.9963	0.9965	0.9966	0.9968	0.9969	0.9971	0.9972	0.9973	0.9974
	cos	0.0872	0.0854	0.0837	0.0819	0.0802	0.0785	0.0767	0.0750	0.0732	0.0715
	tan	11.43	11.66	11.91	12.16	12.43	12.71	13.00	13.30	13.62	13.95
86	sin	0.9976	0.9977	0.9978	0.9979	0.9980	0.9981	0.9982	0.9983	0.9984	0.9985
	cos	0.0698	0.0680	0.0663	0.0645	0.0628	0.0610	0.0593	0.0576	0.0558	0.0541
	tan	14.30	14.67	15.06	15.46	15.89	16.35	16.83	17.34	17.89	18.46
87	sin	0.9986	0.9987	0.9988	0.9989	0.9990	0.9990	0.9991	0.9992	0.9993	0.9993
	cos	0.0523	0.0506	0.0488	0.0471	0.0454	0.0436	0.0419	0.0401	0.0384	0.0366
	tan	19.08	19.74	20.45	21.20	22.02	22.90	23.86	24.90	26.03	27.27
88	sin	0.9994	0.9995	0.9995	0.9996	0.9996	0.9997	0.9997	0.9997	0.9998	0.9998
	cos	0.0349	0.0332	0.0314	0.0297	0.0279	0.0262	0.0244	0.0227	0.0209	0.0192
	tan	28.64	30.14	31.82	33.69	35.80	38.19	40.92	44.07	47.74	52.08
89	sin	0.9998	0.9999	0.9999	0.9999	0.9999	1.000	1.000	1.000	1.000	1.000
	cos	0.0175	0.0157	0.0140	0.0122	0.0105	0.0087	0.0070	0.0052	0.0035	0.0017
	tan	57.29	63.66	71.62	81.85	95.49	114.6	143.2	191.0	286.5	573.0
Degs.	Function	0'	6'	12'	18'	24'	30'	36'	42'	48'	54'

THE ALLIED ELECTRONICS LIBRARY

...Other Useful and Educational Handbooks

Published By

ALLIED RADIO

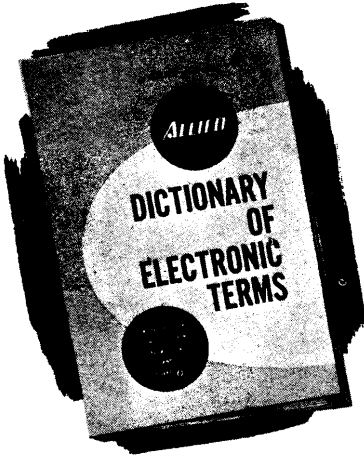

DICTIONARY OF ELECTRONIC TERMS

- More than 3800 Terms Clearly Defined
- Over 125 Illustrations and Diagrams
- Finest Dictionary Value in Electronics

Completely revised, with clear, concise definitions of more than 3800 terms used in Television, Radio, Electronics and Nucleonics. Edited by Robert E. Beam, Ph.D., Professor of Electrical Engineering, Northwestern University. Includes over 125 illustrations and diagrams. Appendix covers the EIA color code, standard schematic symbols, Greek alphabet, letter symbols for Vacuum tubes, and abbreviations and other letter symbols used in electronics. Makes an ideal reference for servicemen, hobbyists, Amateurs, technicians—everyone in the field of electronics. Includes Ohm's Law and basic series-parallel formulas. Also has page on getting started in Amateur radio. 84 pages. Size, 6 x 9".

37 K 756. Postpaid in U.S.A.....50c

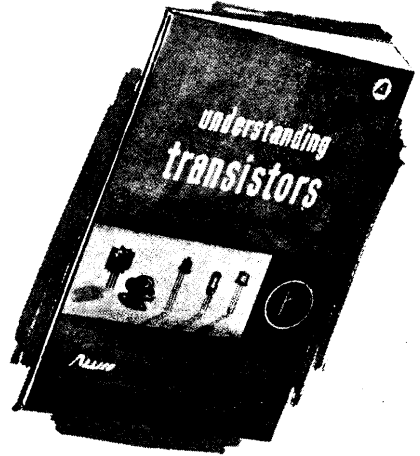

UNDERSTANDING TRANSISTORS And How To Use Them

- Written In Easy-To-Understand Language
- Interesting Construction Projects
- For Electronic Classes or Home Study

A clearly written presentation on transistor applications, characteristics, and construction. Ideal for home study, classroom use, beginners, hobbyists, experimenters, etc. Unexcelled for supplementing a course in electronics, whether the student's interest is primarily in transistors, or electronics in general. Covers NPN, PNP, alloy-junction, drift, tetrode, surface barrier, power types, etc. Contains transistor symbols, diagrams of various amplifier circuits, etc. Includes interesting construction projects using transistors for useful and "fun" devices around the home. Circuit theory as related to transistor operation is discussed in simple terms. 96 pages. Size, 5½ x 8½".

37 K 602. Postpaid in U.S.A.....50c

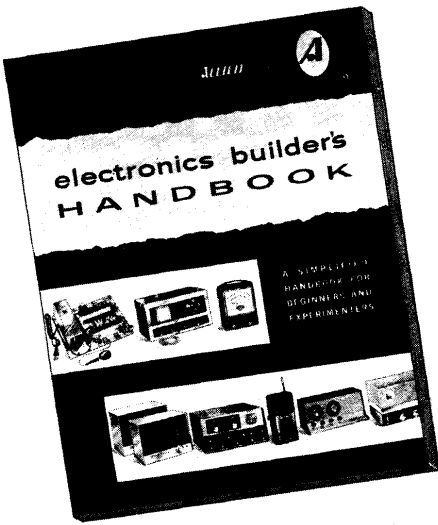

ELECTRONICS BUILDER'S HANDBOOK

An introduction to electronics written in simple language that anyone can understand. Excellent for beginners, and for classroom and home study courses. Clearly explains radio set parts and functions, magnetism, resistance, electron theory, inductance and reactance. Tells how to read schematic diagrams. Covers transistors, high fidelity, printed circuits, Amateur radio, test equipment, antennas, etc. Contains handy list of commonly used symbols and abbreviations. Features interesting construction projects. 56 pages. Size, 8½ x 11".

37 K 750. Postpaid in U.S.A.....35c



BASIC ELECTRONICS HANDBOOK

Written for beginners without any previous electronics experience. Discusses the vacuum tube, rectifiers and power supplies, amplifiers, detectors and radio receivers, oscillators, superhet and electronic control circuits. Includes six fascinating experiments based on the Knight-Kit 12-in-1 Electronic Lab Kit. Numerous diagrams in each chapter for faster, easier learning. Prepared with the classroom in mind, it is ideal for use in elementary science courses. Schools are invited to write for quantity prices. 24 pages. Size, 8½ x 11".

37 K 060. Postpaid in U.S.A.....25c

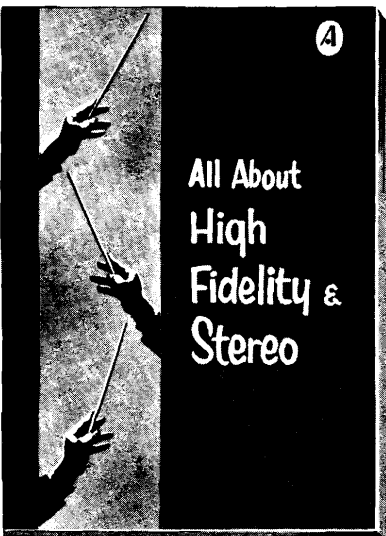

ALL ABOUT HIGH FIDELITY AND STEREO

New, authoritative, easy-to-read handbook on all elements of high fidelity and stereo. Prepared by audio experts under direction of Allied's technical staff to help you understand, select and enjoy your music system. Explains high fidelity and monophonic and stereo sound; covers amplifiers, pre-amplifiers, tuners, speaker systems and enclosures, record players, tone arms, cartridges and needles; tells about monophonic and stereo program sources—records, tape, broadcasts; discusses tape recorders, kits, use of transistors in hi-fi products; includes valuable data on planning a "built-in" system. With added section on clear definitions of hi-fi terms. Many charts and illustrations. Everything written in non-technical language anyone can understand. 96 pages. 5½ x 8½".

37 K 699. Postpaid in U.S.A.....50c