

THIS INFORMATION IS PROVIDED AS A COURTESY
by
PHILLOKIT.COM

PHILLOKIT.COM IS NOT RESPONSIBLE FOR ANY ERRORS OR OMISSIONS

HICKOK

LEADER IN DEPENDABILITY SINCE 1910

INSTRUCTION MANUAL

for

MODEL 800A

**DYNAMIC MUTUAL CONDUCTANCE
TUBE TESTER**

OPERATING INSTRUCTIONS
FOR
DYNAMIC MUTUAL CONDUCTANCE TUBE TESTER
MODEL 800A

Instruction for operation of Model 800A.

Read these instructions through before attempting to operate the Tester.

1. This instrument is designed to operate on 50 to 60 cycles 110-125 volt power source.
2. There are two rectifier tubes, an 83 and a 5Y3GT, necessary to operate this tester. They are included. The line fuse lamp is a standard #81 auto lamp. The bias fuse is a standard 49 lamp.
3. Line Voltage Adjustment:

Turn the power on by rotating the LINE ADJUST knob clockwise from its OFF position. Holding down button P7 will cause the meter pointer to move up scale. The button is held down while the LINE ADJUST knob is turned until the meter pointer rests exactly over the LINE TEST mark at the center of meter scale. This establishes standard voltages on the tube. Make final line adjustment after the tube being tested is placed in its socket.

4. SELECTORS - The row of selector knobs across the center of the control panel is for the purpose of conducting proper voltages to the tube's base pins. The operation of setting these selector knobs is similar to dialing a telephone number. On the roll chart, below the word SELECTORS appear the dialing numbers. These dialing numbers consist of two letters and five figures. Example: JR-6237-5. Starting at the left, the first knob (FIL) is turned until it points to the letter J, the second knob (FIL) is turned to R, the third knob (GRID) to 6, the fourth (PLATE) to 2, the fifth (SCREEN) to 3, the sixth (CATHODE) to 7, and the seventh (SUPPRESSOR) to 5.

The selector system is designed to minimize selector settings. For example, the filament setting is nearly always JR. These two knobs seldom need resetting. Also in testing duo-diode-triode tubes the amount of selector setting has been reduced to a minimum.

5. **LEAKAGE OR SHORTS** - Before making a quality check on a tube under test a **LEAKAGE CHECK** must be made. This is accomplished by rotating the leakage switch, located in the lower right hand corner of the panel, from **TUBE TEST** through its five positions and back to **TUBE TEST** position, while tapping the tube and watching the meter for leakage indications. The meter will indicate leakage in ohms up to 10 megohms on the leakage scale which is just below the **REPLACE-GOOD SCALE**.

Note

When making a **SHORT** test, be sure that the **SELECTOR** switches are not in the same position. If two or more switches are in the same position, a false short will result.

An asterisk * near the 200,000 ohm mark on the leakage scale, indicates the approximate value where a lamp in a conventional neon lamp short test would glow. Tubes showing leakage to the right of this mark should be discarded without further test, unless specified otherwise, in notations column. By using the meter to indicate leakage a more accurate check is provided. This is helpful in selecting tubes, especially those with high heater to cathode leakage (Position No. 1) for special applications.

With tubes having more than one section such as the 12AV6, make a leakage check for each section.

LOCATING LEAKAGE BETWEEN ELEMENTS. In the following table (X) under any leakage switch position, indicates leakage between elements shown.

Kind of Short	1	2	3	4	5
Htr-Cath	X				
Htr-Grid		X			
Htr-Scrn		X	X		
Htr-Plt		X	X	X	
Htr-Sup		X	X	X	X
Cath-Grid	X	X			
Cath-Scrn	X	X	X		
Cath-Plt	X	X	X	X	
Grid-Scrn			X		
Grid-Plt			X	X	
Grid-Sup			X	X	X
Scrn-Plt				X	
Scrn-Sup				X	X

6. **MUTUAL CONDUCTANCE** - If the tube passes the preliminary leakage test it is then tested for **MUTUAL CONDUCTANCE** which is the best test for amplifier tubes. Turn the leakage switch to **TUBE TEST** position. On the roller chart, reading from left to right, opposite the tube type appear: **FIL. VOLTAGE**; **SELECTORS**, which were explained in paragraph (4) above; **BIAS**, which gives the setting for the **BIAS** dial; **SHUNT**, which gives the setting for the **SHUNT** dial; **PRESS**, which indicates the pushbutton to be pressed for meter reading; **MUT-**

COND. which gives the AVERAGE MUTUAL CONDUCTANCE in MICROMHOS of the tube being tested. Under the heading NOTATIONS appear special notes pertaining to the testing of the tube. The SHUNT setting is used when it is desired to read the value of the tube on the RED-GREEN (GOOD & REPLACE) sector of the meter scale. When using the SHUNT scale the MICROMHO readings are disregarded.

NOTE

Tubes having less than 500 Micromhos cannot be made to read in the GREEN sector of the meter scale. Such tubes list micromho reading only and are good if the reading is above a specified minimum.

Micromhos are indicated in three ranges 0-3000, 0-6000, 0-15,000.

- a. On the SHUNT dial are three dots stamped into the metal and filled with red lacquer. These dots are the points used in setting the micromho ranges.
- b. The dot near 73 on the dial is the setting point for the 3000 micromho scale.
- c. The dot near 86 is the point for the 6000 micromho scale.
- d. The dot near 92 is the point for the 15,000 micromho scale.
- e. When reading micromhos the RED and GREEN sectors of the meter scale are disregarded.
- f. When testing for mutual conductance the push switch P4--Gm is pressed. Gm is the symbol for mutual conductance.

CAUTION: Do not press P4 when testing rectifier tubes.

g. Tubes having more than one section, such as the 6J6, require different dial settings for each section.

7. RECTIFIER TUBE TEST - Rectifier tubes, including diode tubes and diode sections of multiple element tubes, having no mutual conductance are tested for emission only.

a. The push switch P1 is used when testing detector diodes. It applies a low voltage which will not injure the delicate cathode. Good diodes will cause the pointer of the meter to move above the point marked DIODES OK.

b. The push switch P2 is used when testing cold cathode rectifiers such as the OZ4. This applies a voltage sufficiently high to ionize the tube and start conduction. Good tubes will read in the green (GOOD) sector of the meter scale.

c. The push switch P3 is used when testing ordinary rectifier tubes, such as the 5Y3. This applies a medium voltage which is best adapted to reveal defects in this type of tube. Good tubes will read in the green (GOOD) sector of the meter scale.

NOTE

On the data chart a star (*) following P1, P2, P3, and P5 indicates that the SHUNT setting only is used.

8. GAS TEST - The push switches P5 and P6 are used to test an amplifier tube for gas content.

a. Set the SHUNT dial at 73.

b. The push switch P5 is pressed and held down while the BIAS dial is turned to cause the pointer of the meter to indicate 100 micromhos on the 0-3000 scale.

c. Hold down P5 and press P6.

d. If the tube contains gas the pointer of the meter will move UP the scale. If the pointer movement is not more than one division of the scale the gas content is satisfactory.

NOTE

With some tubes, such as the type 45, the micro-mhos reading cannot be brought down to 100 by turning the BIAS dial. In such case turn the BIAS dial to 100 and test for gas.

e. Some tubes develop gas after being heated for a period of time. If a tube is suspected, allow it to heat for a few minutes.

9. METER REVERSE - With certain tubes, such as the 117N7, the meter will deflect backwards (to the left) when push switch P3 is pressed for rectifier test. In such a case push P6 also. This will cause the pointer of the meter to move up the scale.

10. TOP CAPS - There are two jacks in the upper center of the control panel marked GRID and PLATE. These are used when making connection to the top cap of the tube being tested. On the data chart in the NOTATIONS column opposite tube types having top caps is the notation CAP=G or CAP=P. G means that the top cap is connected to GRID jack and P that it is connected to the PLATE jack.

11. SOCKET NUMBERING - In order to reduce selector set-up to a minimum, the socket contacts are numbered as shown on Plate 1 which shows the bottom

views. The numerical values of the lettered switch positions are as follows:

SOCKET CONTACTS	FIL.	FIL.	GRID	PLATE	SCRN.	CATH.	SUPP.
O	A	P	O	O	O	O	O
1	B	R	1	1	1	1	1
2	C	S	2	2	2	2	2
3	D	T	3	3	3	3	3
4	E	U	4	4	4	4	4
5	F	V	5	5	5	5	5
6	G	W	6	6	6	6	6
7	H	X	7	7	7	7	7
8	J	Y	8	8	8	8	8
9	K	Z	9	9	9	9	9
10	1	1	A	A	A	A	A
11	2	2	B	B	B	B	B
12	3	3	C	C	C	C	C
13	4	4	D	D	D	D	D

The letter I was omitted because of its resemblance to the number 1. The letter Q was omitted because of its resemblance to the letter O.

SOCKET NUMBERING

BOTTOM VIEWS

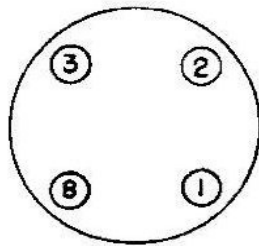

4 PIN

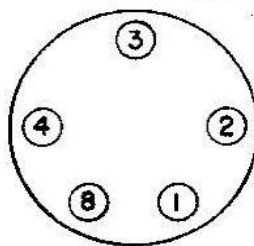

5 PIN

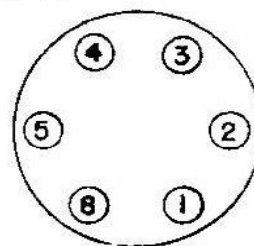

6 PIN

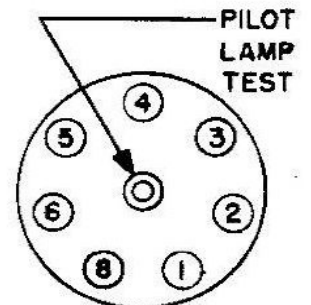

7 PIN STANDARD

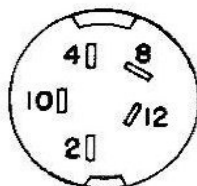

5 PIN
NUVISTOR

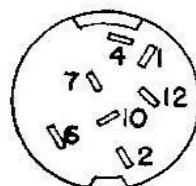

7 PIN
NUVISTOR

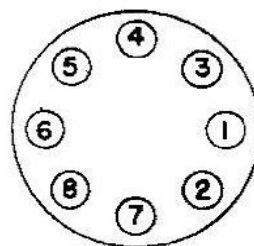

OCTAL

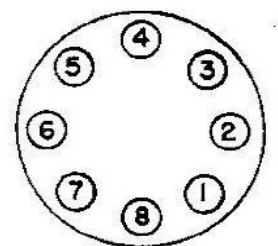

LOCTAL

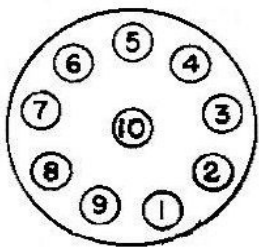

9-10 PIN
MINIATURE

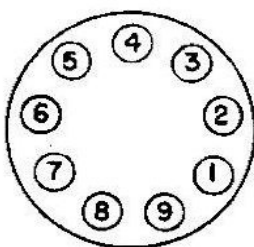

NOVAR

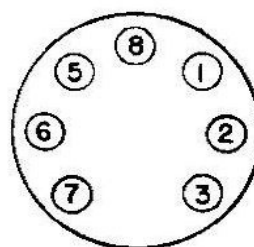

7 PIN
MINIATURE

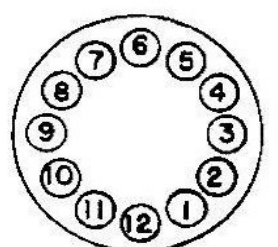

COMPACTRON

NOTE

The center of the large 7-pin socket is used to check pilot lamps. Set the filament selector switches on JR. Set the filament voltage switch to the proper voltage for the lamp being tested.

12. SPECIAL NOTES - Power line voltage varies with different localities. It may also vary with different hours of the day.

While a national survey indicates that the average voltage for the USA is about 117 volts, it does not mean that every locality maintains a constant voltage at that level.

Occasionally we have had the complaint that a used tube will test GOOD, but will not work in the radio receiver; but when a NEW tube is substituted, the receiver will operate correctly. The answer is this: Tubes are built to specifications. Our tube testers are designed to test tubes in conformity with these specifications.

The used tube that would not perform in a certain receiver was not receiving its specified filament voltage. The new tube performed because of its initial reserve capacity. The used tube would have performed if it had received its specified filament voltage.

Tube failure frequently occurs in A. C.--D. C. sets where several tubes are connected with their heaters or filaments in series. Sometimes, even though the power line voltage is normal, a series tube with abnormally high filament resistance will rob its companion tube of its normal filament voltage. The robbed tube apparently fails; but when tested under specified conditions, the tube will test GOOD.

13. The versatility of the Hickok Dynamic Mutual Conductance Tube Tester makes possible a special test that will reveal a tube's ability to perform under adverse conditions as mentioned above. This is possible because the tester measures mutual conductance instead of emission.

THE TEST

- a. Measure the mutual conductance in the ordinary way.
- b. Press P4 and adjust the SHUNT dial until the tube reads in the GREEN (GOOD) sector at 2000 on the 0-3000 scale.
- c. While holding everything else constant, reduce the FILAMENT voltage and note the new reading.
- d. If the meter still reads in the GREEN (GOOD) sector, the tube has a large life reserve and will perform satisfactorily.
- e. The filament voltage reductions to be made are shown in the following table:

NORMAL FIL. VOLTS	REDUCE TO
1.5	1.1
2.0	1.5
2.5	2.0
3.0	2.5
5.0	4.3
6.3	5.0
7.5	6.3
10.0	7.5
12.6	10.0
35.0	25.0
50.0	35.0

14. **CONTINUITY TEST** - The Model 800A Tube Tester can be used to test for continuity through resistances up to more than 10 megs.

- a. Set SHORTS switch on position 4.
- b. Connect two leads having prods and pin tips to the jacks marked PLATE and GRID.
- c. Touch the prods to the terminals through which continuity is to be determined.
- d. The meter will indicate continuity.

15. **FILAMENT AND HEATER CONTINUITY**

1. Turn tester on.
2. Set selectors as per chart for tube to be tested.
3. Set LEAKAGE switch on position 5.
4. Set FILAMENT switch on BLST instead of voltage indicated on chart.
5. Place tube in proper socket.

If the meter reads, the filament is good and a complete test should then be made on the tube, by setting FILAMENT switch on the proper tap, and while the tube heats, rotate the LEAKAGE switch several times thru all positions. If leakage is satisfactory, set the switch in TUBE TEST position and proceed to test the tube as per chart.

If the meter does not read, filament is open and further test is unnecessary. Certain tubes such as the 35Z5-50Z7, etc. with tapped filaments have special continuity test settings, see roll chart:

SERIES STRING HEATER CONTINUITY

On the 800A it is possible to make a fast check of filament continuity on a complete set of tubes from a radio or T.V. set without resetting the selector switches.

For tubes with filament or heaters on 7 & 8, 4 & 5, 3 & 4, 2 & 7, 1 & 8*, 1 & 7, set the SELECTORS on BS 34578; set the FILAMENT switch on BLST; and the LEAKAGE switch on Position 4. Turn tester on and adjust to line test. (These switch positions are marked in red).

Lightly insert each tube in tester socket just far enough for pins to make contact with socket contacts--it is not necessary to push tubes completely into socket. If the filament is not open the meter will move up scale indicating filament continuity.

*For battery type tubes with filament on 1&7 set LEAKAGE switch on position 2.

TO TEST BALLAST TUBES

1. Turn Tester on.
2. Set filament switch to BLST.
3. Set SHORT TEST switch on 5.
4. Set first selector switch (lettered A to K) to letter shown in column marked (first selector) -- Set all numbered selectors on zero.
5. ROTATE second selector switch (lettered P to Z) from P to Z. METER SHOULD INDICATE CONTINUITY IN POSITIONS NOTED.

TUBE TYPE	First Selector	Neon lamp should light in these positions					
1A1-1B1-1C1-1E1-1F1-1G1-1J1-1K1-1L1-1N1-1P1-1Q1-1R1G-1S1G-1T1G-1U1G-1V1-1Y1-1Z1-2	J	R					
2UR224	J			T			X
2LR212	H	R	S		U		
3	J	R					
03G	J			T			
4-5	J	R					
6-133	J			T			
6-6AA	J	R					

TUBE TYPE	First Selector	Neon lamp should light in these positions					
		R	S	T	U	V	X
7-8-9	J	R					
10-10AG	J			T			
10AB	J			T			X
K17B-M17C-BM17C	J			T			X
M17HG-M17H	J		S				X
	D	R					
K23B-K23C-KX23B-KX30C	J			T			X
M30H	J		S				X
	D	R					
30A-K30A	J			T			
K30D	J	R		T			X
33A-33AG	J			T			
K34B	J			T			X
36A	J			T			
K36B-BK36B-L36B-BM-L36C-KX36C	J			T			X
KX36A	J	R					
36D-L36D	J	R		T			X
L36DJ	J	R	S	T	U		X
K36H-M36H-M36HG	J		S				X
	D	R					
L40S1-L40S2	J	R		T		V	
42A	J			T			
42A1	H				U		
42A2-42B2	H		S		U		
K42B-L42B-M42B-KX42B-LX42B-L42BX-K42C L42C-M42C	J			T			X
KB42D-K42D-L42D	J	R		T			X

TUBE TYPE	First Selector	Neon lamp should light in these positions					
		R	S	T			
LX42D-L42DX	J	R	S	T			
K42E-L42E	J			T			X
L42F	J						X
	D	R					
42HA-K42HJ-M42H-M42HG	J		S				X
	E	R		T			
KX42C	J			T			X
L42S1	J	R		T		V	
49A-49AJ-K49AJ	J			T			
KX49A	J			T			X
49A1	H					U	
49A2-49B2	H		S			U	
K49B-L49B-M49B-BM49B-K49C-M49C-BM49C-BK49C-K49E-L49E	J			T			X
K49D-BK49D-L49D	J			T			X
	J						X
L49F	D	R					
	J		S				X
M49H-M49HG	D	R					
KZ49B-KZ49C	J	R				V	
K49BJ-L49BJ	J			T	U		X
L49S2	J	R		T		V	
49AJ-K49AJ	J			T			
KX49B-LX49B-LX49C	J			T			X
L49DJ	J	R		T	U		X
L49S3	J	R		T		V	
50A2	J	R		T			
50A2MG-50B2	J	R				V	

TUBE TYPE	First Selector	Neon lamp should light in these positions					
50X3	J	R					
K52H-M52H	J		S				X
	D	R					
K54B	J			T			X
55A-K55A	J			T			
55A1	H				U		
KX55A	J	R					
55B-K55B-M55B-BM55B-L55BG-LX55B	J			T			X
55A2-55B2	H		S		U		
K55C-L55C-KX55C	J			T			X
K55CP	J			T		V	X
K55D-L55D	J	R		T			X
L55E-M55E	J			T			X
L55F-M55F-BL55F	J						X
	D	R					
K55H-M55H-M55HG	J		S				X
	D	R					
L55S1-L55S2	J	R		T		V	X
60R30G	J	R		T			
64.23	J			T			
67A	J			T			
K67B-L67B	J			T			X
L73B-K74B-L74B-CX74C	J			T			X
80A	J			T			
K79B-K80B-M80B-K80C-KX80B-L80B	J			T			X
K80F	J						X
	D	R					

TUBE TYPE	First Selector	Neon lamp should light in these positions					
KX87B-LX87B-L90B	J			T			X
K90F-M90F-K92F-M92F	J						X
	D	R					
92A	J			T			
L92B-95K2	J			T			X
L99D	J	R		T			X
100R8	J			T			X
120R	J	R					
120RS-135K1	J			T			X
135K1A	J			T	U		X
140L4-140L8-140R4-140R8	J	R		T			
140R	J	R					
140L44-140R44	J	R	S	T			
165L4-165R4-165R8	J	R		T			
165R	J	R					
165L44-165R44	J	R	S	T			
185L4-185L8-185R4-185R8	J	R		T			
185R	J	R					
185L44-185R44	J	R	S	T			
200R-250R	J	R					
250R8-290L4	J			T			X
300R4-320R4	J			T			X
340	J	R					
808-1	J			T	U		X
E14980-W43357-W4588-3613	J			T			X

TUBE TYPE	First Selector	Neon lamp should light in these positions					
3334-3334A	J	R		T			X
8593-8598-8601-8664	J			T			X
3ER248	J	R		T	U		X
3CR241	J	R		T			X

CHECKING TRANSISTORS AND DIODES ON THE MODEL 800 A

Transistors - PNP - NPN

Testing Junction and Point Contact transistors:

Rotate LEAKAGE SWITCH (lower right corner of panel) clockwise from TUBE TEST to TRANSISTOR TEST.

1. Insert the transistor to be checked in the proper socket, PNP or NPN. Consult manufacturer's data to determine the type. Transistors can be damaged if inserted in wrong socket.
2. SHUNT dial is adjusted until meter reads full scale (or to the maximum reading possible if transistor will not cause meter to read full scale). If meter fails to read, transistor is open or defective.
3. Push slide switch from GAIN to LEAKAGE position. Meter will now read leakage current. If reading is in the POOR area, the transistor should be discarded.

Rectifiers - Copper Oxide, Selenium, and Silicon

The red (+) and black (-) jacks, located near the transistor test sockets are used to check the forward to reverse conduction ratio of rectifiers. Rectifiers must be disconnected from its circuit when testing.

1. The positive terminal of the rectifier is connected to the black (-) jack. The negative terminal of the rectifier is connected to the red (+) jack. When connected this way the rectifier is biased in the forward direction.
2. Rotate leakage switch (lower right corner) clockwise from TUBE TEST to TRANSISTOR TEST.
3. Adjust shunt dial for full scale deflection of meter (100%).
4. Connections to rectifier are then reversed, rectifier is then biased in reverse direction. Rectifiers that read 10% or more in reversed direction are probably defective and should be replaced.

Diodes - Silicon and Germanium

1. Diodes are checked by the same procedure as testing rectifiers, because they rectify but do not handle large currents like power rectifiers.

Some knowledge of the characteristics of the diode being tested will help because some high conduction diodes used in video detectors, can be rated good if they produce a 10:1 (10%) forward to reverse conduction ratio.

PARTS LIST FOR MODEL 800A TUBE TESTER

Reference designations are assigned to identify all parts of the Model 800A. These designations are used in the Parts List and Schematic Wiring Diagram. The letter prefix of a reference designation indicates the kind of part -- resistor, capacitor, electron tube, etc. The number differentiates between parts in the same group.

REF. DESIG.	NOTES	NAME AND DESCRIPTION	HICKOK PART NO.
A1		DIAL ASSEMBLY: Bias Control	4160-67
A2		DIAL ASSEMBLY: Shunt Control	4160-73
C1		CAPACITOR, ELECTROLYTIC: 50 μ f, 6 volts	3085-45
C2		CAPACITOR, PLASTIC, TUBULAR: .5 μ f, 200 volts	3105-206
C3		CAPACITOR, CERAMIC: .005 μ f	3110-7
C4		Same as C3	
F1		LAMP: #81, bayonet type	12270-2
F2		LAMP: #49 pilot, .06 amp, 2 volts	12270-17
J1		JACK: pin plug type, red	10300-1
J2		JACK: pin plug type, black	10300-2
J3		Same as J1 PLATE CAP	
J4		Same as J2 GRID CAP	
M1		METER: D. C. , 66K, 500 microamps, 233 ohms	660-114
MP1		KNOB: machined, with white dot, bar type	11505-46
MP2		Same as MP1	
MP3		Same as MP1	
MP4		Same as MP1	
MP5		Same as MP1	
MP6		Same as MP1	
MP7		Same as MP1	
MP8		Same as MP1	
MP9		Same as MP1	
MP10		Same as MP1	
P1		CORD: AC line	3675-7
R1		RHEOSTAT: 150 ohms, 25 watts, with concentric off position (Line Adjust)	18750-27
R2		RESISTOR: 100 ohms, 10%, 10 watt, center tapped	18575-19
R3		Not Assigned	
R4		RESISTOR, FIXED, DEPOSITED FILM: 12 ohms, 1%, 1/2 watt	18537-59
R5		RESISTOR, FIXED, COMPOSITION: 1.2K ohms, 10%, 1 watt	18422-122

REF. DESIG.	NOTES	NAME AND DESCRIPTION	HICKOK PART NO.
R6		RESISTOR, FIXED: 1800 ohms, 10%, 10 watt	18575-12
R7		RESISTOR, FIXED, DEPOSITED FILM: 215K ohms, 1%, 1 watt	18539-32
R8		RESISTOR, FIXED, DEPOSITED FILM: 133 ohms, 1%, 1/2 watt	18537-91
R9		POTENTIOMETER, WIRE WOUND: 150-150 ohms (Shunt Control)	16925-90
R10		Same as R9 (Shunt Control)	
R11		RESISTOR, FIXED, DEPOSITED FILM: 112K ohms, 1%, 1/2 watt	18537-55
R12		RESISTOR, FIXED, COMPOSITION: 47 ohms, 10%, 1/2 watt	18410-472
R13		RESISTOR, FIXED, COMPOSITION: 220K ohms, 10%, 1/2 watt	18414-222
R14		Same as R13	
R15		RESISTOR, WIRE WOUND: 8500 ohms, 10 watt	18575-89
R16		POTENTIOMETER, ADJUSTED: (3K) (Bias Control)	16926-5
R17		RESISTOR, FIXED, COMPOSITION: 180K ohms, 10%, 1/2 watt	18414-182
R18		Same as R12	
R19		RESISTOR, FIXED, COMPOSITION: 680 ohms, 10%, 1/2 watt	18411-682
R20		RESISTOR, FIXED, COMPOSITION: 220 ohms, 10% 1/2 watt	18411-222
R21		RESISTOR, FIXED, COMPOSITION: 15K ohms, 5%, 1 watt	18423-151
R22		RESISTOR, FIXED, DEPOSITED FILM: 200 ohms, 1%, 2 watt	18540-5
S1		SWITCH: Slide D. P. D. T. spring return (Gain - Leakage)	19911-64
S2		SWITCH: Rotary, 1 section, 2 pole, 20 positions (Filament Selector Switch)	19912-202
S3		SWITCH: Push Button, 7 button gang	19910-95
S4		SWITCH: Rotary, 1 section, 14 position (Filament Selector)	19912-477
S5		Same as S4 (Filament Selector)	
S6		Same as S4 (Grid Selector)	
S7		SWITCH: Rotary, 1 section, 14 position (Plate Selector)	19912-469
S8		Same as S7 (Screen Selector)	
S9		Same as S7 (Cathode Selector)	
S10		Same as S7 (Suppressor Selector)	
S11		SWITCH: Rotary, 6 section, 7 position, (Leakage Test)	19912-376

REF. DESIG.	NOTES	NAME AND DESCRIPTION	HICKOK PART NO.
T1		TRANSFORMER: Power	20800-219
V1		TUBE: 83	20875-28
V2		TUBE: 5Y3GT/G	20875-6
XF1		SOCKET: bayonet	19350-1
XF2		SOCKET: miniature, bayonet base	19350-203
XQ1		SOCKET: Transistor	19350-280
XV1		SOCKET: wafer, 4 pin	19350-157
XV2		SOCKET: wafer, octal	19350-156
XV3		SOCKET: 9 pin, Novar	19350-367
XV4		SOCKET: 4 pin, black	19350-93
XV5		SOCKET: 5 pin	19350-94
XV6		SOCKET ASSEMBLY: 5 pin Nuvistor	19350-381
XV7		SOCKET: 6 pin	19350-95
XV8		SOCKET: 7 pin	19350-96
XV9		SOCKET: 8 pin, octal	19350-99
XV10		SOCKET: Loctal, 8 pin	19350-97
XV11		SOCKET: 9/10 pin miniature	19350-364
XV12		SOCKET: 7 pin miniature	19350-136
XV13		SOCKET: 12 pin, Compactron	19350-365
XV14		SOCKET: 7 pin Nuvistor Assembly	19350-382
		BOOKLET: Instructions	2490-392
		CHART: Data Roll	3200-98
<p>NOTE: A minimum billing charge of \$3.50 will be assessed for any parts order. Prices are subject to <u>change</u> without notice.</p>			

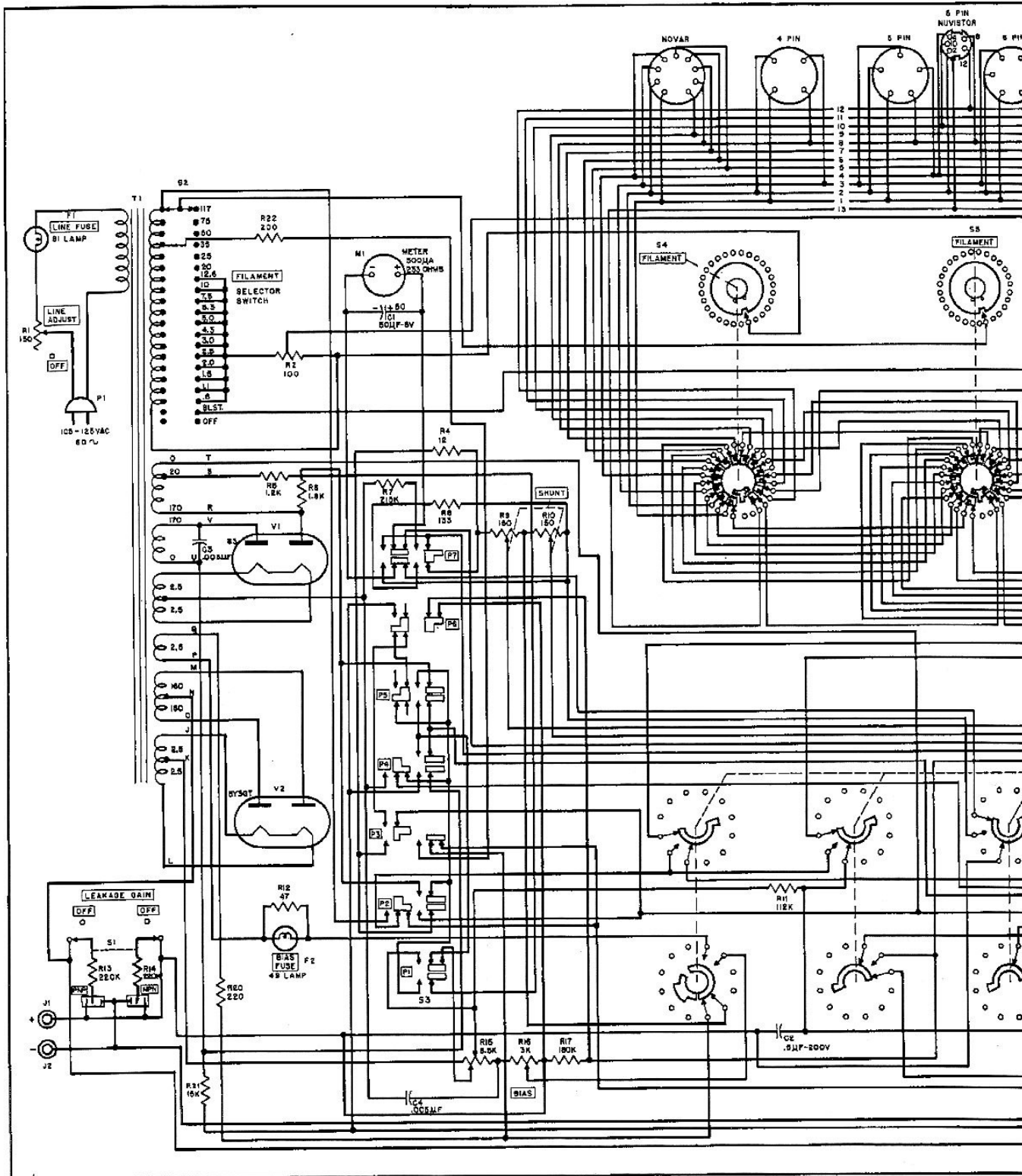

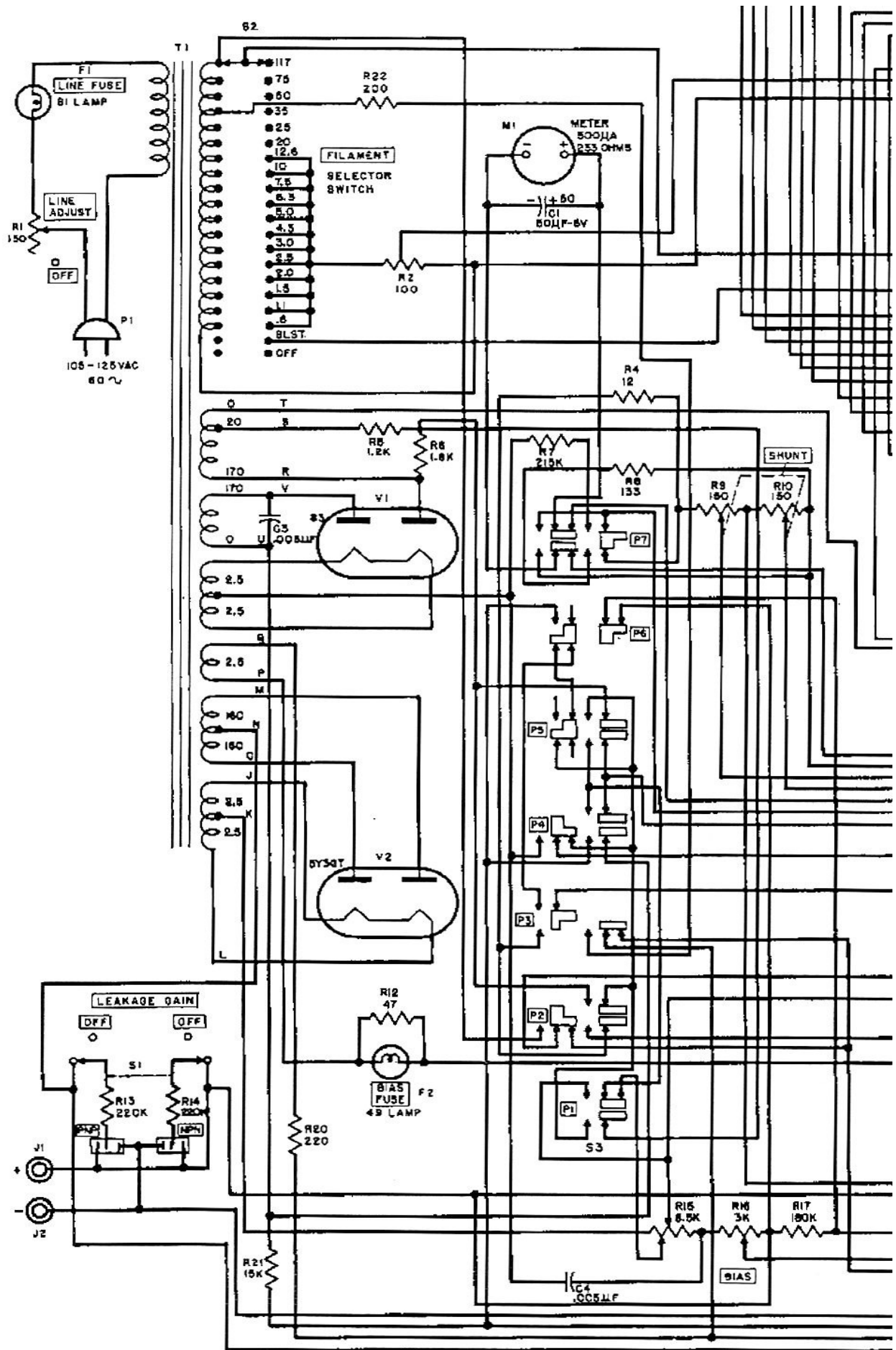

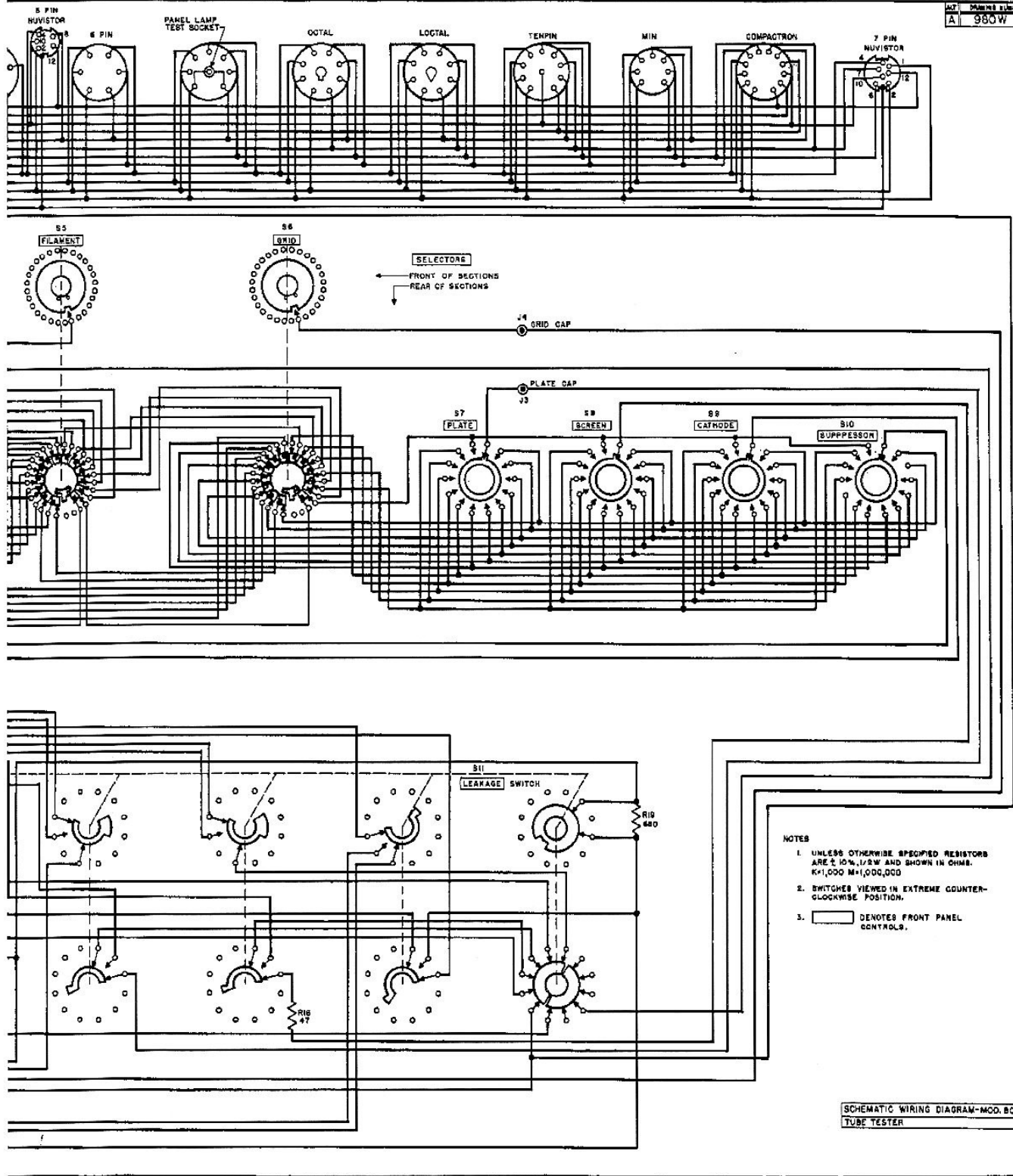

- NOTES
1. UNLESS OTHERWISE SPECIFIED RESISTORS ARE $\pm 10\%$, 1/2W AND SHOWN IN OHMS.
K=1,000 M=1,000,000
 2. SWITCHES VIEWED IN EXTREME COUNTER-CLOCKWISE POSITION.
 3. DENOTES FRONT PANEL CONTROLS.

SCHEMATIC WIRING DIAGRAM-MCO. 8004
TUBE TESTER

NOTE:

A dead Hickok tube tester may be the result of a bad meter. To test the meter, unsolder the leads (do not attempt to unscrew the terminals on the back of the meter). Find a 1.5VDC battery and a 3000 ohm resistor. Connect the negative battery to the negative meter terminal. Connect one end of the 3000 ohm resistor to the battery positive and the other end of the 3000 ohm resistor to the positive meter terminal. The 3000 ohm resistor should be in series with the battery. **DO NOT CONNECT A BATTERY DIRECTLY ACROSS THE METER.**

The meter in the Hickok tube tester is a 500ua (micro-amp) meter. 1 1/2 volts through a 3000 ohm resistor will draw 500ua current and the meter should read full scale.

If the meter does not read, and the meter movement seems to be working freely and not sticking when you gently shake the meter back and forth, there is a good chance the problem is a coil inside the meter has opened up. This meter can be carefully taken apart and fixed if the problem is the coil.

Remove the meter from the tester. Remove the four small screws from the back of the meter window face. Carefully work the window face off the meter, do not force it, work your way around the meter and keep nudging until it comes loose. Hold the meter face up as you lift the meter window up and off the meter.

Remove the four screws holding the meter face. Carefully slide the meter face to the top left and allow the needle to slide out. There are two needle limit springs located left and right of the meter movement that prevent the needle from pegging into the side of the meter window. Take good note of how they are positioned, then carefully lift them off and set to the side.

The coil in question is located just above the meter movement. The coil is connected in series with the meter movement. Take a digital ohm meter and check continuity through the coil, if there is no continuity then you have probably found the problem. Unsolder the wire connected to the top of the coil (goes to the meter movement). Carefully remove the screw holding the terminal connected to the bottom of the coil (same screw that holds a rear meter connection).

EXTREME CARE MUST BE TAKEN NOT TO BEND OR DAMAGE THE NEEDLE.

Remove the screw in the center of the coil and carefully remove the coil from the meter.

In all likelihood, the wire in the coil has become brittle and unusable. You can either remove the wire from the coil form and wind a new coil (number of turns not critical) or just remove the wire and solder a 10 ohm 1/2 watt resistor across the coil form.

Replace the coil, solder the wire back on the top of the coil form and screw the back meter connection back in place.

Before re-assembling the meter, do the test again with the 1 1/2 volt battery and 3000 ohm resistor and see if the meter is now working.

When you reassemble the meter, make sure you position the needle limit springs exactly like they were.

Slide the meter face back on starting at the top left, you will have to carefully lift the end of the needle to get it started through the hole. Put the four meter face screws back in but only tighten the top two screws. Double check the position of the needle limit springs so the needle works freely but hits the limit springs just past full scale or below 0 scale. Tighten the bottom two face screws.

When you install the meter back into the tester you might also want to replace the 50uf capacitor that is across the meter. Observe polarity.