

7/89

Tektronix[®]
COMMITTED TO EXCELLENCE

**5A26
DUAL DIFFERENTIAL
AMPLIFIER**

INSTRUCTION MANUAL

7a

TEKTRONIX®

**5A26
DUAL DIFFERENTIAL
AMPLIFIER**

INSTRUCTION MANUAL

Tektronix, Inc.
P.O. Box 500
Beaverton, Oregon 97077

Serial Number _____

TABLE OF CONTENTS

	PAGE		PAGE
LIST OF ILLUSTRATIONS	i	SECTION 2 THEORY OF OPERATION	
LIST OF TABLES	i	BLOCK DIAGRAM DESCRIPTION	2-1
SECTION 1 OPERATING INSTRUCTIONS		CIRCUIT OPERATION	2-2
PREPARATION FOR USE	1-1	PREAMPLIFIER	2-2
CONTROLS, CONNECTORS, AND INDICATORS	1-1	OUTPUT AMPLIFIERS	2-3
BASIC OPERATION	1-3	READOUT (SN B019999 AND BELOW)	2-5
Preparation	1-3	READOUT (SN B020000 AND UP)	2-5
Step Attenuator Balance Adjustment	1-3	SECTION 3 REPLACEABLE ELECTRICAL PARTS	
Gain Check	1-4	SECTION 4 SERVICE INFORMATION	
DETAILED OPERATING INFORMATION	1-4	SERVICES AVAILABLE	4-1
Applying Signals	1-4	MAINTENANCE	4-1
Pre-Charging	1-4	Circuit Board Removal	4-1
Signal Input Connectors	1-4	ADJUSTMENTS AFTER REPAIR	4-1
High Impedance Input	1-5	DIAGRAMS AND CIRCUIT BOARD ILLUSTRATIONS	4-2
Display Polarity	1-5	BLOCK DIAGRAM	
Deflection Factor	1-5	ADJUSTMENT PROCEDURE	
Voltage Comparison Measurements	1-5	PARTS LOCATIONS AND DIAGRAMS	
Differential Operation	1-5	SECTION 5 REPLACEABLE MECHANICAL PARTS	
Voltage Probes	1-6	CHANGE INFORMATION	
Differential Measurements	1-6		
SPECIFICATIONS	1-7		

LIST OF ILLUSTRATIONS

FIGURE NO.		PAGE	FIGURE NO.	
1-1	5A26 Dual Differential Amplifier.	ii	4-3	Adjustment locations.
1-2	Front-panel controls, connectors and indicators.	1-2	4-4	A1, A2—Channel 1 and 2 Preamplifier circuit board component and test point locations.
1-3	Dimensions.	1-9	4-5	A1, A2—Channel 1 and 2 Preamplifier circuit board locations.
2-1	Floating Power Supply detailed block diagram showing standing current paths through the Preamplifier.	2-4	4-6	A3—Main circuit board test point locations.
			4-7	A3—Main circuit board location.
			4-8	A3—Main circuit board component locations (SN B020000 and up).
			4-9	A3—Main circuit board location.
			4-10	A3—Main circuit board component locations (SN B019999 and below).
			4-11	A3—Main circuit board location.

The illustrations in Section 4 are located on foldout pages at the back of the manual.

4-1	Circuit board locations.
4-2	Common-mode rejection (cmr) display.

LIST OF TABLES

TABLE NO.		PAGE
1-1	Electrical Specifications	1-7
1-2	Environmental Specifications	1-8
1-3	Physical Specifications	1-8

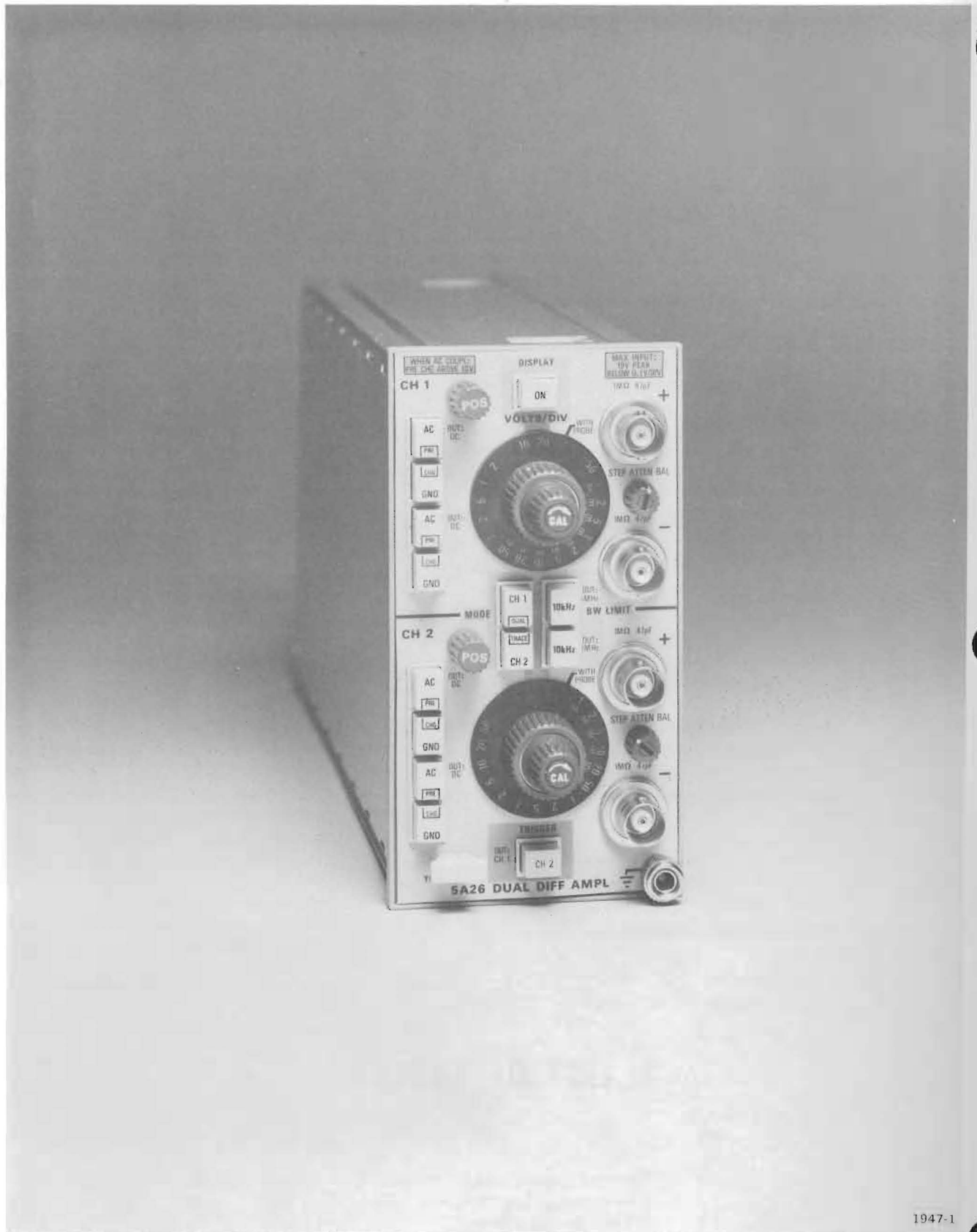

Fig. 1-1. 5A26 Dual Differential Amplifier.

OPERATING INSTRUCTIONS

The 5A26 Dual Differential Amplifier is a dual-trace high-gain differential amplifier plug-in for use with Tektronix 5000 Series Oscilloscopes. The unit contains two identical independent amplifier channels that feature high sensitivity and a high common-mode rejection ratio.

Each channel has a bandwidth capability of dc to 1 megahertz, and a front-panel push button switch allows the reduction of the upper bandwidth limit, thus increasing the signal-to-noise ratio for low frequency applications. Either channel may be used for single channel displays, or electronically switched to produce dual-trace displays.

An illuminated knob skirt provides a deflection factor readout, which is also displayed on the crt when used in an oscilloscope with readout capabilities.

PREPARATION FOR USE

The 5A26 is calibrated and ready for use when received. The unit may be installed in any plug-in compartment. Refer to the oscilloscope instruction manual for information on X-Y operation. To install, align the upper and lower grooves of the 5A26 with the plug-in compartment tracks, and fully insert the 5A26 until it locks into place. To remove, pull the release latch to disengage the 5A26 from the oscilloscope.

CONTROLS, CONNECTORS, AND INDICATORS

The following describes the function of the front-panel controls, connectors, and indicators. Refer to Fig. 1-2 for the location of the controls, connectors and indicators. More information is given under Detailed Operating Information.

- ① **DISPLAY Push Button**—Applies and removes logic levels to the oscilloscope system to enable or disable plug-in operation. Switch is functional only when plug-in is operated in one of the vertical deflection plug-in compartments.
- ② **POS Controls**—Positions display vertically.
- ③ **BW LIMIT Push Buttons**—Allows reduction of the upper bandwidth limit to increase the signal-to-noise ratio for low-frequency applications. Selects upper bandwidth limit at either 1 megahertz (button out) or 10 kilohertz (button in).
- ④ **VOLTS/DIV Switches**—Volts per major graticule division. Selects calibrated deflection factors from 50 microvolts/division to 5 volts/division; 16 steps in a 1-2-5 sequence. Knob skirt is illuminated to indicate deflection factor, and 10X scaling of both knob skirt and crt readout is provided automatically when a 10X coded probe is used.
- ⑤ **CAL (Variable VOLTS/DIV) Controls**—Provides uncalibrated continuously variable deflection factors between the calibrated settings of the VOLTS/DIV switch and extends the deflection-factor range to 12.5 volts/division.
- ⑥ **STEP ATTEN BAL Adjustments**—Balances the input amplifier for minimum trace shift throughout the deflection factor gain-switching range.
- ⑦ **Input Coupling Push Buttons**
AC—OUT:DC. Button pushed in selects capacitive coupling of signal applied to associated + or – input connector; button out selects direct coupling of input signal.
GND. Grounds the preamplifier input and connects input signal to ground through a 1 megohm resistor.
PRE CHG. Both AC and GND buttons pushed in permits precharging of the coupling capacitor to the input signal dc level. Release GND button for measurement.
- ⑧ **MODE Push Buttons**—Select channel to be displayed and illuminate the proper deflection factor setting (1X or 10X) on the VOLTS/DIV switch knob skirt. Both buttons pushed in provides a dual-trace display.

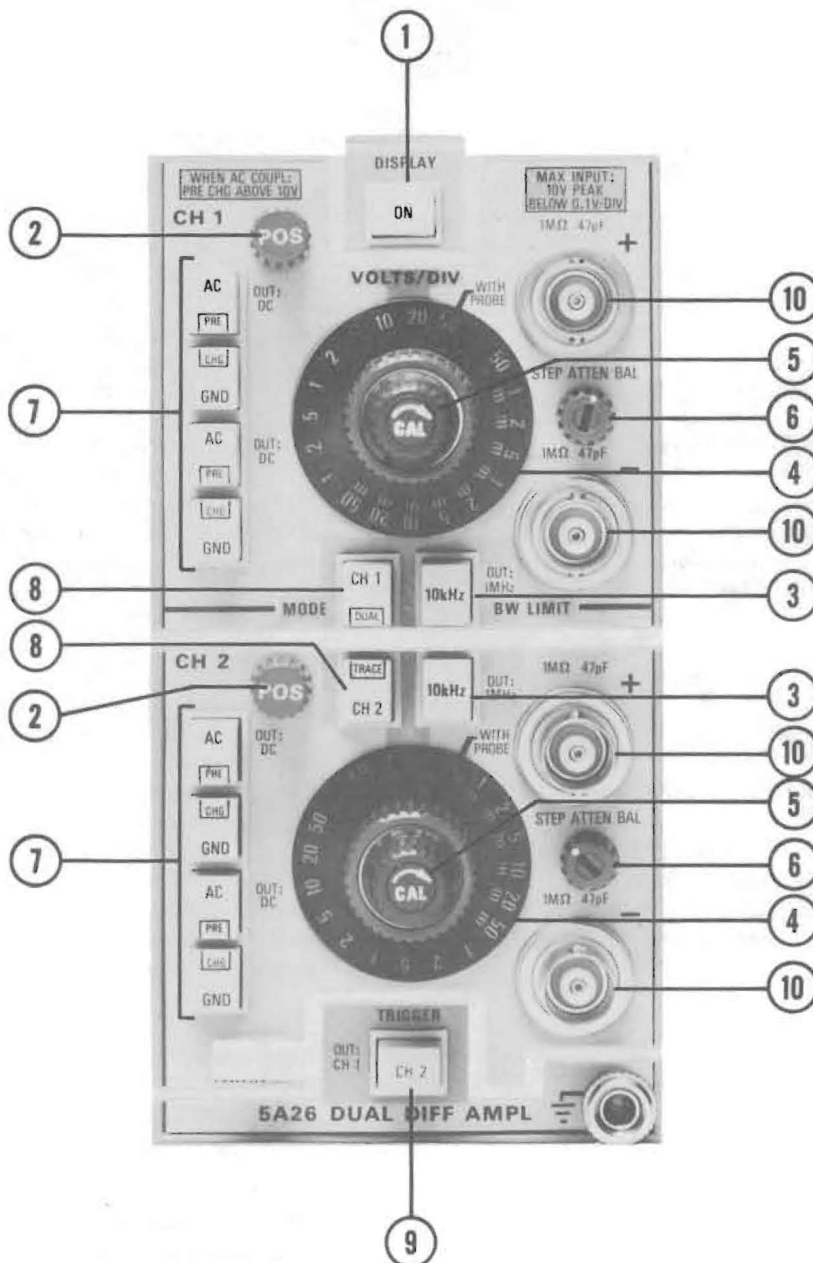

Fig. 1-2. Front-panel controls, connectors, and indicators.

9 **TRIGGER Push Button**—Selects time base triggering signal from either channel.

10 **+ and — Input Connectors**—BNC connectors for application of external voltage signals. Connector labeled + indicates that a positive-going signal will cause upward deflection; connector labeled — indicates that a positive-going signal will cause downward deflection. Connectors include coded-probe input rings for activating the readout when using readout-coded probes.

CH 1 and CH 2 — Input Coupling

AC	OUT: DC (button out)
GND	GND (button in)
MODE	CH 1 and CH 2 (buttons in)

BASIC OPERATION

Preparation

The following procedures are intended to help place the trace on the screen quickly and prepare the instrument for immediate use:

- a. Insert 5A26 all the way into oscilloscope plug-in compartment.
- b. Turn oscilloscope Intensity control to midrange and turn oscilloscope system power on. Preset time-base and triggering controls for 2 millisecond/division sweep rate and automatic triggering.
- c. Set 5A26 front-panel controls as follows:

DISPLAY	ON (button in)
TRIGGER	OUT: CH 1 (button out)
POS	Midrange
BW LIMIT	OUT: 1 MHz (button out)
VOLTS/DIV	5
STEP ATTEN BAL	Midrange
CH 1 and CH 2 + Input Coupling	
AC	OUT: DC (button out)
GND	GND (button in)

d. Adjust intensity control for normal viewing. Traces should appear near graticule center.

e. Set the VOLTS/DIV switches to .1. If traces shift, adjust the STEP ATTEN BAL control as described in Step Attenuator Balance Adjustment procedure.

f. Move CH 1 trace 2 divisions below graticule horizontal centerline, and CH 2 trace to bottom of graticule with POS controls.

g. Apply 400 millivolt peak-to-peak signal from oscilloscope calibrator loop with a test lead or 1X probe to CH 1 + input connector.

h. Release CH 1 + GND button. Display will be a square wave 4 divisions in amplitude with bottom of display at reference established in step (f).

i. Position bottom of square wave to graticule horizontal centerline.

j. Push in CH 1 + AC button and note that display shifts downward 2 divisions.

k. Disconnect test lead from CH 1 + input and connect to CH 2 + input.

l. Push in TRIGGER button for CH 2 triggering and repeat steps (f) through (j) for CH 2 operation.

Step Attenuator Balance Adjustment

When the STEP ATTEN BAL control is not properly adjusted, the display will shift vertically (due to a dc imbalance in the amplifier) as the VOLTS/DIV switch is rotated through-out its range. The shift is more noticeable on the most sensitive positions.

- a. Set VOLTS/DIV switch to 5. Ground both + and — inputs (GND buttons pushed in) and position trace to graticule horizontal centerline.
- b. Adjust STEP ATTEN BAL control for minimum trace shift as VOLTS/DIV switch is rotated throughout its range.

Gain Check

When the 5A26 is first inserted into a plug-in compartment, the amplifier gain may be checked and adjusted if necessary. See Adjustment Procedure in Section 4 of this manual for complete instructions.

DETAILED OPERATING INFORMATION

Applying Signals

CAUTION

If the maximum input voltage rating at the gates of the input FET's is exceeded, the gates are clamped at about + or — 10 volts. If the signal source can supply more than 1/16 ampere, the input protective fuse(s) will open.

When measuring unknown voltages, use the highest deflection factor first. If the deflection is too small to make the measurement, switch to a lower deflection factor.

Pre-Charging

When only the ac component of a signal having both ac and dc components is to be measured, the pre-charge circuit permits charging the coupling capacitor to the input signal dc level.

CAUTION

If the 5A26 input is connected to a large dc voltage source (10 volts peak or more), use the precharge provision. Damage to the signal source could result since the peak current through the ac coupling capacitor and the input protection circuitry is limited only by the signal source internal resistance.

- a. Before connecting 5A26 to a signal containing a dc component, push in AC and GND buttons. Then connect input to circuit under test.

- b. Wait about 1 second for coupling capacitor to charge.
- c. Release GND button and ac component can be measured in usual manner.

Signal Input Connectors

When connecting signals to the + and — input connectors on the 5A26, consider the method of coupling that will be used. Sometimes unshielded test leads can be used to connect the 5A26 to a signal source, particularly when a high level, low-frequency signal is monitored at a low impedance point. However, when any of these factors are missing, it becomes increasingly important to use shielded signal cables. In all cases, the signal-transporting leads should be kept as short as practical.

When making single-ended input measurements (conventional amplifier operation), be sure to establish a common ground connection between the device under test and the 5A26. The shield of a coaxial cable is normally used for this purpose.

In some cases, differential measurements require no common ground connection, and therefore are less susceptible to interference by ground-loop currents. Some problems with stray magnetic coupling into the signal transporting leads can also be minimized by using a differential rather than a single-ended measurement. These considerations are discussed later in this section under Differential Operation.

It is always important to consider the signal source loading (and resulting change in the source operating characteristics) due to the signal-transporting leads and the input circuit of the 5A26. The circuit at the input connectors can normally be represented by a 1 megohm resistance to ground paralleled by about 47 picofarads. A few feet of shielded cable (20 to 40 picofarads per foot) may increase the parallel capacitance to 100 picofarads or more. In many cases, the effects of these resistive and capacitive loads may be too great and it may be desirable to minimize them through the use of an attenuator probe.

Attenuator probes not only decrease the resistive-capacitive loading of a signal source, but also extend the measurement range of the 5A26 to include substantially higher voltages. Passive attenuator probes having attenuation factors of 10X, 100X, and 1000X, as well as other special-purpose types, are available through your Tektronix Field Engineer or Field Office.

Some measurement situations require an extremely high resistance input to the 5A26 with very little source loading

or signal attenuation. In such situations, a passive attenuator probe cannot be used. However, this problem may be solved by using a FET Probe or the high-impedance input provision of the 5A26 as described under High-Impedance Input.

High-Impedance Input

In the 50 m through 50 μ positions of the VOLTS/DIV switch, where the input attenuator is not used, the internal gate return resistors alone establish the 1 megohm input resistance. The removal of the strap from the Preamplifier circuit board (see Fig. 4-4, Channel 1 and 2 Preamplifier circuit board component and test point locations in the Diagrams and Parts Lists section) disconnects these resistors from ground and permits the input FET gates to float, providing a very high input impedance.

The input signal must be kept to relatively low amplitudes, since the deflection factor is restricted to 50 millivolts/division through 50 microvolts/division, and dc coupling must be used to provide a dc path for the FET gate current.

NOTE

In the 0.1 volt to 5 volt range of the VOLTS/DIV switch, the input impedance is paralleled by the resistors in the attenuator. When the strap is removed, the attenuation ratio is affected, causing the deflection factors in this range to be incorrect. To determine the deflection factor, check the deflection with an input signal of known amplitude.

The signal source impedance is an important factor, since gate current will produce an offset. For example, a 100 picoampere gate current through 10 megohms produces a 1 millivolt offset, which may result in significant error where small voltages are of concern.

The high-frequency response will also depend upon the signal source impedance, since various shunt capacitances between the source and the input gate must charge and discharge through that impedance.

Display Polarity

Single-ended signals applied to the + input connector produce a display in phase with the input signal. Signals applied to the - input connector will be inverted.

A similar polarity relationship exists for differentially applied signals, but pertains to the direction of voltage change at one input with respect to the other, rather than with respect to chassis potential.

Deflection Factor

The amount of trace deflection produced by a signal is determined by the signal amplitude, the attenuation (if any) of the probe, the setting of the VOLTS/DIV switch, and the setting of the Variable control. The deflection factor settings are calibrated only when the Variable control is rotated fully clockwise into the detent position.

The range of the Variable control is at least 2.5:1. It provides uncalibrated deflection factors covering the full range between the calibrated settings of the VOLTS/DIV switch. The Variable control can be set to extend the deflection factor to at least 12.5 volts/division.

To reduce noise and obtain a more usable display when the VOLTS/DIV switch is set to the more sensitive positions, push in the BW LIMIT button to reduce the bandwidth to 10 kHz if this limit does not appreciably distort the desired features of the signal under observation.

Voltage Comparison Measurements

Some applications require deflection factors other than the fixed values provided by the VOLTS/DIV switch. One such application is comparison of signal amplitudes by ratio rather than by absolute voltage. To accomplish this, apply a reference signal to either + or - inputs of the 5A26, and set the VOLTS/DIV switch and Variable control so that the reference display covers the desired number of graticule divisions. Do not change the Variable control settings throughout the subsequent comparisons. However, the settings of the VOLTS/DIV switch can be changed to accommodate large ratios. In doing so, regard the numbers which designate the switch positions as ratio factors rather than voltages.

Differential Operation

Single-ended measurements often yield unsatisfactory results because of interference resulting from ground-loop currents between the 5A26 and the device under test. In other cases, it may be desirable to eliminate a dc voltage by means other than the use of a dc blocking capacitor, which could limit the low-frequency response.

These limitations of single-ended measurements are effectively eliminated by connecting the + input and - input to selected points in the test circuit. Since the chassis of the 5A26 need not be connected in any way to the test circuit, there are few limitations to the selection of these test points. In any case, do not exceed the maximum safe input voltages.

The + and - AC buttons should both be set to the same positions, depending on the method of signal coupling required.

Operating Instructions—5A26

Only the voltage difference between two signals is amplified and displayed in differential measurements, while the common-mode signals (common in amplitude, frequency and phase) are rejected.

The ability of the 5A26 to reject common-mode signals is indicated by the common-mode rejection ratio (cmrr). Cmrr is at least 100,000:1 at the input connectors from 50 microvolts/division to 50 millivolts/division when signals between dc and 30 kilohertz are dc coupled to the inputs. To illustrate this characteristic, assume that a single-ended input signal consists of an unwanted 60 hertz signal of 1 volt peak-to-peak, plus a desired signal of 1 millivolt peak-to-peak. If an attempt is made to display the described signal (single-ended measurement) at 0.2 millivolts/division, the 60 hertz signal will produce a deflection equivalent to 5000 divisions and the 1 millivolt signal will be lost.

If the same 1 millivolt signal is measured differentially with the 60 hertz signal common to both inputs, no more than one part in 100,000 of the common-mode signal will appear in the display. The desired signal will produce a display of 5 divisions, with not more than 0.1 division of display produced by the common-mode signal (cmrr not specified when residual display is 0.1 division or less).

There are a number of factors which can degrade common-mode rejection. The principle requirement for maximum rejection is that the common-mode signal arrives at the input FET gates in precisely the same form. A difference of only 0.01% in the attenuation factors of the input attenuators may reduce the rejection ratio to 10,000:1. Likewise, any difference in source impedance at the two points in the source under test will degrade the rejection ratio. Attenuator probes which do not have adjustable resistance and capacitance may reduce the rejection ratio to 100:1 or less.

Outside influences such as magnetic fields can also degrade the performance, particularly when low level signals are involved. Magnetic interference may be minimized by using identical signal-transporting leads to the two inputs and twisting the two leads together over as much of their length as possible.

Voltage Probes

In general, probes offer the most convenient means of connecting a signal to the input of the 5A26. Tektronix

probes are shielded to prevent pickup of electrostatic interference. A 10X attenuator probe offers a high input impedance and allows the circuit under test to perform very close to normal operating conditions. See your Tektronix, Inc., catalog for characteristics and compatibility of probes for use with this system.

CODED PROBES. The 5A26 is designed for compatibility with coded probes, such as the Tektronix P6062A 1X/10X Passive Probe. The + and - input connectors have an outer ring to which the coding pin on the probe connector makes contact. This type of probe allows the vertical deflection factor indicated by the readout to correspond with the actual voltage at the probe tip, eliminating the need to consider the attenuation factor when measuring the signal amplitude on the graticule scale.

Differential Measurements

The following adjustment procedure is recommended when preparing to use two Tektronix P6062A probes for differential measurements in the 10X mode.

- a. Connect one probe for dc-coupled, single-ended operation to CH 1 + input. Obtain triggered display of an appropriate square wave, such as that from a calibrator or square-wave generator. Compensate probe square-wave response with probe compensation adjustment.
- b. Connect a second probe for dc-coupled operation to CH 1 - input. Apply 100 volt peak-to-peak square wave to both probes. Free-run sweep and adjust probe compensation adjustment of second probe for minimum display amplitude.
- c. Steps (a) and (b) match the probes for use at any sensitivity that employs the particular input attenuator (1X or 100X) used in steps (a) and (b). When it is necessary to use the other input attenuator, steps (a) and (b) should be repeated.
- d. Repeat steps (a), (b), and (c) for Channel 2.
- e. When examining a small differential signal in the presence of relatively large common-mode components, adjust probe by temporarily connecting both probes to either of the two signal sources.

SPECIFICATIONS

TABLE 1-1
Electrical Specifications

Characteristics	Performance Requirement
Deflection Factor	
Calibrated Range	50 μ V/div to 5 V/div in a 1, 2, 5 sequence.
Accuracy	Within 2% of deflection factor setting.
Uncalibrated Range	Variable VOLTS/DIV control provides continuously variable deflection factor between calibrated settings and extends deflection factor range to 12.5 V/div.
Frequency Response	
Bandwidth (8 Div Reference)	
DC (Direct) Coupled	
1 MHz	Dc to at least 1 MHz.
10 kHz	Dc to 10 kHz within 20%.
AC (Capacitive) Coupled	
1 MHz	2 Hz or less to at least 1 MHz.
10 kHz	2 Hz or less to 10 kHz within 20%.
Step Response	
Aberrations	+2%, -2% or less. Total not to exceed 4% p-p.
Input R and C	1 M Ω within 0.15% paralleled by approximately 47 pF.
Maximum Safe Input Voltage	
DC (Direct) Coupled	
50 μ V/Div to 50 mV/Div	10 V (dc + peak ac).
100 mV/Div to 5 V/Div	350 V (dc + peak ac).
AC (Capacitive) Coupled	
50 μ V/Div to 50 mV/Div	350 V dc (coupling capacitor pre-charged) 10 V peak ac.
100 mV/Div to 5 V/Div	350 V (dc + peak ac).
DC Rejection	
AC (Capacitive) Coupled	At least 100,000:1 after 20 minute warmup.
Input Gate Current	100 pA or less (100 μ V or less depending on external loading) at +25°C.
Common Mode Rejection	
DC (Direct) Coupled	
50 μ V/Div to 50 mV/Div	At least 100,000:1 from dc to 30 kHz with up to 20 V p-p sine wave.
100 mV/Div to 5 V/Div	At least 300:1 from dc to 30 kHz with up to 100 V p-p sine wave.

**TABLE 1-1 (CONT.)
Electrical Specifications**

Characteristics	Performance Requirement
Common Mode Rejection (continued)	
AC (Capacitive) Coupled	
50 μ V/Div to 50 mV/Div	At least 20,000:1 at 5 kHz and above, decreasing to not less than 2000:1 at 60 Hz.
With 2 P6062A Probes	400:1 at 10X probe attenuation.
Displayed Noise (Tangentially Measured)	30 μ V or less at full bandwidth.
Channel Isolation at 1 MHz (Single-Ended)	At least 100:1 with 8 div sine wave applied to one channel at 2 V/div and other channel at 1 mV/div with no signal applied.
Channel Isolation at 30 kHz (Common Mode)	50 μ V or less at any deflection factor with 20 V p-p sine wave applied to + and - inputs of either channel.

**TABLE 1-2
Environmental Specifications**

Characteristics	Performance Requirement
Temperature	
Operating	0°C to +50°C.
Storage	-55°C to +70°C.
Altitude	
Operating	To 15,000 Feet.
Storage	To 50,000 Feet.
Vibration	
Operating	15 minutes along each of 3 major axes at a total displacement of 0.015 inch with frequency varied from 10 Hz to 50 Hz to 10 Hz in 1 minute sweeps. Hold for 3 minutes at 50 Hz. All major resonances must be above 50 Hz.
Shock	
Operating and Storage	To 30 g's, 1/2 sine, 11 ms duration, 2 shocks per axis in each direction for a total of 12 shocks.

**TABLE 1-3
Physical Specifications**

Characteristics	Description
Weight	Approximately 2 lbs, 3 oz. (1 kg).
Dimensions	See Fig. 1-3, Dimensions.

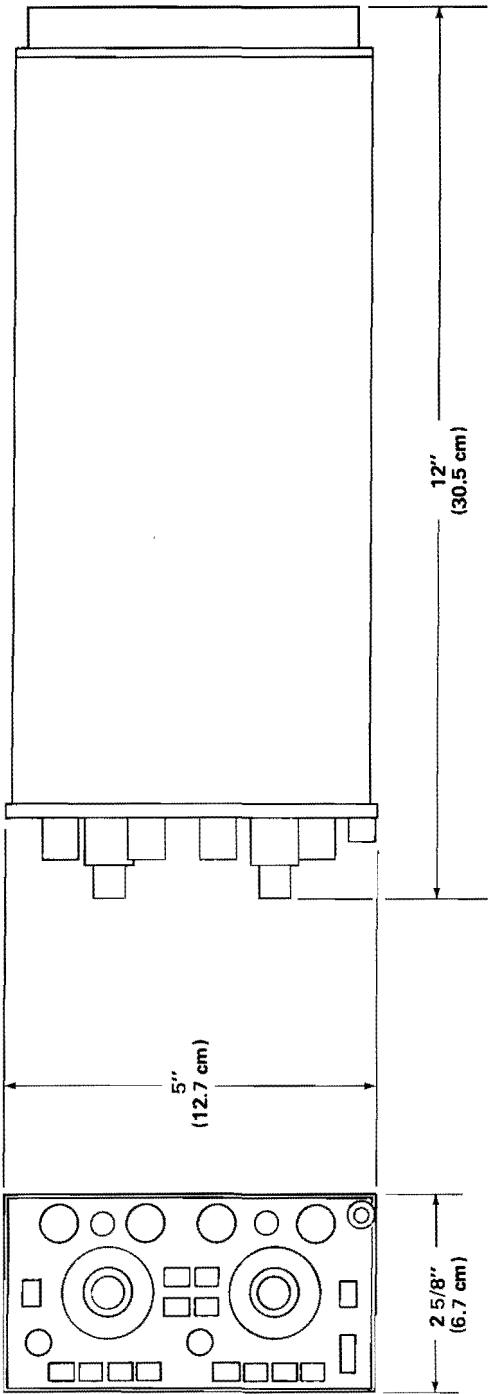

Fig. 1-3. Dimensions.

THEORY OF OPERATION

This section of the manual describes the operation of the circuits in the 5A26 Dual Differential Amplifier unit. Complete schematic diagrams and an overall block diagram of the unit are given on pullout pages at the back of this manual. The channel 1 and channel 2 circuitry is essentially identical. The following block diagram and circuit operation discussions apply to channel 1 with exceptions included where applicable.

BLOCK DIAGRAM DESCRIPTION

When the DISPLAY button is pressed, a logic level is applied to the oscilloscope to enable 5A26 operation (switch function is limited to operation in a vertical deflection compartment).

Signals applied to the + and — input connectors can be passed directly through the input coupling switches to the attenuators (dc coupled) or they can be capacitively (ac) coupled to block the dc component of the signal. The GND switch provides a ground reference to the Preamplifier input.

The Input Attenuator consists of frequency-compensated voltage dividers. 1X attenuation is provided for the 50 μ to 50 m positions of the VOLTS/DIV switch, and 100X attenuation is provided for the .1 to 5 positions. Balance to a low-frequency common-mode signal between the attenuators of the two inputs is set by adjustment of the internal LF CMR potentiometer.

From the Input Attenuator, the signal is passed directly to the Preamplifier. The inputs to the Preamplifier are fuse and diode protected. The Preamplifier consists of two identical operational amplifiers connected in a differential configuration. Common-mode signals between ground and the two inputs are rejected, due to a bootstrapped floating power supply that moves with the common-mode signal to maintain constant operating characteristics of the active devices. The difference between the two inputs is amplified. The constant current return facilitates the dc balance of the Preamplifier outputs.

From the Preamplifier, the signal is coupled directly to the Gain Switching Amplifier. Two identical operational amplifiers and a series-parallel resistor network provide the proper gain for each VOLTS/DIV switch setting.

The BW LIMIT 10 kHz switch places a capacitor across the two output lines to reduce the bandwidth and, thus, limit the noise. The signal is then passed to the Output Amplifier through an emitter-follower isolation stage.

The output differential amplifier is operated push-pull, presenting a signal to the output terminal that is of the same polarity as that applied to the Preamplifier input. The front-panel Variable VOLTS/DIV (CAL) and internal gain controls provide a means of varying the gain of the 5A26. A positioning-current driver is connected to the output lines to alter the quiescent trace position.

A triggering signal is tapped from the emitter-follower isolation stage, amplified and made available to an associated time-base plug-in unit. Triggering signal amplitude is about 0.25 volts per displayed division.

Channel switching is accomplished by the plug-in MODE buttons and the channel switch signal from the oscilloscope. Electronic switching provides a display of either or both channels (dual-trace). The switching rate in dual-trace operation is determined by the channel-switch signal repetition rate from the oscilloscope.

The VOLTS/DIV switch control is made up of a series of cams and contacts that switch input attenuators, select the proper gain-setting resistors in the Gain Switching Amplifier, and provide the proper crt readout data.

Either of two lamp bulbs behind the knob skirt on the VOLTS/DIV switch illuminate the selected deflection factor. One lamp lights for 1X deflection factor; the other lights when a readout-coded probe is attached to the + or — input connectors to indicate a 10X deflection factor.

CIRCUIT OPERATION

Circuits unique to this instrument are described in detail in this discussion. Circuits commonly used in the electronics industry are not described in detail. If more information is desired on these commonly used circuits, refer to the following textbooks.

Phillip Cutler, "Semiconductor Circuit Analysis", McGraw-Hill, New York, 1964.

Jacob Millman and Herbert Taub, "Pulse Digital and Switching Waveforms", McGraw-Hill, New York, 1965.

Albert Paul Malvino, "Transistor Circuit Approximations", McGraw-Hill, New York, 1973.

Gordon V. Deboo, "Integrated Circuits and Semiconductor Devices", McGraw-Hill, New York, 1971.

Lloyd P. Hunter (Ed.), "Handbook of Semiconductor Electronics", third edition, McGraw-Hill, New York, 1970.

The numbers inside the diamonds after a heading refer to the schematic diagram for that circuit located at the back of this manual.

PREAMPLIFIER 1

Plug-In Logic

When DISPLAY button is pressed, a logic level is applied to the electronic switching circuit in the oscilloscope to enable plug-in operation. Power is applied to illuminate the VOLTS/DIV knob skirt behind the proper deflection factor when the MODE button is pressed in.

Input Coupling

Signals applied to the front-panel + and - input connectors may be capacitive coupled (ac), direct coupled (dc) or internally grounded through a capacitor and resistor. Input coupling is selected by means of two push button switches at each input; S2C and D for the + input and S2A and B for the - input.

A signal applied to the + input with both buttons in the out position (dc coupled) is passed directly to the Input Attenuator. When the AC button is pressed in, C12 is placed in the circuit to ac couple signals of about 2 hertz (-3 dB point) and higher to the attenuator. Capacitor C12 blocks any dc component of the signal. When the GND button is pressed in, a ground reference is provided to the input of the amplifier without the need to remove the applied signal from the input connector.

NOTE

When ac coupled with dc levels of 10 volts or more, both the AC and GND buttons should be pressed in (PRE CHG) while input connections are made or broken, or when voltage levels are changed. This allows the coupling capacitor to charge without opening the input fuses or overdriving the amplifier.

Input Attenuators

The Input Attenuators consist of frequency-compensated voltage dividers that provide 100X attenuation in the .1 to 5 positions of the VOLTS/DIV switch. For dc and low-frequency signals, the dividers are essentially resistive (attenuation ratio determined by the resistance ratio). Balance between the attenuators of the two inputs for low-frequency common-mode signals is set by adjusting R9, LF CMR. At higher frequencies, the capacitive reactance becomes effective and the impedance ratio determines the attenuation.

In addition to providing constant 100X attenuation at all frequencies within the bandwidth capabilities of the instrument, the Input Attenuator maintains a constant input RC characteristic (1 megohm paralleled by about 47 picofarads) for the .1 to 5 positions of the VOLTS/DIV switch.

Input Protection

Input protection consists of fuses F20 and F30 and diodes CR21, CR24, CR31, and CR34. If the signal should reach a level sufficient to forward bias one of the protection diodes (a potential greater than about 12.5 volts), current will be conducted through that diode, protecting the input FET's. If that current should exceed the fuse rating, the fuse(s) will open.

Preamplifier

The Preamplifier consists of two identical operational amplifiers connected in a differential configuration.

The operational amplifiers consist of Q54A, Q60A, and Q64A on the - input side, and Q54B, Q60B and Q64B on the + input side. Transistors Q54A and Q54B provide a

voltage follower input to output transistors Q64A and Q64B while Q60A provides additional open-loop gain. Total gain of the stage is determined by R58 and R78 between the two amplifiers, and resistors R64 and R84.

Quiescently, the two sides of the amplifier are balanced. When a differential signal is applied to the gates of Q54A and Q54B, signal current is developed through resistors R58 and R78. Conduction of Q64A and Q64B is changed by the amount of signal current with the output voltage developed across R64 and R84. The output is a push-pull signal, opposite in polarity to the signal applied to the inputs.

To minimize trace shift as different vertical deflection factors are selected, the outputs at the Q64A and Q64B collectors are dc balanced at equal potentials so that the voltage across the gain-setting resistors in the Gain-Switching Amplifier is zero at all settings of the VOLTS/DIV switch. This dc balancing is achieved by adjusting R89, Atten Bal Range and R72, STEP ATTEN BAL.

Common-Mode Rejection

One of the primary functions of the Preamplifier is to reject any common-mode component of the input signal and amplify only the difference. Assume that the inputs are tied together and a voltage is applied to the common input. The amplifier differential output is ideally zero, and would actually be zero provided that the characteristics of all corresponding elements on the two sides of the amplifier were matched (e.g., Q54A and Q54B transconductance and μ , Q60A and Q60B beta, current sources, etc.). In practice, any mismatch will cause a differential output.

Floating Power Supply

A Floating Power Supply consisting of Q39, Q44, Q48, and Zener diodes VR40 and VR42 minimizes inherent common-mode difficulties and, therefore, improves the common-mode rejection ratio (refer to Fig. 2-1). Transistor Q44 is a constant-current high-impedance source, and Q39 is the current return.

The input to the bootstrap (X1 gain) amplifier is connected to the junction of R58 and R78. The bootstrap amplifier portion of the supply consists of emitter-follower Q48 and dc level-shifting Zener diodes VR40 and VR42. The collector impedance of Q39 presents minimum loading to the Q48 output and maintains the gain of the amplifier (bootstrap efficiency) very close to one.

The entire power supply and amplifier voltages move an amount equal to the common-mode voltage to maintain a

constant operating characteristic of the elements in the Preamplifier stage. Since no common-mode signal current is developed, the output at the collectors of Q64A and Q64B remains unchanged; that is, the common-mode signal is rejected.

Variable capacitor C59, HF CMR, is adjusted to normalize the effective capacitance of the active devices on one side of the amplifier to the other.

OUTPUT AMPLIFIERS



Gain-Switching Amplifier

The Gain-Switching Amplifier consists of two identical operational amplifiers.

The operational amplifiers consist of Q205A, Q208A, and Q210A on the – input side and Q205B, Q208B, and Q210B on the + input side. Total gain of the stage is determined by R210, R220 and the setting of the VOLTS/DIV control which selects the series-parallel combination of R203, R213, and R228 through R236.

Potentiometer R225, Var Bal 1, located in the collector circuit of transistors Q210A, and Q210B, is adjusted with no input signal to set the voltage across the Variable VOLTS/DIV control, R264, in the Output Amplifier stage to zero volts. With both sides of the amplifier balanced, trace deflection is prevented as the Variable VOLTS/DIV control is rotated throughout its range.

Normally, the frequency response of the Gain Switching Amplifier is from dc to at least 1 megahertz, however, for low-frequency applications where high input sensitivities are used, the overall frequency response can be limited to about 10 kilohertz to reduce noise referred to the input. This is achieved by pushing in the BW LIMIT 10 kHz switch, S239, which connects C239 across the output of the Gain Switching Amplifier.

Isolation Stage

The differential signal developed at the collectors of Q210A and Q210B is passed through emitter followers Q242 and Q252 to the Output Amplifier. Transistors Q242 and Q252 isolate the Gain Switching Amplifier from the loading of the Output Amplifier and Trigger Amplifier.

Output Amplifier

The Output Amplifier consists of push-pull amplifiers Q260 and Q270. With a signal applied, potentiometer R273, Gain 1,

provides emitter degeneration. The gain is determined by the total emitter resistance which allows the overall gain of the 5A26 to be adjusted to match the mainframe requirements. Also, the Variable VOLTS/DIV control, R264, provides continuously variable gain to 2.5 times the calibrated deflection factor setting.

Transistors Q267 and Q277 are positioning-current drivers. Position (POS) control, R274, provides an adjustable change in the conduction of the transistors to provide a current that either adds to or subtracts from the Q260-Q270 currents to alter the quiescent vertical position of the display.

Channel Switching

Channel switching is accomplished by Q282, Q292, Q286 and Q386. The channel switch signal from the mainframe through pin B21 sets the bias on Q386 while the bias on Q286 is determined by the MODE buttons. The bias level at the base of Q286 relative to that at the base of Q386 determines which of these transistors is on. With the CH 1 MODE button pressed in and the CH 2 MODE button out, the bias level on Q286 is lower (more negative) than that at Q386, which turns Q286 off and Q386 on. With Q286 turned off, +5 volts dc through R286 reverse-biases diodes CR283 and CR293, which turns on Q282 and Q292 in the channel switch stage. Thus, the channel 1 signal is coupled to the mainframe through interface connector pins A7 and B7.

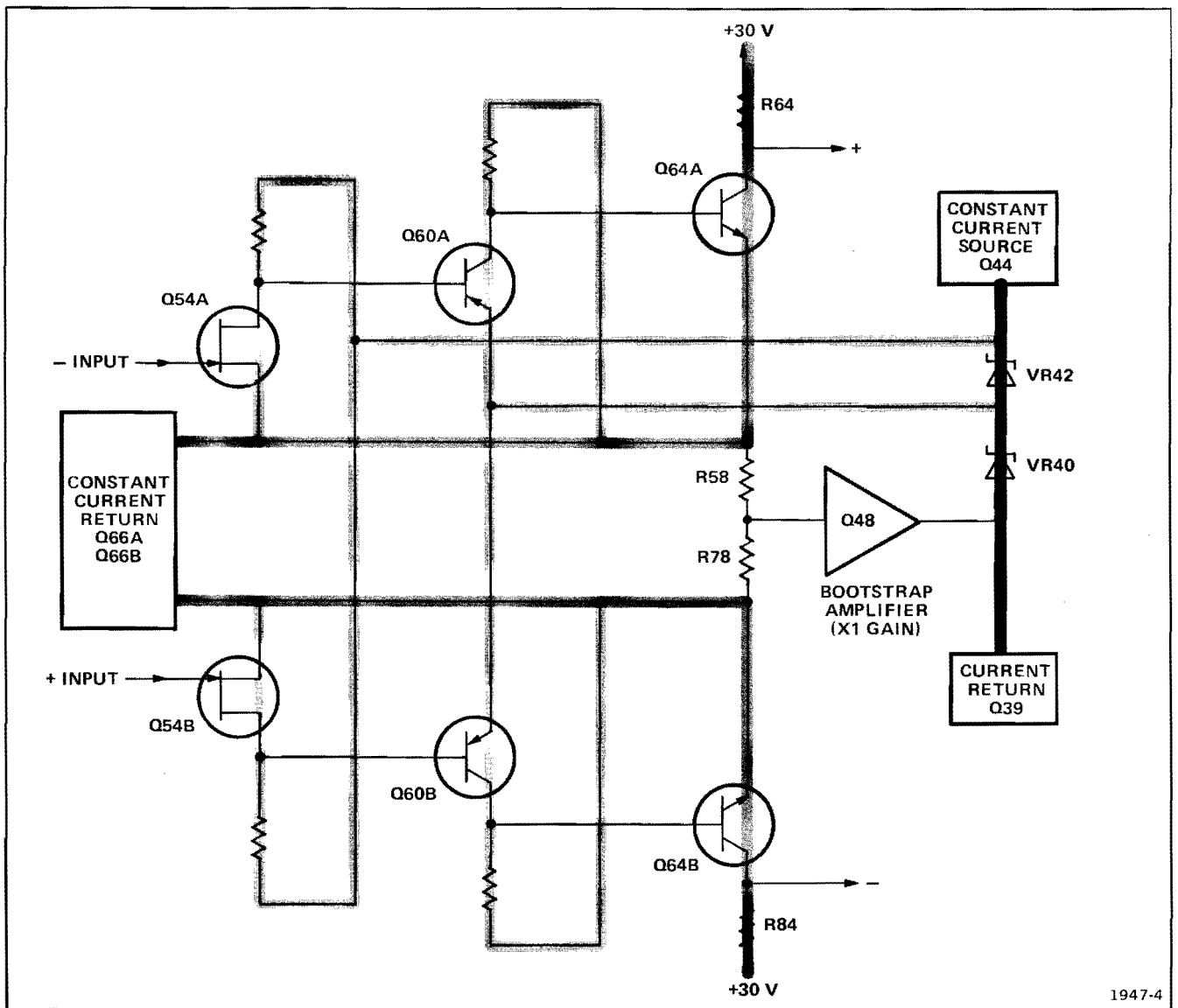

Fig. 2-1. Floating Power Supply detailed block diagram showing standing current paths through the Preamplifier.

While Q286 is off, Q386 is on and draws current from the +5 volt dc supply through R386. The resultant voltage across R386 turns off Q382 and Q392 in the Channel Switch stage. Thus, the channel 2 signal is not coupled to the mainframe.

When the CH 2 MODE button is pressed in, the bias level on Q286 is higher (less negative) than that at Q386, which turns Q286 on and Q386 off. The conditions described for the channel 1 mode are then reversed.

For dual-trace operation (both CH 1 and CH 2 MODE buttons pushed in), a 0 to +5 volts repetitive signal is applied from the mainframe to the base of Q386 through pin B21. Thus, the bias level on Q386 alternates above and below the bias level on Q286 which turns on channel 1, then channel 2, at a rate determined by the repetition rate of the channel switch signal at pin B21.

Trigger Amplifier

Differential amplifier Q245 and Q255 receives the triggering signal from the emitters of Q242 and Q252 in the isolation stage of the Output Amplifier. The triggering signal is amplified and passed through TRIGGER switch S401 to transistor Q404 where it is made available to an associated time-base unit via pin A4. The triggering signal is of the same polarity as that applied to the gate of Q54B and has an amplitude of about 0.25 volts per displayed division.

Vertical Switching

VOLTS/DIV switch S20 contains a series of cam lobes which engage and disengage various contacts at different positions of the switch. Cams 1, 2, 4, and 5 control switching of the Input Attenuator and cams 11 through 19 control switching of gain-setting network resistors R228 through R236 in the Gain-Switching Amplifier stage. Those contacts that are engaged at any VOLTS/DIV switch position are shown by black dots on the switch logic diagram.

READOUT (SN B019999 AND BELOW)

Deflection Factor (VOLTS/DIV Knob Skirt and Crt)

Either of two lamp bulbs (DS417 or DS421) located behind the VOLTS/DIV knob skirt illuminate the selected deflection factor to provide a direct readout. Normally, DS421 is lit to indicate a 1X deflection factor. Connecting a readout-coded 10X probe to either input (with the GND buttons out) automatically changes the crt readout by a factor of 10 and lights DS417 to indicate a 10X deflection factor.

With a 10X readout-coded probe connected to the - input, the probe-coding resistor is connected in parallel with R410 through the probe-coding ring. The probe resistor biases Q417 on, which turns on indicator DS417. Consequently, Q421 turns off and extinguishes indicator DS421. The probe-coding resistor in parallel with R410 also changes the bias on Q450 which changes the crt readout. When the DISPLAY button is out, illuminating voltage is removed from indicators DS417 and DS421, and Q484 is gated off. Thus, indicators DS417 and DS421 are extinguished, and the crt readout is blanked.

With a 10X readout-coded probe connected to the + input, R413 functions the same as R410 in the - input circuit. Thus, a 10X readout-coded probe connected to either or both inputs will provide a 10X readout on the VOLTS/DIV knob skirt and on the crt.

When pressed in, contacts of GND switches S2D (+ input) and S2B (- input) open the circuit between the + and - input probe-coding rings and the readout circuitry. Consequently, with a readout-coded probe connected to both inputs and both + and - GND buttons pressed in, the VOLTS/DIV knob skirt and crt will indicate a 1X deflection factor. If only one of the GND buttons is pressed in, the VOLTS/DIV knob skirt and crt will indicate a 10X deflection factor.

If the probe-coding ring on the + or - input connector is grounded, DS417 lights to indicate a 10X deflection factor and the crt readout is extinguished. The crt readout is determined by the VOLTS/DIV control which establishes the bias on Q458, Q466 and Q474. Changing the bias on the base of these transistors also changes the emitter voltage thereby changing the voltage across their associated emitter resistors. The current drawn from pin A28 through Q458, Q466, or Q474 and their associated emitter resistors determines the crt readout.

READOUT (SN B020000 AND UP)

Deflection Factor (VOLTS/DIV Knob Skirt and Crt)

Either of two lamp bulbs (DS417 or DS421) located behind the VOLTS/DIV knob skirt illuminate the selected deflection factor to provide a direct readout. Normally, DS417 is lit to indicate a 1X deflection factor. Connecting a readout-coded 10X probe to either input (with the GND buttons out) automatically changes the crt readout by a factor of 10 and lights DS421 to indicate a 10X deflection factor.

Theory of Operation—5A26

With a 10X readout-coded probe connected to the + or – input, the probe-coding resistor (through the probe-coding ring) biases Q415 on, which turns off Q417 and indicator DS417. Consequently, this turns on Q421 and indicator DS421. The probe-coding resistor also changes the bias on Q450 which changes the crt readout. When the DISPLAY button is out, illuminating voltage is removed from indicators DS417 and DS421, and Q484 is gated off. Thus, indicators DS417 and DS421 are extinguished, and the crt readout is blanked.

When pressed in, contacts of GND switches S2D (+ input) and S2B (– input) open the circuit between the + and – input probe-coding rings and the readout circuitry. Consequently, with a readout-coded probe connected to both inputs and with both + and – GND buttons pressed in, the

VOLTS/DIV knob skirt and crt will indicate a 1X deflection factor. If only one of the GND buttons is pressed in, the VOLTS/DIV knob skirt and crt will indicate a 10X deflection factor.

If the probe-coding ring on the + or – input connector is grounded, DS421 lights to indicate a 10X deflection factor and the crt readout is extinguished. The crt readout is determined by the VOLTS/DIV control which establishes the bias on Q458, Q466 and Q474. Changing the bias on the base of these transistors also changes the emitter voltage thereby changing the voltage across their associated emitter resistors. The current drawn from pin A28 through Q458, Q466, or Q474 and their associated emitter resistors determines the crt readout.

REPLACEABLE ELECTRICAL PARTS

PARTS ORDERING INFORMATION

Replacement parts are available from or through your local Tektronix, Inc. Field Office or representative.

Changes to Tektronix instruments are sometimes made to accommodate improved components as they become available, and to give you the benefit of the latest circuit improvements developed in our engineering department. It is therefore important, when ordering parts, to include the following information in your order: Part number, instrument type or number, serial number, and modification number if applicable.

If a part you have ordered has been replaced with a new or improved part, your local Tektronix, Inc. Field Office or representative will contact you concerning any change in part number.

Change information, if any, is located at the rear of this manual.

SPECIAL NOTES AND SYMBOLS

X000 Part first added at this serial number

00X Part removed after this serial number

ITEM NAME

In the Parts List, an Item Name is separated from the description by a colon (:). Because of space limitations, an Item Name may sometimes appear as incomplete. For further Item Name identification, the U.S. Federal Cataloging Handbook H6-1 can be utilized where possible.

ABBREVIATIONS

ACTR	ACTUATOR	PLSTC	PLASTIC
ASSY	ASSEMBLY	QTZ	QUARTZ
CAP	CAPACITOR	RECP	RECEPTACLE
CER	CERAMIC	RES	RESISTOR
CKT	CIRCUIT	RF	RADIO FREQUENCY
COMP	COMPOSITION	SEL	SELECTED
CONN	CONNECTOR	SEMICOND	SEMICONDUCTOR
ELCTLT	ELECTROLYTIC	SENS	SENSITIVE
ELEC	ELECTRICAL	VAR	VARIABLE
INCAND	INCANDESCENT	WW	WIREWOUND
LED	LIGHT EMITTING DIODE	XFMR	TRANSFORMER
NONWIR	NON WIREWOUND	XTAL	CRYSTAL

CROSS INDEX—MFR. CODE NUMBER TO MANUFACTURER

Mfr. Code	Manufacturer	Address	City, State, Zip
00853	SANGAMO ELECTRIC CO., S. CAROLINA DIV.	P O BOX 128	PICKENS, SC 29671
01121	ALLEN-BRADLEY COMPANY	1201 2ND STREET SOUTH	MILWAUKEE, WI 53204
03508	GENERAL ELECTRIC COMPANY, SEMI-CONDUCTOR PRODUCTS DEPARTMENT	ELECTRONICS PARK	SYRACUSE, NY 13201
07263	FAIRCHILD SEMICONDUCTOR, A DIV. OF FAIRCHILD CAMERA AND INSTRUMENT CORP.	464 ELLIS STREET	MOUNTAIN VIEW, CA 94042
08806	GENERAL ELECTRIC CO., MINIATURE LAMP PRODUCTS DEPARTMENT	NELA PARK	CLEVELAND, OH 44112
24546	CORNING GLASS WORKS, ELECTRONIC COMPONENTS DIVISION	550 HIGH STREET	BRADFORD, PA 16701
24931	SPECIALTY CONNECTOR CO., INC.	3560 MADISON AVE.	INDIANAPOLIS, IN 46227
32293	INTERSIL, INC.	10900 N. TANTAU AVE.	CUPERTINO, CA 95014
53944	ELT INC., GLOW LITE DIVISION	BOX 698	PAULS VALLEY, OK 73075
56289	SPRAGUE ELECTRIC CO.		NORTH ADAMS, MA 01247
71400	BUSSMAN MFG., DIVISION OF MCGRAW-EDISON CO.	2536 W. UNIVERSITY ST.	ST. LOUIS, MO 63107
72982	ERIE TECHNOLOGICAL PRODUCTS, INC.	644 W. 12TH ST.	ERIE, PA 16512
73138	BECKMAN INSTRUMENTS, INC., HELIPOT DIV.	2500 HARBOR BLVD.	FULLERTON, CA 92634
75042	TRW ELECTRONIC COMPONENTS, IRC FIXED RESISTORS, PHILADELPHIA DIVISION	401 N. BROAD ST.	PHILADELPHIA, PA 19108
80009	TEKTRONIX, INC.	P O BOX 500	BEAVERTON, OR 97077
80031	ELECTRA-MIDLAND CORP., MEPCO DIV.	22 COLUMBIA ROAD	MORRISTOWN, NJ 07960
91637	DALE ELECTRONICS, INC.	P. O. BOX 609	COLUMBUS, NE 68601

Ckt No.	Tektronix Part No.	Serial/Model No. Eff	Dscont	Name & Description	Mfr Code	Mfr Part Number
A1	670-3150-00			CKT BOARD ASSY:PRE AMPLIFIER CH1	80009	670-3150-00
A2	670-3150-00			CKT BOARD ASSY:PRE AMPLIFIER CH2	80009	670-3150-00
A3	670-3143-00	B010100	B019999	CKT BOARD ASSY:MAIN	80009	670-3143-00
A3	670-3143-01	B020000		CKT BOARD ASSY:MAIN	80009	670-3143-01
C2	295-0181-00			CAP SET,MATCHED: (C2 AND C12 FURNISHED AS A UNIT. INDIVIDUAL TIMING CAPACITORS IN THIS ASSY MUST BE ORDERED BY THE 9-DIGIT PART #, LETTER SUFFIX AND TOLERANCE PRINTED ON THE TIMING CAP. TO BE REPLACED. THE LETTER SUFFIX AND THE TOLERANCE SHOULD BE THE SAME FOR ALL OF THE TIMING CAPS IN THE ASSY. I.E.285-XXXX-XX F-)	80009	295-0181-00
C4	281-0182-00			CAP.,VAR,PLSTC:1.8-10PF,500V	80031	2805D1R810BH02F0
C5	281-0182-00			CAP.,VAR,PLSTC:1.8-10PF,500V	80031	2805D1R810BH02F0
C6	281-0184-00			CAP.,VAR,PLSTC:2-18PF,500VDC	80031	2805D00218BN02F0
C7	281-0508-00			CAP.,FXD,CER DI:12PF,+/-0.6PF,500V	72982	301-000C0G0120J
C8	283-0626-00			CAP.,FXD,MICA D:1800PF,5%,500V	00853	D195E182J0
C12	295-0181-00			CAP.,SET,MATCHED: (C2 AND C12 FURNISHED AS A UNIT. ALSO SEE FOOTNOTE ON C2)	80009	295-0181-00
C14	281-0182-00			CAP.,VAR,PLSTC:1.8-10PF,500V	80031	2805D1R810BH02F0
C15	281-0182-00			CAP.,VAR,PLSTC:1.8-10PF,500V	80031	2805D1R810BH02F0
C16	281-0184-00			CAP.,VAR,PLSTC:2-18PF,500VDC	80031	2805D00218BN02F0
C17	281-0508-00			CAP.,FXD,CER DI:12PF,+/-0.6PF,500V	72982	301-000C0G0120J
C18	283-0626-00			CAP.,FXD,MICA D:1800PF,5%,500V	00853	D195E182J0
C23	290-0522-00			CAP.,FXD,ELCTLT:1UF,20%,50V	56289	196D105X0050HA1
C25	290-0522-00			CAP.,FXD,ELCTLT:1UF,20%,50V	56289	196D105X0050HA1
C40	290-0535-00			CAP.,FXD,ELCTLT:33UF,20%,10V	56289	196D336X0010KA1
C42	290-0535-00			CAP.,FXD,ELCTLT:33UF,20%,10V	56289	196D336X0010KA1
C43	281-0513-00			CAP.,FXD,CER DI:27PF,+/-5.4PF,500V	72982	301-000P2G0270M
C45	290-0522-00			CAP.,FXD,ELCTLT:1UF,20%,50V	56289	196D105X0050HA1
C54	281-0578-00			CAP.,FXD,CER DI:18PF,5%,500V	72982	301-050C0G0180J
C59	281-0178-00			CAP.,VAR,PLSTC:1-3.5PF,500V	80031	2805D013R5BH02F0
C60	281-0503-00			CAP.,FXD,CER DI:8PF,+/-0.5PF,500V	72982	301-000C0H0809D
C72	283-0003-00			CAP.,FXD,CER DI:0.01UF,+80-20%,150V	72982	855-55825U-103Z
C74	281-0578-00			CAP.,FXD,CER DI:18PF,5%,500V	72982	301-050C0G0180J
C79	281-0534-00			CAP.,FXD,CER DI:3.3PF,+/-0.25PF,500V	72982	301-000C0J0339C
C80	281-0503-00			CAP.,FXD,CER DI:8PF,+/-0.5PF,500V	72982	301-000C0H0809D
C94	283-0080-00			CAP.,FXD,CER DI:0.022UF,+80-20%,25V	56289	19C611
C96	281-0629-00			CAP.,FXD,CER DI:33PF,5%,600V	72982	308-000C0G0330J
C97	283-0003-00			CAP.,FXD,CER DI:0.01UF,+80-20%,150V	72982	855-55825U-103Z
C98	290-0522-00			CAP.,FXD,ELCTLT:1UF,20%,50V	56289	196D105X0050HA1
C99	290-0522-00			CAP.,FXD,ELCTLT:1UF,20%,50V	56289	196D105X0050HA1
C102	295-0181-00			CAP.,SET,MATCHED:TO 1% 285-1025-00 (C102 AND C112 FURNISHED AS A UNIT. ALSO SEE FOOTNOTE ON C2)	80009	295-0181-00
C104	281-0182-00			CAP.,VAR,PLSTC:1.8-10PF,500V	80031	2805D1R810BH02F0
C105	281-0182-00			CAP.,VAR,PLSTC:1.8-10PF,500V	80031	2805D1R810BH02F0
C106	281-0184-00			CAP.,VAR,PLSTC:2-18PF,500VDC	80031	2805D00218BN02F0
C107	281-0508-00			CAP.,FXD,CER DI:12PF,+/-0.6PF,500V	72982	301-000C0G0120J
C108	283-0626-00			CAP.,FXD,MICA D:1800PF,5%,500V	00853	D195E182J0
C112	295-0181-00			CAP.,SET,MATCHED:TO 1% 285-1025-00 (C102 AND C112 FURNISHED AS A UNIT. ALSO SEE FOOTNOTE ON C2)	80009	295-0181-00
C114	281-0182-00			CAP.,VAR,PLSTC:1.8-10PF,500V	80031	2805D1R810BH02F0
C115	281-0182-00			CAP.,VAR,PLSTC:1.8-10PF,500V	80031	2805D1R810BH02F0
C116	281-0184-00			CAP.,VAR,PLSTC:2-18PF,500VDC	80031	2805D00218BN02F0
C117	281-0508-00			CAP.,FXD,CER DI:12PF,+/-0.6PF,500V	72982	301-000C0G0120J

Replaceable Electrical Parts—5A26

Ckt No.	Tektronix Part No.	Serial/Model No. Eff	Dscont	Name & Description	Mfr Code	Mfr Part Number
C118	283-0626-00			CAP., FXD, MICA D:1800PF, 5%, 500V	00853	D195E182J0
C123	290-0522-00			CAP., FXD, ELCTLT:1UF, 20%, 50V	56289	196D105X0050HA1
C125	290-0522-00			CAP., FXD, ELCTLT:1UF, 20%, 50V	56289	196D105X0050HA1
C140	290-0535-00			CAP., FXD, ELCTLT:33UF, 20%, 10V	56289	196D336X0010KA1
C142	290-0535-00			CAP., FXD, ELCTLT:33UF, 20%, 10V	56289	196D336X0010KA1
C143	281-0513-00			CAP., FXD, CER DI:27PF, +/-5.4PF, 500V	72982	301-000P2G0270M
C145	290-0522-00			CAP., FXD, ELCTLT:1UF, 20%, 50V	56289	196D105X0050HA1
C154	281-0578-00			CAP., FXD, CER DI:18PF, 5%, 500V	72982	301-050C0G0180J
C159	281-0178-00			CAP., VAR, PLSTC:1-3.5PF, 500V	80031	2805D013R5BH02F0
C160	281-0503-00			CAP., FXD, CER DI:8PF, +/-0.5PF, 500V	72982	301-000C0H0809D
C172	283-0003-00			CAP., FXD, CER DI:0.01UF, +80-20%, 150V	72982	855-558Z5U-103Z
C174	281-0578-00			CAP., FXD, CER DI:18PF, 5%, 500V	72982	301-050C0G0180J
C179	281-0534-00			CAP., FXD, CER DI:3.3PF, +/-0.25PF, 500V	72982	301-000C0J0339C
C180	281-0503-00			CAP., FXD, CER DI:8PF, +/-0.5PF, 500V	72982	301-000C0H0809D
C194	283-0080-00			CAP., FXD, CER DI:0.022UF, +80-20%, 25V	56289	19C611
C196	281-0629-00			CAP., FXD, CER DI:33PF, 5%, 600V	72982	308-000C0G0330J
C197	283-0003-00			CAP., FXD, CER DI:0.01UF, +80-20%, 150V	72982	855-558Z5U-103Z
C198	290-0522-00			CAP., FXD, ELCTLT:1UF, 20%, 50V	56289	196D105X0050HA1
C199	290-0522-00			CAP., FXD, ELCTLT:1UF, 20%, 50V	56289	196D105X0050HA1
C202	281-0604-00			CAP., FXD, CER DI:2.2PF, +/-0.25PF, 500V	72982	301-000C0J0229C
C207	281-0503-00			CAP., FXD, CER DI:8PF, +/-0.5PF, 500V	72982	301-000C0H0809D
C212	281-0604-00			CAP., FXD, CER DI:2.2PF, +/-0.25PF, 500V	72982	301-000C0J0229C
C217	281-0503-00			CAP., FXD, CER DI:8PF, +/-0.5PF, 500V	72982	301-000C0H0809D
C239	283-0041-00			CAP., FXD, CER DI:0.0033UF, 5%, 500V	72982	841-541B332J
C266	283-0003-00			CAP., FXD, CER DI:0.01UF, +80-20%, 150V	72982	855-558Z5U-103Z
C276	283-0003-00			CAP., FXD, CER DI:0.01UF, +80-20%, 150V	72982	855-558Z5U-103Z
C288	283-0000-00			CAP., FXD, CER DI:0.001UF, +100-0%, 500V	72982	831-516E102P
C302	281-0604-00			CAP., FXD, CER DI:2.2PF, +/-0.25PF, 500V	72982	301-000C0J0229C
C307	281-0503-00			CAP., FXD, CER DI:8PF, +/-0.5PF, 500V	72982	301-000C0H0809D
C312	281-0604-00			CAP., FXD, CER DI:2.2PF, +/-0.25PF, 500V	72982	301-000C0J0229C
C317	281-0503-00			CAP., FXD, CER DI:8PF, +/-0.5PF, 500V	72982	301-000C0H0809D
C339	283-0041-00			CAP., FXD, CER DI:0.0033UF, 5%, 500V	72982	841-541B332J
C366	283-0003-00			CAP., FXD, CER DI:0.01UF, +80-20%, 150V	72982	855-558Z5U-103Z
C376	283-0003-00			CAP., FXD, CER DI:0.01UF, +80-20%, 150V	72982	855-558Z5U-103Z
C389	281-0578-00			CAP., FXD, CER DI:18PF, 5%, 500V	72982	301-050C0G0180J
C401	283-0003-00			CAP., FXD, CER DI:0.01UF, +80-20%, 150V	72982	855-558Z5U-103Z
C407	290-0522-00			CAP., FXD, ELCTLT:1UF, 20%, 50V	56289	196D105X0050HA1
C415	283-0081-00	B010100	B019999	CAP., FXD, CER DI:0.1UF, +80-20%, 25V	56289	36C600
C415	283-0003-00	B020000		CAP., FXD, CER DI:0.01UF, +80-20%, 150V	72982	855-558Z5U-103Z
C435	283-0081-00	B010100	B019999	CAP., FXD, CER DI:0.1UF, +80-20%, 25V	56289	36C600
C435	283-0003-00	B020000		CAP., FXD, CER DI:0.01UF, +80-20%, 150V	72982	855-558Z5U-103Z
C445	283-0002-00	B010100	B019999X	CAP., FXD, CER DI:0.01UF, +80-20%, 500V	72982	811-546E103Z
C592	290-0522-00			CAP., FXD, ELCTLT:1UF, 20%, 50V	56289	196D105X0050HA1
C594	290-0522-00			CAP., FXD, ELCTLT:1UF, 20%, 50V	56289	196D105X0050HA1
CR21	152-0323-00			SEMICON D DEVICE:SILICON, 35V, 0.1A	80009	152-0323-00
CR24	152-0323-00			SEMICON D DEVICE:SILICON, 35V, 0.1A	80009	152-0323-00
CR31	152-0323-00			SEMICON D DEVICE:SILICON, 35V, 0.1A	80009	152-0323-00
CR34	152-0323-00			SEMICON D DEVICE:SILICON, 35V, 0.1A	80009	152-0323-00
CR121	152-0323-00			SEMICON D DEVICE:SILICON, 35V, 0.1A	80009	152-0323-00
CR124	152-0323-00			SEMICON D DEVICE:SILICON, 35V, 0.1A	80009	152-0323-00
CR131	152-0323-00			SEMICON D DEVICE:SILICON, 35V, 0.1A	80009	152-0323-00
CR134	152-0323-00			SEMICON D DEVICE:SILICON, 35V, 0.1A	80009	152-0323-00
CR224	152-0141-02			SEMICON D DEVICE:SILICON, 30V, 50NA	80009	152-0141-02
CR246	152-0141-02			SEMICON D DEVICE:SILICON, 30V, 50NA	80009	152-0141-02
CR280	152-0141-02			SEMICON D DEVICE:SILICON, 30V, 50NA	80009	152-0141-02
CR283	152-0141-02			SEMICON D DEVICE:SILICON, 30V, 50NA	80009	152-0141-02

Ckt No.	Tektronix Part No.	Serial/Model No. Eff	Dscont	Name & Description	Mfr Code	Mfr Part Number
CR286	152-0141-02			SEMICON D DEVICE: SILICON, 30V, 50NA	80009	152-0141-02
CR290	152-0141-02			SEMICON D DEVICE: SILICON, 30V, 50NA	80009	152-0141-02
CR293	152-0141-02			SEMICON D DEVICE: SILICON, 30V, 50NA	80009	152-0141-02
CR324	152-0141-02			SEMICON D DEVICE: SILICON, 30V, 50NA	80009	152-0141-02
CR346	152-0141-02			SEMICON D DEVICE: SILICON, 30V, 50NA	80009	152-0141-02
CR380	152-0141-02			SEMICON D DEVICE: SILICON, 30V, 50NA	80009	152-0141-02
CR383	152-0141-02			SEMICON D DEVICE: SILICON, 30V, 50NA	80009	152-0141-02
CR386	152-0141-02			SEMICON D DEVICE: SILICON, 30V, 50NA	80009	152-0141-02
CR390	152-0141-02			SEMICON D DEVICE: SILICON, 30V, 50NA	80009	152-0141-02
CR393	152-0141-02			SEMICON D DEVICE: SILICON, 30V, 50NA	80009	152-0141-02
CR411	152-0141-02			SEMICON D DEVICE: SILICON, 30V, 50NA	80009	152-0141-02
CR414	152-0141-02			SEMICON D DEVICE: SILICON, 30V, 50NA	80009	152-0141-02
CR420	152-0141-02	XB020000		SEMICON D DEVICE: SILICON, 30V, 50NA	80009	152-0141-02
CR426	152-0141-02	XB020000		SEMICON D DEVICE: SILICON, 30V, 50NA	80009	152-0141-02
CR431	152-0141-02			SEMICON D DEVICE: SILICON, 30V, 50NA	80009	152-0141-02
CR434	152-0141-02			SEMICON D DEVICE: SILICON, 30V, 50NA	80009	152-0141-02
CR478	152-0141-02			SEMICON D DEVICE: SILICON, 30V, 50NA	80009	152-0141-02
CR483	152-0141-02			SEMICON D DEVICE: SILICON, 30V, 50NA	80009	152-0141-02
CR528	152-0141-02			SEMICON D DEVICE: SILICON, 30V, 50NA	80009	152-0141-02
CR533	152-0141-02			SEMICON D DEVICE: SILICON, 30V, 50NA	80009	152-0141-02
DS417	150-0111-00	B010100	B019999	LAMP, GLOW: NEON, 1.2MA	53944	A1B-3
DS417	150-0130-00	B020000		LAMP, INCAND: 5V, 60MA	08806	2200DX
DS421	150-0111-00	B010100	B019999	LAMP, GLOW: NEON, 1.2MA	53944	A1B-3
DS421	150-0130-00	B020000		LAMP, INCAND: 5V, 60MA	08806	2200DX
DS437	150-0111-00	B010100	B019999	LAMP, GLOW: NEON, 1.2MA	53944	A1B-3
DS437	150-0130-00	B020000		LAMP, INCAND: 5V, 60MA	08806	2200DX
DS441	150-0111-00	B010100	B019999	LAMP, GLOW: NEON, 1.2MA	53944	A1B-3
DS441	150-0130-00	B020000		LAMP, INCAND: 5V, 60MA	08806	2200DX
F20	159-0024-00			FUSE, CARTRIDGE: 3AG, 0.06A, 250V, FAST BLOW	71400	AGC 1/16
F30	159-0024-00			FUSE, CARTRIDGE: 3AG, 0.06A, 250V, FAST BLOW	71400	AGC 1/16
F120	159-0024-00			FUSE, CARTRIDGE: 3AG, 0.06A, 250V, FAST BLOW	71400	AGC 1/16
F130	159-0024-00			FUSE, CARTRIDGE: 3AG, 0.06A, 250V, FAST BLOW	71400	AGC 1/16
J1	131-1171-00			CONNECTOR, RCPT, : BNC, 50 OHM	24931	28JR231-1
J11	131-1171-00			CONNECTOR, RCPT, : BNC, 50 OHM	24931	28JR231-1
J101	131-1171-00			CONNECTOR, RCPT, : BNC, 50 OHM	24931	28JR231-1
J111	131-1171-00			CONNECTOR, RCPT, : BNC, 50 OHM	24931	28JR231-1
L592	108-0245-00			COIL, RF: 3.9UH	80009	108-0245-00
L594	108-0245-00			COIL, RF: 3.9UH	80009	108-0245-00
Q39	151-0341-00			TRANSISTOR: SILICON, NPN	80009	151-0341-00
Q44	151-0342-00			TRANSISTOR: SILICON, PNP	80009	151-0342-00
Q48	151-0432-00			TRANSISTOR: SILICON, NPN	80009	151-0432-00
Q54A, B	151-1031-00			TRANSISTOR: SILICON, FE, N-CHANNEL, DUAL	80009	151-1031-00
Q60A, B	151-0261-00	B010100	B051709	TRANSISTOR: SILICON, PNP, DUAL	80009	151-0261-00
A60A, B	151-0261-01	B051710		TRANSISTOR: SILICON, PNP, DUAL, LOW NOISE	80009	151-0261-01
Q64A, B	151-0232-00			TRANSISTOR: SILICON, NPN, DUAL	80009	151-0232-00
Q66A, B	151-0232-00			TRANSISTOR: SILICON, NPN, DUAL	80009	151-0232-00
Q139	151-0341-00			TRANSISTOR: SILICON, NPN	80009	151-0341-00
Q144	151-0342-00			TRANSISTOR: SILICON, PNP	80009	151-0342-00
Q148	151-0432-00			TRANSISTOR: SILICON, NPN	80009	151-0432-00
Q154A, B	151-1031-00			TRANSISTOR: SILICON, FE, N-CHANNEL, DUAL	80009	151-1031-00
Q160A, B	151-0261-00	B010100	B051709	TRANSISTOR: SILICON, PNP, DUAL	80009	151-0261-00
Q160A, B	151-0261-01	B051710		TRANSISTOR: SILICON, PNP, DUAL, LOW NOISE	80009	151-0261-01
Q164A, B	151-0232-00			TRANSISTOR: SILICON, NPN, DUAL	80009	151-0232-00
Q166A, B	151-0232-00			TRANSISTOR: SILICON, NPN, DUAL	80009	151-0232-00

Replaceable Electrical Parts—5A26

Ckt No.	Tektronix Part No.	Serial/Model No. Eff	Dscont	Name & Description	Mfr Code	Mfr Part Number
Q205A, B	151-0353-00			TRANSISTOR: SILICON, NPN	32293	ITS1251
Q208A, B	151-0261-00	B010100	B051709	TRANSISTOR: SILICON, PNP, DUAL	80009	151-0261-00
Q208A, B	151-0261-01	B051710		TRANSISTOR: SILICON, PNP, DUAL, LOW NOISE	80009	151-0261-01
Q210A, B	151-0232-00			TRANSISTOR: SILICON, NPN, DUAL	80009	151-0232-00
Q242	151-0341-00			TRANSISTOR: SILICON, NPN	80009	151-0341-00
Q245	151-0342-00			TRANSISTOR: SILICON, PNP	80009	151-0342-00
Q252	151-0341-00			TRANSISTOR: SILICON, NPN	80009	151-0341-00
Q255	151-0342-00			TRANSISTOR: SILICON, PNP	80009	151-0342-00
Q260	151-0342-00			TRANSISTOR: SILICON, PNP	80009	151-0342-00
Q267	151-0341-00			TRANSISTOR: SILICON, NPN	80009	151-0341-00
Q270	151-0342-00			TRANSISTOR: SILICON, PNP	80009	151-0342-00
Q277	151-0341-00			TRANSISTOR: SILICON, NPN	80009	151-0341-00
Q282	151-1005-00			TRANSISTOR: SILICON, JFE, N-CHANNEL	80009	151-1005-00
Q286	151-0341-00			TRANSISTOR: SILICON, NPN	80009	151-0341-00
Q292	151-1005-00			TRANSISTOR: SILICON, JFE, N-CHANNEL	80009	151-1005-00
Q305A, B	151-0353-00			TRANSISTOR: SILICON, NPN	32293	ITS1251
Q308A, B	151-0261-00	B010100	B051709	TRANSISTOR: SILICON, PNP, DUAL	80009	151-0261-00
Q308A, B	151-0261-01	B051710		TRANSISTOR: SILICON, PNP, DUAL, LOW, NOISE	80009	151-0261-01
Q310A, B	151-0232-00			TRANSISTOR: SILICON, NPN, DUAL	80009	151-0232-00
Q342	151-0341-00			TRANSISTOR: SILICON, NPN	80009	151-0341-00
Q345	151-0342-00			TRANSISTOR: SILICON, PNP	80009	151-0342-00
Q352	151-0341-00			TRANSISTOR: SILICON, NPN	80009	151-0341-00
Q355	151-0342-00			TRANSISTOR: SILICON, PNP	80009	151-0342-00
Q360	151-0342-00			TRANSISTOR: SILICON, PNP	80009	151-0342-00
Q367	151-0341-00			TRANSISTOR: SILICON, NPN	80009	151-0341-00
Q370	151-0342-00			TRANSISTOR: SILICON, PNP	80009	151-0342-00
Q377	151-0341-00			TRANSISTOR: SILICON, NPN	80009	151-0341-00
Q382	151-1005-00			TRANSISTOR: SILICON, JFE, N-CHANNEL	80009	151-1005-00
Q386	151-0273-00	B010100	B029999	TRANSISTOR: SILICON, NPN	80009	151-0273-00
Q386	151-0341-00	B030000		TRANSISTOR: SILICON, NPN	80009	151-0341-00
Q392	151-1005-00			TRANSISTOR: SILICON, JFE, N-CHANNEL	80009	151-1005-00
Q404	151-0341-00			TRANSISTOR: SILICON, NPN	80009	151-0341-00
Q415	151-0190-00	XB020000		TRANSISTOR: SILICON, NPN	07263	S032677
Q417	151-0347-00	B010100	B019999	TRANSISTOR: SILICON, NPN	80009	151-0347-00
Q417	151-0254-00	B020000		TRANSISTOR: SILICON, NPN	80009	151-0254-00
Q421	151-0347-00	B010100	B019999	TRANSISTOR: SILICON, NPN	80009	151-0347-00
Q421	151-0254-00	B020000		TRANSISTOR: SILICON, NPN	80009	151-0254-00
Q425	151-0342-00			TRANSISTOR: SILICON, PNP	80009	151-0342-00
Q435	151-0190-00	XB020000		TRANSISTOR: SILICON, NPN	07263	S032677
Q437	151-0347-00	B010100	B019999	TRANSISTOR: SILICON, NPN	80009	151-0347-00
Q437	151-0254-00	B020000		TRANSISTOR: SILICON, NPN	80009	151-0254-00
Q441	151-0347-00	B010100	B019999	TRANSISTOR: SILICON, NPN	80009	151-0347-00
Q441	151-0254-00	B020000		TRANSISTOR: SILICON, NPN	80009	151-0254-00
Q450	151-0281-00			TRANSISTOR: SILICON, NPN	03508	X16P4039
Q458	151-0281-00			TRANSISTOR: SILICON, NPN	03508	X16P4039
Q466	151-0281-00			TRANSISTOR: SILICON, NPN	03508	X16P4039
Q474	151-0281-00			TRANSISTOR: SILICON, NPN	03508	X16P4039
Q484	151-1005-00			TRANSISTOR: SILICON, JFE, N-CHANNEL	80009	151-1005-00
Q500	151-0281-00			TRANSISTOR: SILICON, NPN	03508	X16P4039
Q508	151-0281-00			TRANSISTOR: SILICON, NPN	03508	X16P4039
Q516	151-0281-00			TRANSISTOR: SILICON, NPN	03508	X16P4039
Q524	151-0281-00			TRANSISTOR: SILICON, NPN	03508	X16P4039
Q534	151-1005-00			TRANSISTOR: SILICON, JFE, N-CHANNEL	80009	151-1005-00
R2	315-0105-00			RES., FXD, CMPSN: 1M OHM, 5%, 0.25W	01121	CB1055
R4	315-0270-00			RES., FXD, CMPSN: 27 OHM, 5%, 0.25W	01121	CB2705
R5	322-0624-07			RES., FXD, FILM: 990K OHM, 0.1%, 0.25W	75042	CEBTO-9903B
R8	321-0289-03			RES., FXD, FILM: 10K OHM, 0.25%, 0.125W	91637	MFF1816D10001C

Ckt No.	Tektronix Part No.	Serial/Model No. Eff	Dscont	Name & Description	Mfr Code	Mfr Part Number
R9	311-0605-00			RES., VAR, NONWIR: 200 OHM, 10%, 0.50W	73138	82-23-1
R12	315-0105-00			RES., FXD, CMPSN: 1M OHM, 5%, 0.25W	01121	CB1055
R14	315-0270-00			RES., FXD, CMPSN: 27 OHM, 5%, 0.25W	01121	CB2705
R15	322-0624-07			RES., FXD, FILM: 990K OHM, 0.1%, 0.25W	75042	CEBTO-9903B
R18	321-0289-03			RES., FXD, FILM: 10K OHM, 0.25%, 0.125W	91637	MFF1816D10001C
R20	322-0481-07			RES., FXD, FILM: 1M OHM, 0.1%, 0.25W	91637	MFF1421C1003B
R23	315-0153-00			RES., FXD, CMPSN: 15K OHM, 5%, 0.25W	01121	CB1535
R25	315-0153-00			RES., FXD, CMPSN: 15K OHM, 5%, 0.25W	01121	CB1535
R30	322-0481-07			RES., FXD, FILM: 1M OHM, 0.1%, 0.25W	91637	MFF1421C1003B
R36	315-0153-00			RES., FXD, CMPSN: 15K OHM, 5%, 0.25W	01121	CB1535
R37	315-0153-00			RES., FXD, CMPSN: 15K OHM, 5%, 0.25W	01121	CB1535
R39	315-0113-00			RES., FXD, CMPSN: 11K OHM, 5%, 0.25W	01121	CB1135
R43	315-0270-00			RES., FXD, CMPSN: 27 OHM, 5%, 0.25W	01121	CB2705
R45	315-0151-00			RES., FXD, CMPSN: 150 OHM, 5%, 0.25W	01121	CB1515
R47	315-0362-00			RES., FXD, CMPSN: 3.6K OHM, 5%, 0.25W	01121	CB3625
R49	315-0222-00			RES., FXD, CMPSN: 2.2K OHM, 5%, 0.25W	01121	CB2225
R51	315-0101-00			RES., FXD, CMPSN: 100 OHM, 5%, 0.25W	01121	CB1015
R53	321-0235-00			RES., FXD, FILM: 2.74K OHM, 1%, 0.125W	91637	MFF1816G27400F
R54	315-0512-00			RES., FXD, CMPSN: 5.1K OHM, 5%, 0.25W	01121	CB5125
R56	321-0126-00			RES., FXD, FILM: 200 OHM, 1%, 0.125W	91637	MFF1816G200ROF
R58	321-0928-07			RES., FXD, FILM: 250 OHM, 0.1%, 0.125W	91637	MFF1816C250ROB
R62	321-0207-00			RES., FXD, FILM: 1.4K OHM, 1%, 0.125W	91637	MFF1816G14000F
R64	321-0193-03			RES., FXD, FILM: 1K OHM, 0.25%, 0.125W	91637	MFF1816D10000C
R66	321-0135-00			RES., FXD, FILM: 249 OHM, 1%, 0.125W	91637	MFF1816G249ROF
R68	321-0235-00			RES., FXD, FILM: 2.74K OHM, 1%, 0.125W	91637	MFF1816G27400F
R69	315-0121-00			RES., FXD, CMPSN: 120 OHM, 5%, 0.25W	01121	CB1215
R70	315-0331-00			RES., FXD, CMPSN: 330 OHM, 5%, 0.25W	01121	CB3315
R71	315-0101-00			RES., FXD, CMPSN: 100 OHM, 5%, 0.25W	01121	CB1015
R72	311-1064-00			RES., VAR, NONWIR: 500 OHM, 10%, 0.50W	01121	WA1G032S501UA
R73	321-0235-00			RES., FXD, FILM: 2.74K OHM, 1%, 0.125W	91637	MFF1816G27400F
R74	315-0512-00			RES., FXD, CMPSN: 5.1K OHM, 5%, 0.25W	01121	CB5125
R76	321-0126-00			RES., FXD, FILM: 200 OHM, 1%, 0.125W	91637	MFF1816G200ROF
R78	321-0928-07			RES., FXD, FILM: 250 OHM, 0.1%, 0.125W	91637	MFF1816C250ROB
R82	321-0207-00			RES., FXD, FILM: 1.4K OHM, 1%, 0.125W	91637	MFF1816G14000F
R84	321-0193-03			RES., FXD, FILM: 1K OHM, 0.25%, 0.125W	91637	MFF1816D10000C
R86	321-0135-00			RES., FXD, FILM: 249 OHM, 1%, 0.125W	91637	MFF1816G249ROF
R88	321-0235-00			RES., FXD, FILM: 2.74K OHM, 1%, 0.125W	91637	MFF1816G27400F
R89	311-0605-00			RES., VAR, NONWIR: 200 OHM, 10%, 0.50W	73138	82-23-1
R94	321-0638-00			RES., FXD, FILM: 7.96K OHM, 1%, 0.125W	24546	NA55D7961F
R95	321-0289-00			RES., FXD, FILM: 10K OHM, 1%, 0.125W	91637	MFF1816G10001F
R98	315-0100-00			RES., FXD, CMPSN: 10 OHM, 5%, 0.25W	01121	CB1005
R99	315-0100-00			RES., FXD, CMPSN: 10 OHM, 5%, 0.25W	01121	CB1005
R102	315-0105-00			RES., FXD, CMPSN: 1M OHM, 5%, 0.25W	01121	CB1055
R104	315-0270-00			RES., FXD, CMPSN: 27 OHM, 5%, 0.25W	01121	CB2705
R105	322-0624-07			RES., FXD, FILM: 990K OHM, 0.1%, 0.25W	75042	CEBTO-9903B
R108	321-0289-03			RES., FXD, FILM: 10K OHM, 0.25%, 0.125W	91637	MFF1816D10001C
R109	311-0605-00			RES., VAR, NONWIR: 200 OHM, 10%, 0.50W	73138	82-23-1
R112	315-0105-00			RES., FXD, CMPSN: 1M OHM, 5%, 0.25W	01121	CB1055
R114	315-0270-00			RES., FXD, CMPSN: 27 OHM, 5%, 0.25W	01121	CB2705
R115	322-0624-07			RES., FXD, FILM: 990K OHM, 0.1%, 0.25W	75042	CEBTO-9903B
R118	321-0289-03			RES., FXD, FILM: 10K OHM, 0.25%, 0.125W	91637	MFF1816D10001C
R120	322-0481-07			RES., FXD, FILM: 1M OHM, 0.1%, 0.25W	91637	MFF1421C1003B
R123	315-0153-00			RES., FXD, CMPSN: 15K OHM, 5%, 0.25W	01121	CB1535
R125	315-0153-00			RES., FXD, CMPSN: 15K OHM, 5%, 0.25W	01121	CB1535
R130	322-0481-07			RES., FXD, FILM: 1M OHM, 0.1%, 0.25W	91637	MFF1421C1003B
R136	315-0153-00			RES., FXD, CMPSN: 15K OHM, 5%, 0.25W	01121	CB1535
R137	315-0153-00			RES., FXD, CMPSN: 15K OHM, 5%, 0.25W	01121	CB1535

Replaceable Electrical Parts—5A26

Ckt No.	Tektronix Part No.	Serial/Model No. Eff	Dscont	Name & Description	Mfr Code	Mfr Part Number
R139	315-0113-00			RES., FXD, CMPSN: 11K OHM, 5%, 0.25W	01121	CB1135
R143	315-0270-00			RES., FXD, CMPSN: 27 OHM, 5%, 0.25W	01121	CB2705
R145	315-0151-00			RES., FXD, CMPSN: 150 OHM, 5%, 0.25W	01121	CB1515
R147	315-0362-00			RES., FXD, CMPSN: 3.6K OHM, 5%, 0.25W	01121	CB3625
R149	315-0222-00			RES., FXD, CMPSN: 2.2K OHM, 5%, 0.25W	01121	CB2225
R151	315-0101-00			RES., FXD, CMPSN: 100 OHM, 5%, 0.25W	01121	CB1015
R153	321-0235-00			RES., FXD, FILM: 2.74K OHM, 1%, 0.125W	91637	MFF1816G27400F
R154	315-0512-00			RES., FXD, CMPSN: 5.1K OHM, 5%, 0.25W	01121	CB5125
R156	321-0126-00			RES., FXD, FILM: 200 OHM, 1%, 0.125W	91637	MFF1816G200R0F
R158	321-0928-07			RES., FXD, FILM: 250 OHM, 0.1%, 0.125W	91637	MFF1816G250R0B
R162	321-0207-00			RES., FXD, FILM: 1.4K OHM, 1%, 0.125W	91637	MFF1816G14000F
R164	321-0193-03			RES., FXD, FILM: 1K OHM, 0.25%, 0.125W	91637	MFF1816D10000C
R166	321-0135-00			RES., FXD, FILM: 249 OHM, 1%, 0.125W	91637	MFF1816G249R0F
R168	321-0235-00			RES., FXD, FILM: 2.74K OHM, 1%, 0.125W	91637	MFF1816G27400F
R169	315-0121-00			RES., FXD, CMPSN: 120 OHM, 5%, 0.25W	01121	CB1215
R170	315-0331-00			RES., FXD, CMPSN: 330 OHM, 5%, 0.25W	01121	CB3315
R171	315-0101-00			RES., FXD, CMPSN: 100 OHM, 5%, 0.25W	01121	CB1015
R172	311-1064-00			RES., VAR, NONWIR: 500 OHM, 10%, 0.50W	01121	WA1G032S501UA
R173	321-0235-00			RES., FXD, FILM: 2.74K OHM, 1%, 0.125W	91637	MFF1816G27400F
R174	315-0512-00			RES., FXD, CMPSN: 5.1K OHM, 5%, 0.25W	01121	CB5125
R176	321-0126-00			RES., FXD, FILM: 200 OHM, 1%, 0.125W	91637	MFF1816G200R0F
R178	321-0928-07			RES., FXD, FILM: 250 OHM, 0.1%, 0.125W	91637	MFF1816G250R0B
R182	321-0207-00			RES., FXD, FILM: 1.4K OHM, 1%, 0.125W	91637	MFF1816G14000F
R184	321-0193-03			RES., FXD, FILM: 1K OHM, 0.25%, 0.125W	91637	MFF1816D10000C
R186	321-0135-00			RES., FXD, FILM: 249 OHM, 1%, 0.125W	91637	MFF1816G249R0F
R188	321-0235-00			RES., FXD, FILM: 2.74K OHM, 1%, 0.125W	91637	MFF1816G27400F
R189	311-0605-00			RES., VAR, NONWIR: 200 OHM, 10%, 0.50W	73138	82-23-1
R194	321-0638-00			RES., FXD, FILM: 7.96K OHM, 1%, 0.125W	24546	NA55D7961F
R195	321-0289-00			RES., FXD, FILM: 10K OHM, 1%, 0.125W	91637	MFF1816G10001F
R198	315-0100-00			RES., FXD, CMPSN: 10 OHM, 5%, 0.25W	01121	CB1005
R199	315-0100-00			RES., FXD, CMPSN: 10 OHM, 5%, 0.25W	01121	CB1005
R201	315-0101-00			RES., FXD, CMPSN: 100 OHM, 5%, 0.25W	01121	CB1015
R203	321-0816-03			RES., FXD, FILM: 5K OHM, 0.25%, 0.125W	91637	MFF1816D50000C
R204	321-0193-03			RES., FXD, FILM: 1K OHM, 0.25%, 0.125W	91637	MFF1816D10000C
R205	321-0256-00			RES., FXD, FILM: 4.53K OHM, 1%, 0.125W	91637	MFF1816G45300F
R208	321-0278-00			RES., FXD, FILM: 7.68K OHM, 1%, 0.125W	91637	MFF1816G76800F
R210	321-0231-00			RES., FXD, FILM: 2.49K OHM, 1%, 0.125W	91637	MFF1816G24900F
R211	315-0101-00			RES., FXD, CMPSN: 100 OHM, 5%, 0.25W	01121	CB1015
R213	321-0816-03			RES., FXD, FILM: 5K OHM, 0.25%, 0.125W	91637	MFF1816D50000C
R214	321-0193-03			RES., FXD, FILM: 1K OHM, 0.25%, 0.125W	91637	MFF1816D10000C
R215	321-0256-00			RES., FXD, FILM: 4.53K OHM, 1%, 0.125W	91637	MFF1816G45300F
R218	321-0278-00			RES., FXD, FILM: 7.68K OHM, 1%, 0.125W	91637	MFF1816G76800F
R220	321-0231-00			RES., FXD, FILM: 2.49K OHM, 1%, 0.125W	91637	MFF1816G24900F
R225	311-1567-00			RES., VAR, NONWIR: TRMR, 100 OHM, 0.50W	73138	91-89-0
R228	321-0933-03			RES., FXD, FILM: 6.66K OHM, 0.25%, 0.125W	91637	MFF1816D66600C
R229	321-0932-03			RES., FXD, FILM: 2.5K OHM, 0.25%, 0.125W	91637	MFF1816D25000C
R230	321-0931-03			RES., FXD, FILM: 1.11K OHM, 0.25%, 0.125W	91637	MFF1816D11100C
R231	321-0660-03			RES., FXD, FILM: 417 OHM, 0.25%, 0.125W	91637	MFF1816D417ROC
R232	321-0930-03			RES., FXD, FILM: 204 OHM, 0.25%, 0.125W	91637	MFF1816D204ROC
R233	321-1097-03			RES., FXD, FILM: 101 OHM, 0.25%, 0.125W	91637	MFF1816D101ROC
R234	321-0030-03			RES., FXD, FILM: 20.0 OHM, 0.25%, 0.125W	91637	MFF1816D20R00C
R236	321-0030-03			RES., FXD, FILM: 20.0 OHM, 0.25%, 0.125W	91637	MFF1816D20R00C
R243	315-0203-00			RES., FXD, CMPSN: 20K OHM, 5%, 0.25W	01121	CB2035
R244	315-0331-00			RES., FXD, CMPSN: 330 OHM, 5%, 0.25W	01121	CB3315
R246	315-0203-00			RES., FXD, CMPSN: 20K OHM, 5%, 0.25W	01121	CB2035
R247	321-0222-00			RES., FXD, FILM: 2K OHM, 1%, 0.125W	91637	MFF1816G20000F
R248	315-0331-00			RES., FXD, CMPSN: 330 OHM, 5%, 0.25W	01121	CB3315

Ckt No.	Tektronix Part No.	Serial/Model No. Eff	Dscont	Name & Description	Mfr Code	Mfr Part Number
R253	315-0203-00			RES., FXD, CMPSN: 20K OHM, 5%, 0.25W	01121	CB2035
R254	315-0331-00			RES., FXD, CMPSN: 330 OHM, 5%, 0.25W	01121	CB3315
R258	315-0331-00			RES., FXD, CMPSN: 330 OHM, 5%, 0.25W	01121	CB3315
R259	321-0228-00			RES., FXD, FILM: 2.32K OHM, 1%, 0.125W	91637	MFF1816G23200F
R262	321-0286-00			RES., FXD, FILM: 9.31K OHM, 1%, 0.125W	91637	MFF1816G93100F
R263	321-0215-00			RES., FXD, FILM: 1.69K OHM, 1%, 0.125W	91637	MFF1816G16900F
R264	311-1403-00			RES., VAR, NONWIR: 5K OHM, 20%, 0.50W (FURNISHED AS A UNIT WITH S478)	01121	10M922
R265	321-0260-00			RES., FXD, FILM: 4.99K OHM, 1%, 0.125W	91637	MFF1816G49900F
R266	321-0193-00			RES., FXD, FILM: 1K OHM, 1%, 0.125W	91637	MFF1816G10000F
R268	321-0324-00			RES., FXD, FILM: 23.2K OHM, 1%, 0.125W	91637	MFF1816G23201F
R272	321-0286-00			RES., FXD, FILM: 9.31K OHM, 1%, 0.125W	91637	MFF1816G93100F
R273	311-1565-00			RES., VAR, NONWIR: 250 OHM, 20%, 0.50W	73138	91A R250
R274	311-0546-00			RES., VAR, NONWIR: 10K OHM, 20%, 0.75W	80009	311-0546-00
R275	321-0323-00			RES., FXD, FILM: 22.6K OHM, 1%, 0.125W	91637	MFF1816G22601F
R276	321-0193-00			RES., FXD, FILM: 1K OHM, 1%, 0.125W	91637	MFF1816G10000F
R278	321-0324-00			RES., FXD, FILM: 23.2K OHM, 1%, 0.125W	91637	MFF1816G23201F
R279	315-0122-00			RES., FXD, CMPSN: 1.2K OHM, 5%, 0.25W	01121	CB1225
R280	315-0470-00			RES., FXD, CMPSN: 47 OHM, 5%, 0.25W	01121	CB4705
R282	321-0247-00			RES., FXD, FILM: 3.65K OHM, 1%, 0.125W	91637	MFF1816G36500F
R284	321-0159-00			RES., FXD, FILM: 442 OHM, 1%, 0.125W	91637	MFF1816G442R0F
R286	315-0153-00			RES., FXD, CMPSN: 15K OHM, 5%, 0.25W	01121	CB1535
R287	321-0289-00			RES., FXD, FILM: 10K OHM, 1%, 0.125W	91637	MFF1816G10001F
R288	321-0289-00			RES., FXD, FILM: 10K OHM, 1%, 0.125W	91637	MFF1816G10001F
R289	315-0303-00	B010100	B029999	RES., FXD, CMPSN: 30K OHM, 5%, 0.25W	01121	CB3035
R289	315-0203-00	B030000		RES., FXD, CMPSN: 20K OHM, 5%, 0.25W	01121	CB2035
R290	315-0470-00			RES., FXD, CMPSN: 47 OHM, 5%, 0.25W	01121	CB4705
R292	321-0247-00			RES., FXD, FILM: 3.65K OHM, 1%, 0.125W	91637	MFF1816G36500F
R294	321-0159-00			RES., FXD, FILM: 442 OHM, 1%, 0.125W	91637	MFF1816G442R0F
R298	315-0222-00			RES., FXD, CMPSN: 2.2K OHM, 5%, 0.25W	01121	CB2225
R301	315-0101-00			RES., FXD, CMPSN: 100 OHM, 5%, 0.25W	01121	CB1015
R303	321-0816-03			RES., FXD, FILM: 5K OHM, 0.25%, 0.125W	91637	MFF1816D50000C
R304	321-0193-03			RES., FXD, FILM: 1K OHM, 0.25%, 0.125W	91637	MFF1816D10000C
R305	321-0256-00			RES., FXD, FILM: 4.53K OHM, 1%, 0.125W	91637	MFF1816G45300F
R308	321-0278-00			RES., FXD, FILM: 7.68K OHM, 1%, 0.125W	91637	MFF1816G76800F
R310	321-0231-00			RES., FXD, FILM: 2.49K OHM, 1%, 0.125W	91637	MFF1816G24900F
R311	315-0101-00			RES., FXD, CMPSN: 100 OHM, 5%, 0.25W	01121	CB1015
R313	321-0816-03			RES., FXD, FILM: 5K OHM, 0.25%, 0.125W	91637	MFF1816D50000C
R314	321-0193-03			RES., FXD, FILM: 1K OHM, 0.25%, 0.125W	91637	MFF1816D10000C
R315	321-0256-00			RES., FXD, FILM: 4.53K OHM, 1%, 0.125W	91637	MFF1816G45300F
R318	321-0278-00			RES., FXD, FILM: 7.68K OHM, 1%, 0.125W	91637	MFF1816G76800F
R320	321-0231-00			RES., FXD, FILM: 2.49K OHM, 1%, 0.125W	91637	MFF1816G24900F
R325	311-1567-00			RES., VAR, NONWIR: TRMR, 100 OHM, 0.50W	73138	91-89-0
R328	321-0933-03			RES., FXD, FILM: 6.66K OHM, 0.25%, 0.125W	91637	MFF1816D66600C
R329	321-0932-03			RES., FXD, FILM: 2.5K OHM, 0.25%, 0.125W	91637	MFF1816D25000C
R330	321-0931-03			RES., FXD, FILM: 1.11K OHM, 0.25%, 0.125W	91637	MFF1816D11100C
R331	321-0660-03			RES., FXD, FILM: 417 OHM, 0.25%, 0.125W	91637	MFF1816D417R0C
R332	321-0930-03			RES., FXD, FILM: 204 OHM, 0.25%, 0.125W	91637	MFF1816D204R0C
R333	321-1097-03			RES., FXD, FILM: 101 OHM, 0.25%, 0.125W	91637	MFF1816D101R0C
R334	321-0030-03			RES., FXD, FILM: 20.0 OHM, 0.25%, 0.125W	91637	MFF1816D20R00C
R336	321-0030-03			RES., FXD, FILM: 20.0 OHM, 0.25%, 0.125W	91637	MFF1816D20R00C
R343	315-0203-00			RES., FXD, CMPSN: 20K OHM, 5%, 0.25W	01121	CB2035
R344	315-0331-00			RES., FXD, CMPSN: 330 OHM, 5%, 0.25W	01121	CB3315
R346	315-0203-00			RES., FXD, CMPSN: 20K OHM, 5%, 0.25W	01121	CB2035
R347	321-0222-00			RES., FXD, FILM: 2K OHM, 1%, 0.125W	91637	MFF1816G20000F
R348	315-0331-00			RES., FXD, CMPSN: 330 OHM, 5%, 0.25W	01121	CB3315
R353	315-0203-00			RES., FXD, CMPSN: 20K OHM, 5%, 0.25W	01121	CB2035

Replaceable Electrical Parts—5A26

Ckt No.	Tektronix Part No.	Serial/Model No. Eff	Dscont	Name & Description	Mfr Code	Mfr Part Number
R354	315-0331-00			RES., FXD, CMPSN: 330 OHM, 5%, 0.25W	01121	CB3315
R358	315-0331-00			RES., FXD, CMPSN: 330 OHM, 5%, 0.25W	01121	CB3315
R359	321-0228-00			RES., FXD, FILM: 2.32K OHM, 1%, 0.125W	91637	MFF1816G23200F
R362	321-0286-00			RES., FXD, FILM: 9.31K OHM, 1%, 0.125W	91637	MFF1816G93100F
R363	321-0215-00			RES., FXD, FILM: 1.69K OHM, 1%, 0.125W	91637	MFF1816G16900F
R364	311-1403-00			RES., VAR, NONWIR: 5K OHM, 20%, 0.50W (FURNISHED AS A UNIT WITH S528)	01121	10M922
R365	321-0260-00			RES., FXD, FILM: 4.99K OHM, 1%, 0.125W	91637	MFF1816G49900F
R366	321-0193-00			RES., FXD, FILM: 1K OHM, 1%, 0.125W	91637	MFF1816G10000F
R368	321-0324-00			RES., FXD, FILM: 23.2K OHM, 1%, 0.125W	91637	MFF1816G23201F
R372	321-0286-00			RES., FXD, FILM: 9.31K OHM, 1%, 0.125W	91637	MFF1816G93100F
R373	311-1565-00			RES., VAR, NONWIR: 250 OHM, 20%, 0.50W	73138	91A R250
R374	311-0546-00			RES., VAR, NONWIR: 10K OHM, 20%, 0.75W	80009	311-0546-00
R375	321-0323-00			RES., FXD, FILM: 22.6K OHM, 1%, 0.125W	91637	MFF1816G22601F
R376	321-0193-00			RES., FXD, FILM: 1K OHM, 1%, 0.125W	91637	MFF1816G10000F
R378	321-0324-00			RES., FXD, FILM: 23.2K OHM, 1%, 0.125W	91637	MFF1816G23201F
R379	315-0122-00			RES., FXD, CMPSN: 1.2K OHM, 5%, 0.25W	01121	CB1225
R380	315-0470-00			RES., FXD, CMPSN: 47 OHM, 5%, 0.25W	01121	CB4705
R382	321-0247-00			RES., FXD, FILM: 3.65K OHM, 1%, 0.125W	91637	MFF1816G36500F
R384	321-0159-00			RES., FXD, FILM: 442 OHM, 1%, 0.125W	91637	MFF1816G442ROF
R386	315-0153-00			RES., FXD, CMPSN: 15K OHM, 5%, 0.25W	01121	CB1535
R387	321-0356-00			RES., FXD, FILM: 49.9K OHM, 1%, 0.125W	91637	MFF1816G49901F
R389	321-0362-00			RES., FXD, FILM: 57.6K OHM, 1%, 0.125W	91637	MFF1816G57601F
R390	315-0470-00			RES., FXD, CMPSN: 47 OHM, 5%, 0.25W	01121	CB4705
R392	321-0247-00			RES., FXD, FILM: 3.65K OHM, 1%, 0.125W	91637	MFF1816G36500F
R402	321-0159-00			RES., FXD, FILM: 442 OHM, 1%, 0.125W	91637	MFF1816G442ROF
R402	315-0104-00			RES., FXD, CMPSN: 100K OHM, 5%, 0.25W	01121	CB1045
R403	315-0101-00			RES., FXD, CMPSN: 100 OHM, 5%, 0.25W	01121	CB1015
R405	315-0103-00			RES., FXD, CMPSN: 10K OHM, 5%, 0.25W	01121	CB1035
R406	315-0181-00			RES., FXD, CMPSN: 180 OHM, 5%, 0.25W	01121	CB1815
R407	315-0101-00			RES., FXD, CMPSN: 100 OHM, 5%, 0.25W	01121	CB1015
R409	315-0223-00	XB020000		RES., FXD, CMPSN: 22K OHM, 5%, 0.25W	01121	CB2235
R410	321-0264-00	B010100	B019999	RES., FXD, FILM: 5.49K OHM, 1%, 0.125W	91637	MFF1816G54900F
R410	315-0101-00	B020000		RES., FXD, CMPSN: 100 OHM, 5%, 0.25W	01121	CB1015
R411	322-0264-00	B010100	B019999	RES., FXD, FILM: 5.49K OHM, 1%, 0.25W	75042	CEBT0-5491F
R411	321-0222-00	B020000		RES., FXD, FILM: 2K OHM, 1%, 0.125W	91637	MFF1816G20000F
R413	321-0264-00	B010100	B019999	RES., FXD, FILM: 5.49K OHM, 1%, 0.125W	91637	MFF1816G54900F
R413	315-0101-00	B020000		RES., FXD, CMPSN: 100 OHM, 5%, 0.25W	01121	CB1015
R414	322-0264-00	B010100	B019999	RES., FXD, FILM: 5.49K OHM, 1%, 0.25W	75042	CEBT0-5491F
R414	321-0222-00	B020000		RES., FXD, FILM: 2K OHM, 1%, 0.125W	91637	MFF1816G20000F
R415	315-0105-00	XB020000		RES., FXD, CMPSN: 1M OHM, 5%, 0.25W	01121	CB1055
R416	315-0473-00	B010100	B019999	RES., FXD, CMPSN: 47K OHM, 5%, 0.25W	01121	CB4735
R416	315-0224-00	B020000		RES., FXD, CMPSN: 220K OHM, 5%, 0.25W	01121	CB2245
R417	315-0154-00	XB020000		RES., FXD, CMPSN: 150K OHM, 5%, 0.25W	01121	CB1545
R418	315-0105-00	B010100	B019999	RES., FXD, CMPSN: 1M OHM, 5%, 0.25W	01121	CB1055
R418	315-0431-00	B020000		RES., FXD, CMPSN: 430 OHM, 5%, 0.25W	01121	CB4315
R419	315-0105-00	B010100	B019999	RES., FXD, CMPSN: 1M OHM, 5%, 0.25W	01121	CB1055
R419	315-0154-00	B020000		RES., FXD, CMPSN: 150K OHM, 5%, 0.25W	01121	CB1545
R421	315-0431-00	XB020000		RES., FXD, CMPSN: 430 OHM, 5%, 0.25W	01121	CB4315
R423	301-0124-00	B010100	B019999	RES., FXD, CMPSN: 120K OHM, 5%, 0.50W	01121	EB1245
R423	315-0100-00	B020000		RES., FXD, CMPSN: 10 OHM, 5%, 0.25W	01121	CB1005
R426	321-0293-00	B010100	B019999	RES., FXD, FILM: 11K OHM, 1%, 0.125W	91637	MFF1816G11001F
R426	321-0289-00	B020000		RES., FXD, FILM: 10K OHM, 1%, 0.125W	91637	MFF1816G10001F
R427	321-0289-00	B010100	B019999	RES., FXD, FILM: 10K OHM, 1%, 0.125W	91637	MFF1816G10001F
R427	321-0287-00	B020000		RES., FXD, FILM: 9.53K OHM, 1%, 0.125W	91637	MFF1816G95300F
R429	315-0223-00	XB020000		RES., FXD, CMPSN: 22K OHM, 5%, 0.25W	01121	CB2235
R430	321-0264-00	B010100	B019999	RES., FXD, FILM: 5.49K OHM, 1%, 0.125W	91637	MFF1816G54900F

Ckt No.	Tektronix Part No.	Serial/Model No. Eff	Dscont	Name & Description	Mfr Code	Mfr Part Number
R430	315-0101-00	B020000		RES., FXD, CMPSN: 100 OHM, 5%, 0.25W	01121	CB1015
R431	322-0264-00	B010100	B019999	RES., FXD, FILM: 5.49K OHM, 1%, 0.25W	75042	CEBTO-5491F
R431	321-0222-00	B020000		RES., FXD, FILM: 2K OHM, 1%, 0.125W	91637	MFF1816G20000F
R433	321-0264-00	B010100	B019999	RES., FXD, FILM: 5.49K OHM, 1%, 0.125W	91637	MFF1816G54900F
R433	315-0101-00	B020000		RES., FXD, CMPSN: 100 OHM, 5%, 0.25W	01121	CB1015
R434	322-0264-00	B010100	B019999	RES., FXD, FILM: 5.49K OHM, 1%, 0.25W	75042	CEBTO-5491F
R434	321-0222-00	B020000		RES., FXD, FILM: 2K OHM, 1%, 0.125W	91637	MFF1816G20000F
R435	315-0105-00	XB020000		RES., FXD, CMPSN: 1M OHM, 5%, 0.25W	01121	CB1055
R436	315-0473-00	B010100	B019999	RES., FXD, CMPSN: 47K OHM, 5%, 0.25W	01121	CB4735
R436	315-0224-00	B020000		RES., FXD, CMPSN: 220K OHM, 5%, 0.25W	01121	CB2245
R437	315-0154-00	XB020000		RES., FXD, CMPSN: 150K OHM, 5%, 0.25W	01121	CB1545
R438	315-0105-00	B010100	B019999	RES., FXD, CMPSN: 1M OHM, 5%, 0.25W	01121	CB1055
R438	315-0431-00	B020000		RES., FXD, CMPSN: 430 OHM, 5%, 0.25W	01121	CB4315
R439	315-0105-00	B010100	019999	RES., FXD, CMPSN: 1M OHM, 5%, 0.25W	01121	CB1055
R439	315-0154-00	B020000		RES., FXD, CMPSN: 150K OHM, 5%, 0.25W	01121	CB1545
R441	315-0431-00	XB020000		RES., FXD, CMPSN: 430 OHM, 5%, 0.25W	01121	CB4315
R443	301-0124-00	B010100	B019999	RES., FXD, CMPSN: 120K OHM, 5%, 0.50W	01121	EB1245
R443	315-0100-00	B020000		RES., FXD, CMPSN: 10 OHM, 5%, 0.25W	01121	CB1005
R444	315-0274-00	XB040000		RES., FXD, CMPSN: 270K OHM, 5%, 0.25W	01121	CB2745
R445	301-0103-00	B010100	B019999X	RES., FXD, CMPSN: 10K OHM, 5%, 0.50W	01121	EB1035
R451	321-0299-00			RES., FXD, FILM: 12.7K OHM, 1%, 0.125W	91637	MFF1816G12701F
R454	321-0398-00			RES., FXD, FILM: 137K OHM, 1%, 0.125W	91637	MFF1816G13702F
R455	321-0374-00			RES., FXD, FILM: 76.8K OHM, 1%, 0.125W	91637	MFF1816G76801F
R456	321-0385-00			RES., FXD, FILM: 100K OHM, 1%, 0.125W	91637	MFF1816G10002F
R457	321-0379-00			RES., FXD, FILM: 86.6K OHM, 1%, 0.125W	91637	MFF1816G86601F
R459	315-0203-00			RES., FXD, CMPSN: 20K OHM, 5%, 0.25W	01121	CB2035
R460	315-0753-00			RES., FXD, CMPSN: 75K OHM, 5%, 0.25W	01121	CB7535
R462	321-0281-00			RES., FXD, FILM: 8.25K OHM, 1%, 0.125W	91637	MFF1816G82500F
R463	321-0397-00			RES., FXD, FILM: 133K OHM, 1%, 0.125W	91637	MFF1816G13302F
R464	321-0356-00			RES., FXD, FILM: 49.9K OHM, 1%, 0.125W	91637	MFF1816G49901F
R465	321-0385-00			RES., FXD, FILM: 100K OHM, 1%, 0.125W	91637	MFF1816G10002F
R467	315-0203-00			RES., FXD, CMPSN: 20K OHM, 5%, 0.25W	01121	CB2035
R470	321-0374-00			RES., FXD, FILM: 76.8K OHM, 1%, 0.125W	91637	MFF1816G76801F
R471	321-0398-00			RES., FXD, FILM: 137K OHM, 1%, 0.125W	91637	MFF1816G13702F
R472	321-0385-00			RES., FXD, FILM: 100K OHM, 1%, 0.125W	91637	MFF1816G10002F
R473	321-0379-00			RES., FXD, FILM: 86.6K OHM, 1%, 0.125W	91637	MFF1816G86601F
R475	315-0203-00			RES., FXD, CMPSN: 20K OHM, 5%, 0.25W	01121	CB2035
R476	315-0513-00			RES., FXD, CMPSN: 51K OHM, 5%, 0.25W	01121	CB5135
R478	315-0123-00			RES., FXD, CMPSN: 12K OHM, 5%, 0.25W	01121	CB1235
R479	315-0154-00			RES., FXD, CMPSN: 150K OHM, 5%, 0.25W	01121	CB1545
R481	315-0753-00			RES., FXD, CMPSN: 75K OHM, 5%, 0.25W	01121	CB7535
R482	321-0344-00			RES., FXD, FILM: 37.4K OHM, 1%, 0.125W	91637	MFF1816G37401F
R484	315-0103-00			RES., FXD, CMPSN: 10K OHM, 5%, 0.25W	01121	CB1035
R485	315-0103-00			RES., FXD, CMPSN: 10K OHM, 5%, 0.25W	01121	CB1035
R501	321-0299-00			RES., FXD, FILM: 12.7K OHM, 1%, 0.125W	91637	MFF1816G12701F
R504	321-0398-00			RES., FXD, FILM: 137K OHM, 1%, 0.125W	91637	MFF1816G13702F
R505	321-0374-00			RES., FXD, FILM: 76.8K OHM, 1%, 0.125W	91637	MFF1816G76801F
R506	321-0385-00			RES., FXD, FILM: 100K OHM, 1%, 0.125W	91637	MFF1816G10002F
R507	321-0379-00			RES., FXD, FILM: 86.6K OHM, 1%, 0.125W	91637	MFF1816G86601F
R509	315-0203-00			RES., FXD, CMPSN: 20K OHM, 5%, 0.25W	01121	CB2035
R510	315-0753-00			RES., FXD, CMPSN: 75K OHM, 5%, 0.25W	01121	CB7535
R512	321-0281-00			RES., FXD, FILM: 8.25K OHM, 1%, 0.125W	91637	MFF1816G82500F
R513	321-0397-00			RES., FXD, FILM: 133K OHM, 1%, 0.125W	91637	MFF1816G13302F
R514	321-0356-00			RES., FXD, FILM: 49.9K OHM, 1%, 0.125W	91637	MFF1816G49901F
R515	321-0385-00			RES., FXD, FILM: 100K OHM, 1%, 0.125W	91637	MFF1816G10002F
R517	315-0203-00			RES., FXD, CMPSN: 20K OHM, 5%, 0.25W	01121	CB2035
R520	321-0374-00			RES., FXD, FILM: 76.8K OHM, 1%, 0.125W	91637	MFF1816G76801F

Replaceable Electrical Parts—5A26

Ckt No.	Tektronix Part No.	Serial/Model No. Eff	Dscont	Name & Description	Mfr Code	Mfr Part Number
R521	321-0398-00			RES., FXD, FILM: 137K OHM, 1%, 0.125W	91637	MFF1816G13702F
R522	321-0385-00			RES., FXD, FILM: 100K OHM, 1%, 0.125W	91637	MFF1816G10002F
R523	321-0379-00			RES., FXD, FILM: 86.6K OHM, 1%, 0.125W	91637	MFF1816G86601F
R525	315-0203-00			RES., FXD, CMPSN: 20K OHM, 5%, 0.25W	01121	CB2035
R526	315-0513-00			RES., FXD, CMPSN: 51K OHM, 5%, 0.25W	01121	CB5135
R528	315-0123-00			RES., FXD, CMPSN: 12K OHM, 5%, 0.25W	01121	CB1235
R529	315-0154-00			RES., FXD, CMPSN: 150K OHM, 5%, 0.25W	01121	CB1545
R531	315-0753-00			RES., FXD, CMPSN: 75K OHM, 5%, 0.25W	01121	CB7535
R532	321-0344-00			RES., FXD, FILM: 37.4K OHM, 1%, 0.125W	91637	MFF1816G37401F
S2	260-1774-00			SWITCH, PUSH: 4 BUTTON, DPDT	80009	260-1774-00
S20	263-1131-00			ACTR ASSY, CAM S:	80009	263-1131-00
S102	260-1774-00			SWITCH, PUSH: 4 BUTTON, DPDT	80009	260-1774-00
S120	263-1131-00			ACTR ASSY, CAM S:	80009	263-1131-00
S239	260-1445-00			SWITCH, PUSH: 1 STA, NON-SHORT	80009	260-1445-00
S289	260-1773-00			SWITCH, PUSH: 2 BUTTON 4PDT	80009	260-1773-00
S339	260-1445-00			SWITCH, PUSH: 1 STA, NON-SHORT	80009	260-1445-00
S401	260-1211-00			SWITCH, PUSH: 1A, 28VDC	80009	260-1211-00
S445	260-1209-00			SWITCH, PUSH: 4PDT, 1A, 25VDC	80009	260-1209-00
S478	311-1403-00			RES., VAR, NONWIR: 5K OHM, 20%, 0.50W (FURNISHED AS A UNIT WITH R264)	01121	10M922
S528	311-1403-00			RES., VAR, NONWIR: 5K OHM, 20%, 0.50W (FURNISHED AS A UNIT WITH R364)	01121	10M922
VR23	152-0168-00			SEMICONV DEVICE: ZENER, 0.4W, 12V, 5%	80009	152-0168-00
VR25	152-0168-00			SEMICONV DEVICE: ZENER, 0.4W, 12V, 5%	80009	152-0168-00
VR40	152-0227-00			SEMICONV DEVICE: ZENER, 0.4W, 6.2V, 5%	80009	152-0227-00
VR42	152-0227-00			SEMICONV DEVICE: ZENER, 0.4W, 6.2V, 5%	80009	152-0227-00
VR97	152-0168-00			SEMICONV DEVICE: ZENER, 0.4W, 12V, 5%	80009	152-0168-00
VR123	152-0168-00			SEMICONV DEVICE: ZENER, 0.4W, 12V, 5%	80009	152-0168-00
VR125	152-0168-00			SEMICONV DEVICE: ZENER, 0.4W, 12V, 5%	80009	152-0168-00
VR140	152-0227-00			SEMICONV DEVICE: ZENER, 0.4W, 6.2V, 5%	80009	152-0227-00
VR142	152-0227-00			SEMICONV DEVICE: ZENER, 0.4W, 6.2V, 5%	80009	152-0227-00
VR197	152-0168-00			SEMICONV DEVICE: ZENER, 0.4W, 12V, 5%	80009	152-0168-00
VR222	153-0030-00			SEMICONV DVC SE: MTCHD WITHIN 0.1V AT 0.4W, MW	80009	153-0030-00
VR224	152-0227-00			SEMICONV DEVICE: ZENER, 0.4W, 6.2V, 5%	80009	152-0227-00
VR296	152-0149-00			SEMICONV DEVICE: ZENER, 0.4W, 10V, 5%	80009	152-0149-00
VR322	153-0030-00			SEMICONV DVC SE: MTCHD WITHIN 0.1V AT 0.4W, MW	80009	153-0030-00
VR324	152-0227-00	B010100	B010169X	SEMICONV DEVICE: ZENER, 0.4W, 6.2V, 5%	80009	152-0227-00

SERVICE INFORMATION

SERVICES AVAILABLE

Tektronix, Inc. provides complete instrument repair and adjustment at local Field Service Centers and at the Factory Service Center. Contact your local Tektronix Field Office or Representative for further information.

MAINTENANCE

General system maintenance procedures are provided in the 5000-series Oscilloscope instruction manual.

Circuit Board Removal

PREAMPLIFIER BOARDS. The Channel 1 and Channel 2 Preamplifier boards are identical. Therefore, the following procedure applies to either board.

1. Remove left and right side covers from 5A26.
2. Remove one attaching screw at rear and four in center of board.
3. Unsolder ground wire between Input Coupling switches and shield.
4. Remove multi-pin connector near outside front edge of Main board (right side of 5A26).
5. Gently pull out leads from rear of + and - input connectors (right side of 5A26).
6. Loosen set screws that attach POS control shaft to flexible coupler and remove shaft.
7. Slide Preamplifier board back from front panel to free Input Coupling buttons.

NOTE

Preamplifier board will lift away with ribbon cable attached to gain access to the bottom of the Main board or back of Preamplifier board. To completely remove Preamplifier board, unsolder ribbon cable.

MAIN BOARD. Remove Main board as follows:

1. Remove both Preamplifier boards as described in preceding procedure.
2. Loosen set screws that attach VOLTS/DIV knobs to shaft and remove knobs.
3. Remove remaining two mounting screws located on each side and toward front of Main board.
4. Unsolder leads between input connector probe-coding rings and Main board.
5. Slide VOLTS/DIV X1 and X10 indicator lights away from front panel.
6. Gently slide Main board back to free buttons and STEP ATTEN BAL control shafts from front panel.

ADJUSTMENTS AFTER REPAIR

If any electrical components are replaced, the adjustments for the affected channel should be checked. Refer to the Adjustment Procedure in this section.

DIAGRAMS AND CIRCUIT BOARD ILLUSTRATIONS

Symbols and Reference Designators

Electrical components shown on the diagrams are in the following units unless noted otherwise:

- Capacitors = Values one or greater are in picofarads (pF).
Values less than one are in microfarads (μF).
- Resistors = Ohms (Ω).

Graphic symbols and class designation letters are based on ANSI Standard Y32.2-1975.

Logic symbology is based on ANSI Y32.14-1973 in terms of positive logic. Logic symbols depict the logic function performed and may differ from the manufacturer's data.

The overline on a signal name indicates that the signal performs its intended function when it goes to the low state.

Abbreviations are based on ANSI Y1.1-1972.

Other ANSI standards that are used in the preparation of diagrams by Tektronix, Inc. are:

- Y14.15, 1966 Drafting Practices.
- Y14.2, 1973 Line Conventions and Lettering.
- Y10.5, 1968 Letter Symbols for Quantities Used in Electrical Science and Electrical Engineering.

The following prefix letters are used as reference designators to identify components or assemblies on the diagrams.

A	Assembly, separable or repairable (circuit board, etc)	H	Heat dissipating device (heat sink, heat radiator, etc)	S	Switch or contactor
AT	Attenuator, fixed or variable	HR	Heater	T	Transformer
B	Motor	HY	Hybrid circuit	TC	Thermocouple
BT	Battery	J	Connector, stationary portion	TP	Test point
C	Capacitor, fixed or variable	K	Relay	U	Assembly, inseparable or non-repairable (integrated circuit, etc.)
CB	Circuit breaker	L	Inductor, fixed or variable	V	Electron tube
CR	Diode, signal or rectifier	M	Meter	VR	Voltage regulator (zener diode, etc.)
DL	Delay line	P	Connector, movable portion	W	Wirestrap or cable
DS	Indicating device (lamp)	Q	Transistor or silicon-controlled rectifier	Y	Crystal
E	Spark Gap, Ferrite bead	R	Resistor, fixed or variable	Z	Phase shifter
F	Fuse	RT	Thermistor		
FL	Filter				

The following special symbols may appear on the diagrams:

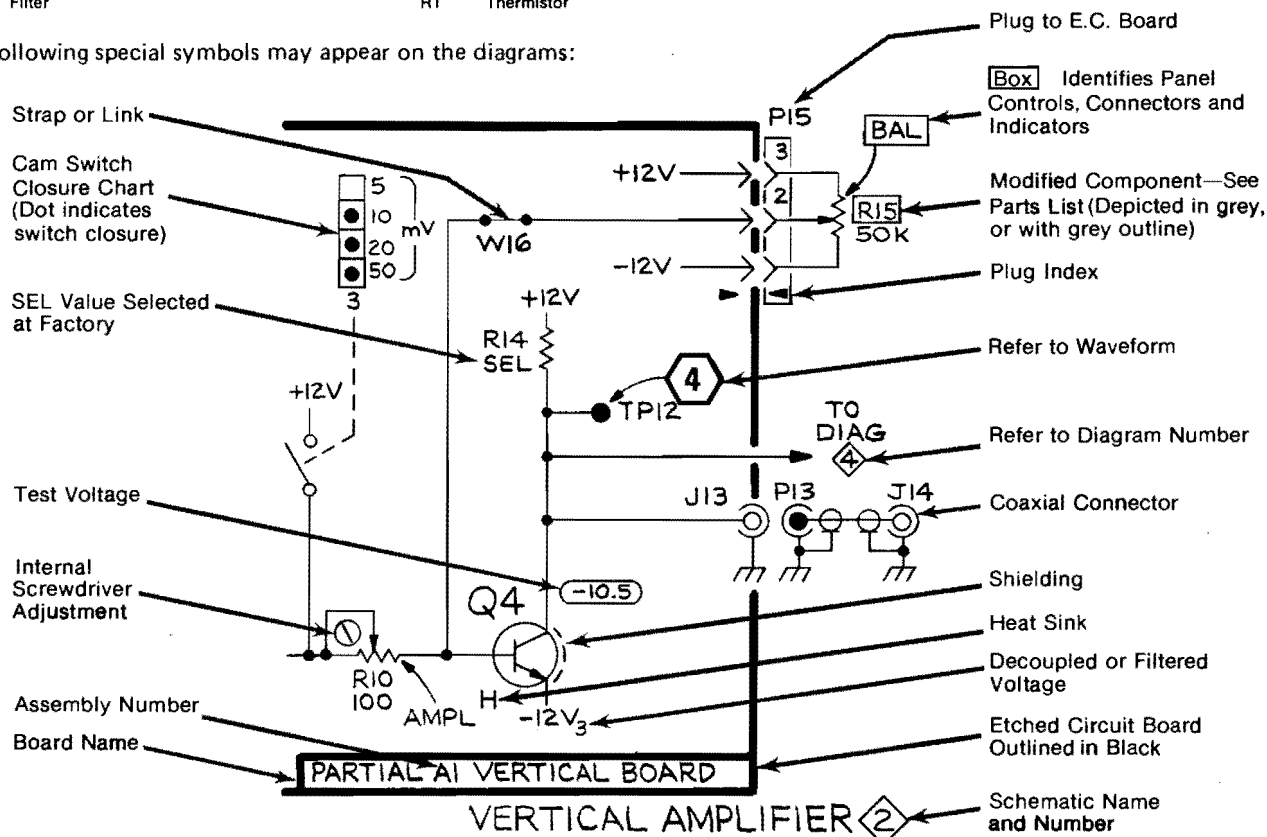

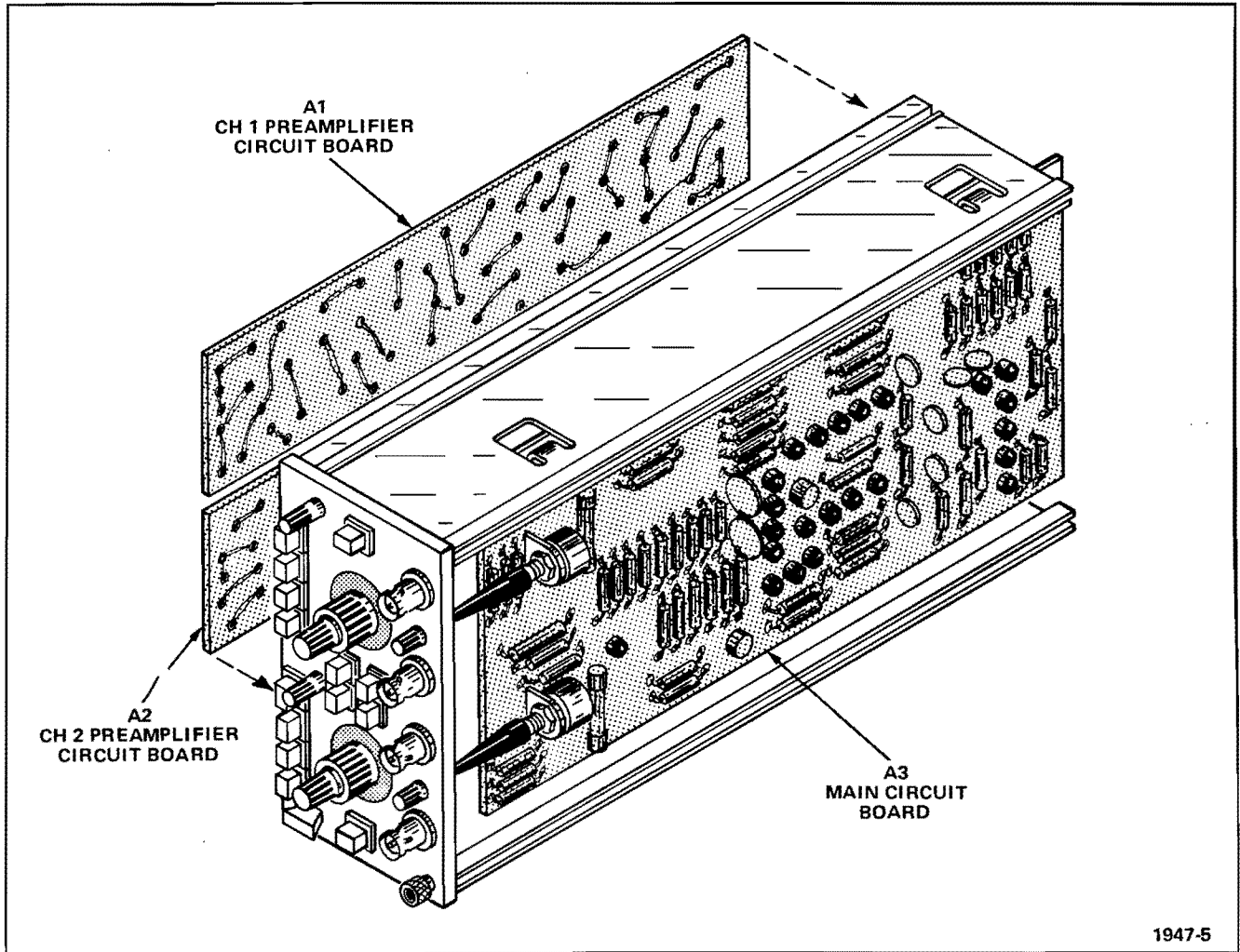
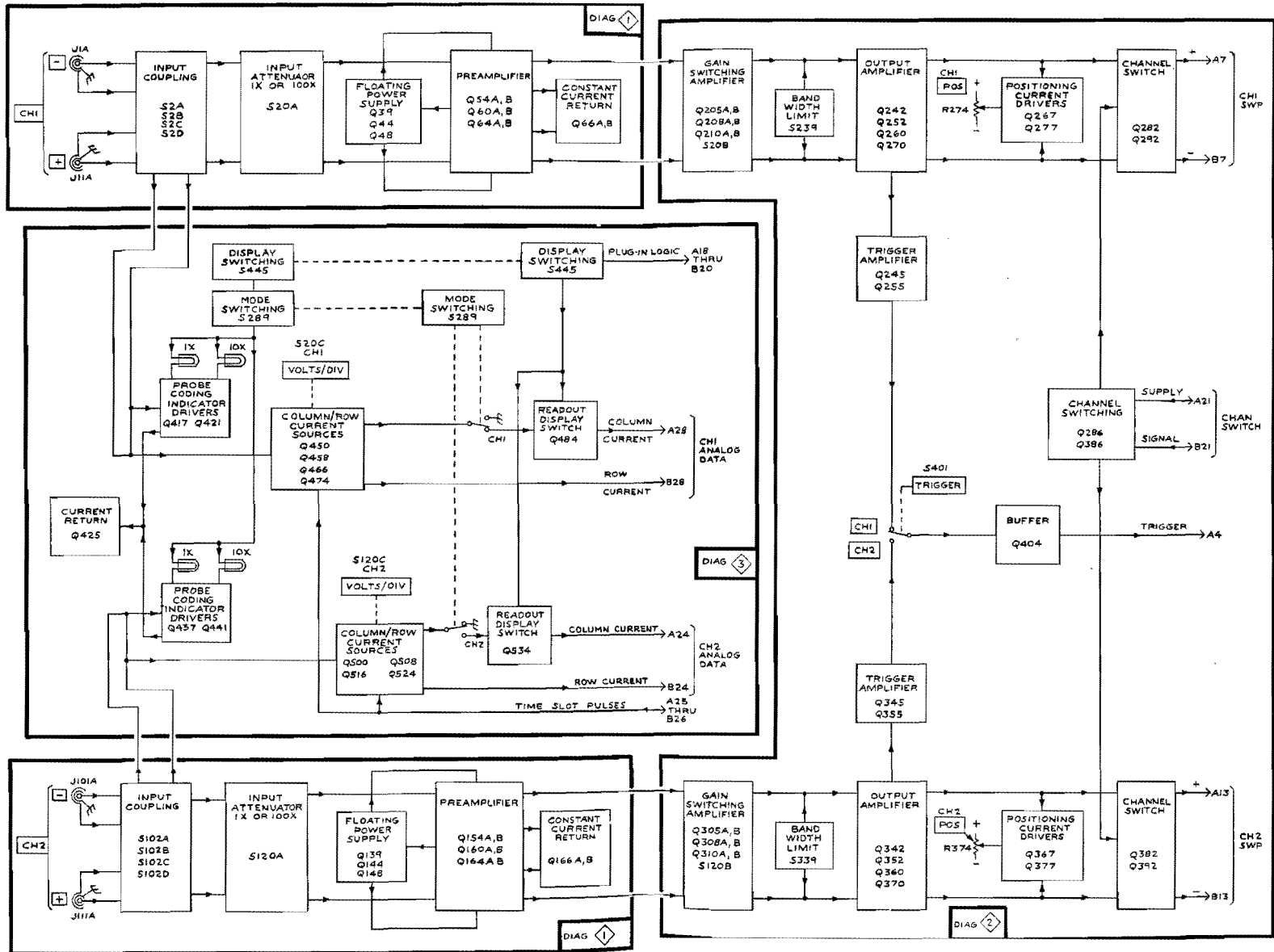

Fig. 4-1. Circuit board locations.



5A26

1947-20
REV A, NOV 1978

BLOCK DIAGRAM
REDUCED FROM ORIGINAL

ADJUSTMENT PROCEDURE

TEST EQUIPMENT

The following test equipment and accessories, or their equivalents, are required for complete calibration of the 5A26. Specifications given for the test equipment are the minimum necessary for accurate calibration. Therefore, some of the specifications listed here may be somewhat less rigorous than the actual performance capabilities of the test equipment. All test equipment is assumed to be correctly calibrated and operating within the listed specifications.

The Adjustment Procedure is based on this recommended equipment. If other equipment is substituted, control settings or calibration setup may need to be altered to meet the requirements of the equipment used. Detailed operating instructions for the test equipment are not given in this procedure. Refer to the instruction manual for the test equipment if more information is needed.

1. Oscilloscope—TEKTRONIX 5400-series oscilloscope.
2. Time base plug-in unit—TEKTRONIX 5B10N Time Base/Amplifier.
3. Sine-wave generator—TEKTRONIX FG 503 Function Generator (operates in a TEKTRONIX TM 500-series power module).
4. Square-wave generator—TEKTRONIX FG 503 Function Generator (operates in a TEKTRONIX TM 500-series power module).
5. Standard amplitude calibrator—TEKTRONIX PG 506 (operates in a TEKTRONIX TM 500-series power module).
6. 47 pF normalizer—Tektronix part 067-0541-00.
7. Plug-in extension cable for 5400-series oscilloscopes—Tektronix part 067-0645-03.
8. Dual input connector—Tektronix part 067-0525-01.
9. 50 Ω BNC coaxial cable—Tektronix part 012-0057-01.

PROCEDURE

Preparation

The 5A26 should be adjusted at an ambient temperature between +20°C and +30°C (+68°F and +86°F) for best accuracy. Connect the 5A26 to the oscilloscope with the plug-in extension cable. Remove the plug-in side covers. Allow at least 15 minutes for warmup. Refer to Fig. 4-1, Circuit Board Locations and Fig. 4-3, Adjustment Locations.

Control Settings

5A26 (both channels)

POS	Midrange
VOLTS/DIV	50 m
CAL (Variable VOLTS/DIV)	Fully clockwise (detent)
STEP ATTEN BAL	Midrange
DISPLAY	ON (button in)
MODE	CH 1 and CH 2 (buttons in)
BW LIMIT	OUT: 1 MHz (button out)
TRIGGER	OUT: CH 1 (button out)
+ Input Coupling	
AC	OUT: DC (button out)
GND	GND (button in)
- Input Coupling	
AC	OUT: DC (button out)
GND	GND (button in)

Time Base

Time/Div (Calibrated)	0.2 millisecond
Position	Midrange
Display	Alternate
Triggering Mode	Auto, triggered, ac coupling, + slope
Triggering Source	Left
Triggering Level	Midrange

1. ADJUST VARIABLE BALANCE

- a. Position CH 1 trace 2 divisions above graticule center and CH 2 trace 2 divisions below graticule center.
- b. Adjust Var Bal 1, R225, for no trace shift as CH 1 CAL (Variable VOLTS/DIV) control is rotated throughout its range.
- c. Repeat part (b) for Var Bal 2, R325, and CH 2 CAL (Variable VOLTS/DIV) control.
- d. Return CH 1 and CH 2 CAL (Variable VOLTS/DIV) controls to fully clockwise (calibrated) position.

2. ADJUST ATTENUATOR BALANCE RANGE

- a. Adjust CH 1 Atten Bal Range, R89, for no trace shift as CH 1 VOLTS/DIV switch is positioned from 50 m through 50 μ . (If necessary, slight adjustment of front-panel STEP ATTEN BAL control is permissible.)
- b. Repeat part (a) for CH 2 Atten Bal Range, R189, and CH 2 VOLTS/DIV switch.

g. Disconnect dual input connector and reconnect to CH 2 + and - inputs.

h. Set 5A26 controls as follows:

CH 1 + and - Input	
Coupling	
GND	GND (button in)
CH 2 + and - Input	
Coupling	
GND	Off (button out)
TRIGGER	CH 2 (button in)

i. Adjust CH 2 HF CMR, C159, for minimum display amplitude.

j. Set CH 2 VOLTS/DIV to .1.

k. Adjust Input Comp, C105 (5), for minimum display amplitude.

l. Disconnect dual input connector.

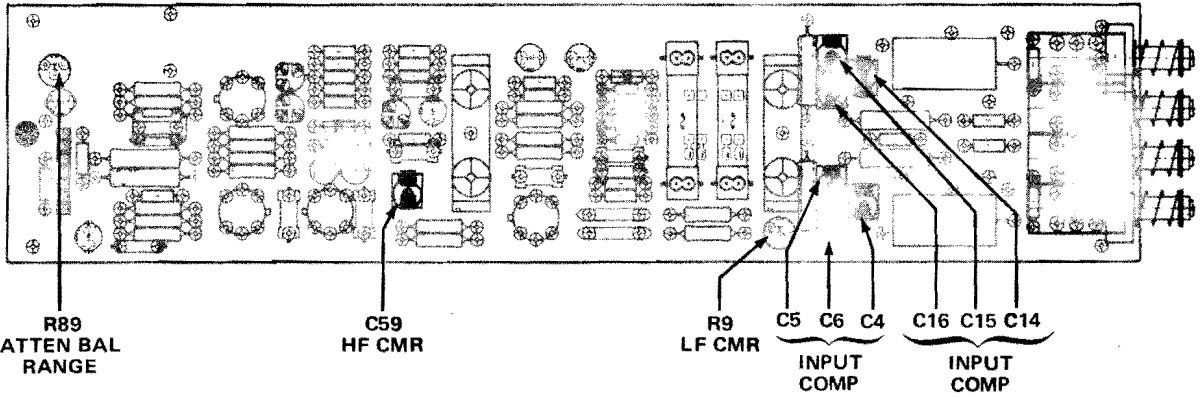

A2 - CH 2 PREAMPLIFIER CIRCUIT BOARD

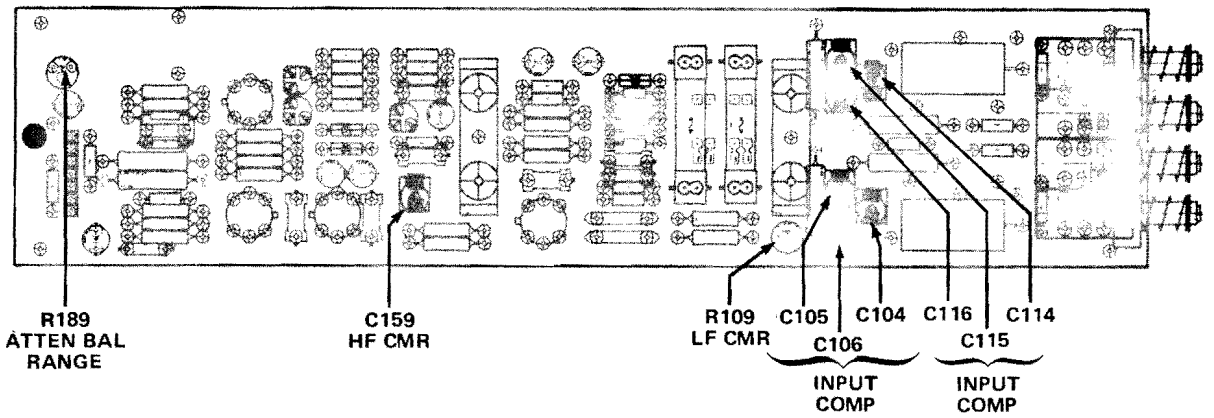

A3 - MAIN CIRCUIT BOARD

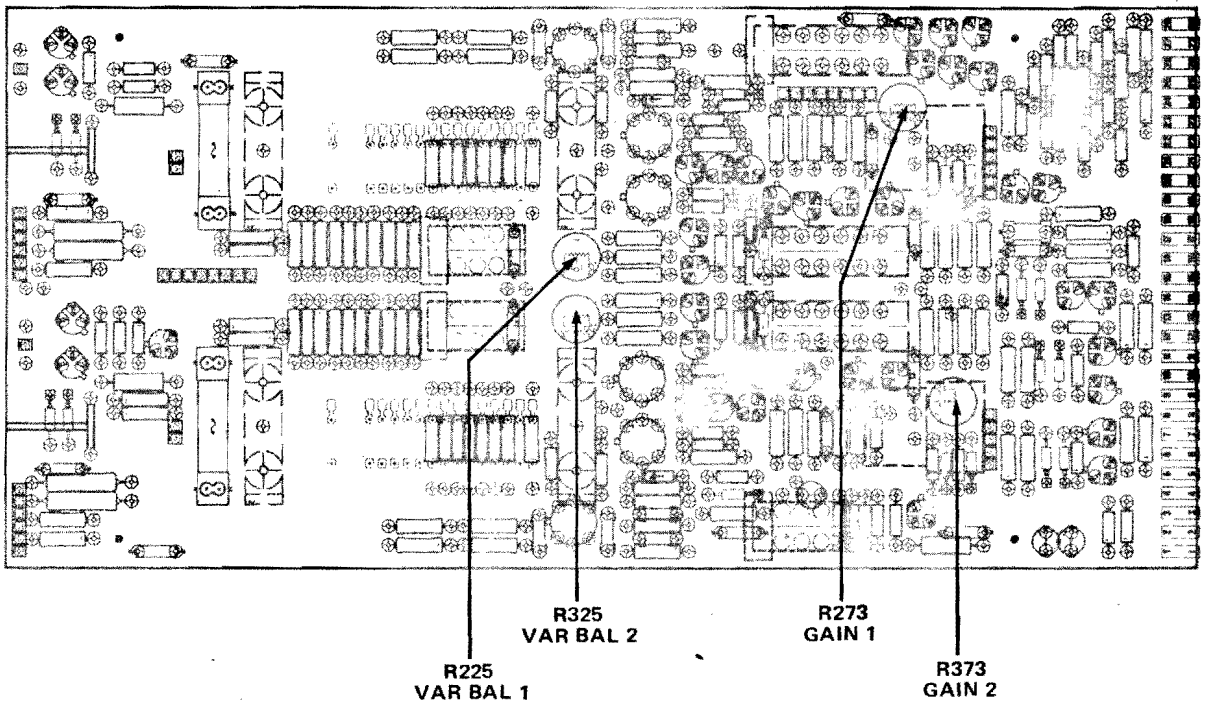

Fig. 4-3. Adjustment locations.

VOLTAGE AND WAVEFORM CONDITIONS

The voltages and waveforms shown on this diagram were obtained from a calibrated 5A26 with the following recommended test equipment set-up.

RECOMMENDED TEST EQUIPMENT

Item	Description	Recommended Type
Oscilloscope system	Deflection factor, 2 mV/div to 5 V/div. Input impedance, 1 M Ω . Frequency response, dc to 1 MHz.	Tektronix 5440 Oscilloscope with 5A15N Amplifier, P6062B 10X Probe, and 5B10N Time Base Amplifier.
Voltmeter (non-loading digital multimeter)	Input impedance, 10 M Ω . Dc voltage range, ± 2 V to ± 30 V (full scale).	Tektronix DM502 Digital Multimeter with TM 500-series Power Module.
Sine wave generator	Frequency range, 1 kHz. Output amplitude, 10 V p-p (0 dc offset).	Tektronix FG503 Function Generator with TM 500-series Power Module.
Plug-in extension cable	Capable of extending 5A26 from oscilloscope plug-in compartment.	Tektronix part no. 067-0645-03.

VOLTAGES

Dc voltages are measured with no signal applied. The voltmeter common is connected to chassis ground. The 5A26 is connected to the oscilloscope left vertical plug-in compartment through the plug-in extension cable and the controls are set as follows:

Control Settings

VOLTS/DIV **5**

+ Input Coupling

AC OUT:DC (button out)

GND GND (button in)

- Input Coupling

AC OUT:DC (button in)

GND GND (button in)

NOTE

The following control settings apply for either input of CH 1 or CH 2.

MODE CH 1 (button in)

BW LIMIT OUT: 1 MHz (button out)

DISPLAY ON (button in)

POS Position trace to center screen

Voltages are accurate to within 20%.

WAVEFORMS

The 5A26 is connected to the oscilloscope left vertical plug-in compartment through the plug-in extension cable. The amplifier plug-in is inserted in the right vertical oscilloscope plug-in compartment and the time-base plug-in is inserted in the extreme right oscilloscope plug-in compartment. A 1 kilohertz, 10 volt peak-to-peak sine wave is applied to the + or - input (single-ended). Waveforms are taken through the 10X probe and are accurate to within 20%.

Control Settings

VOLTS/DIV **2**

+ Input Coupling

AC OUT:DC (button out)

GND Off (button out)

- Input Coupling

AC OUT:DC (button in)

GND Off (button out)

Time Base

Sweep Rate 2 ms/div Mode Alternate

NOTE

The following control settings apply for either input of CH 1 or CH 2.

MODE CH 1 (button in)

TRIGGER OUT:CH 1 (button out)

BW LIMIT OUT:1 MHz (button out)

DISPLAY ON (button in)

POS Position trace to center screen

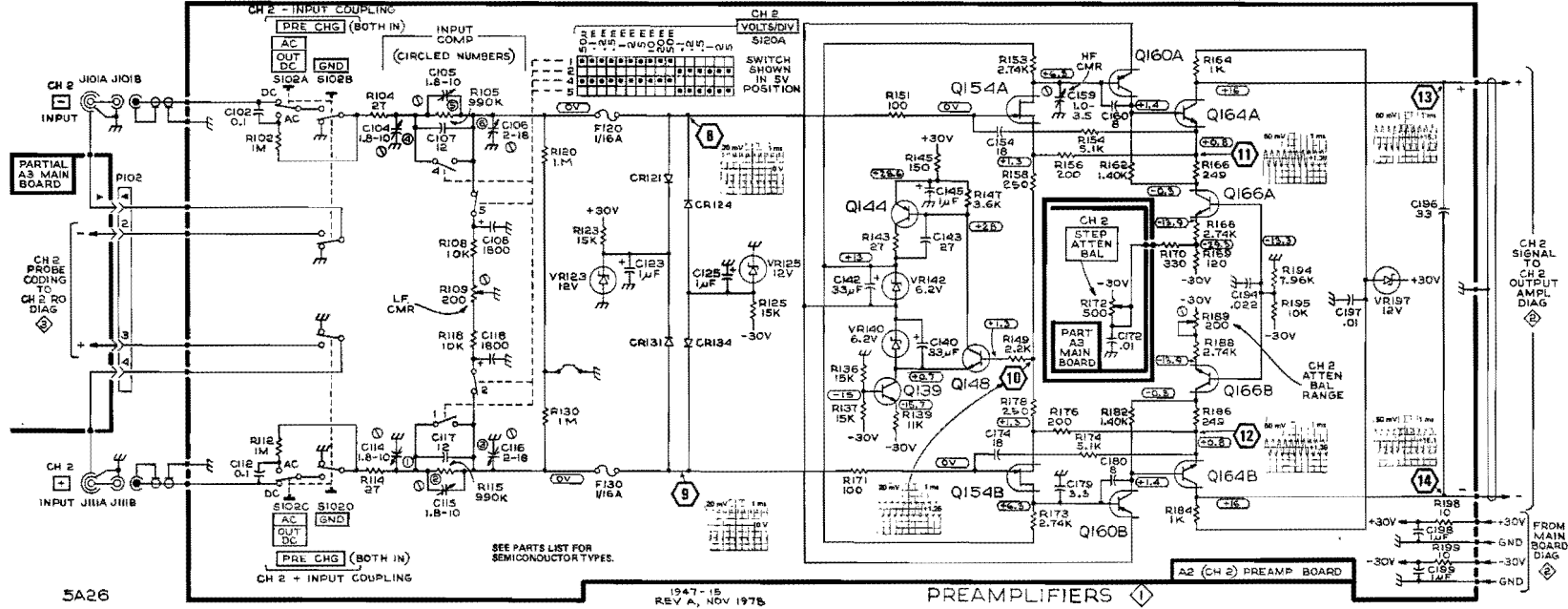
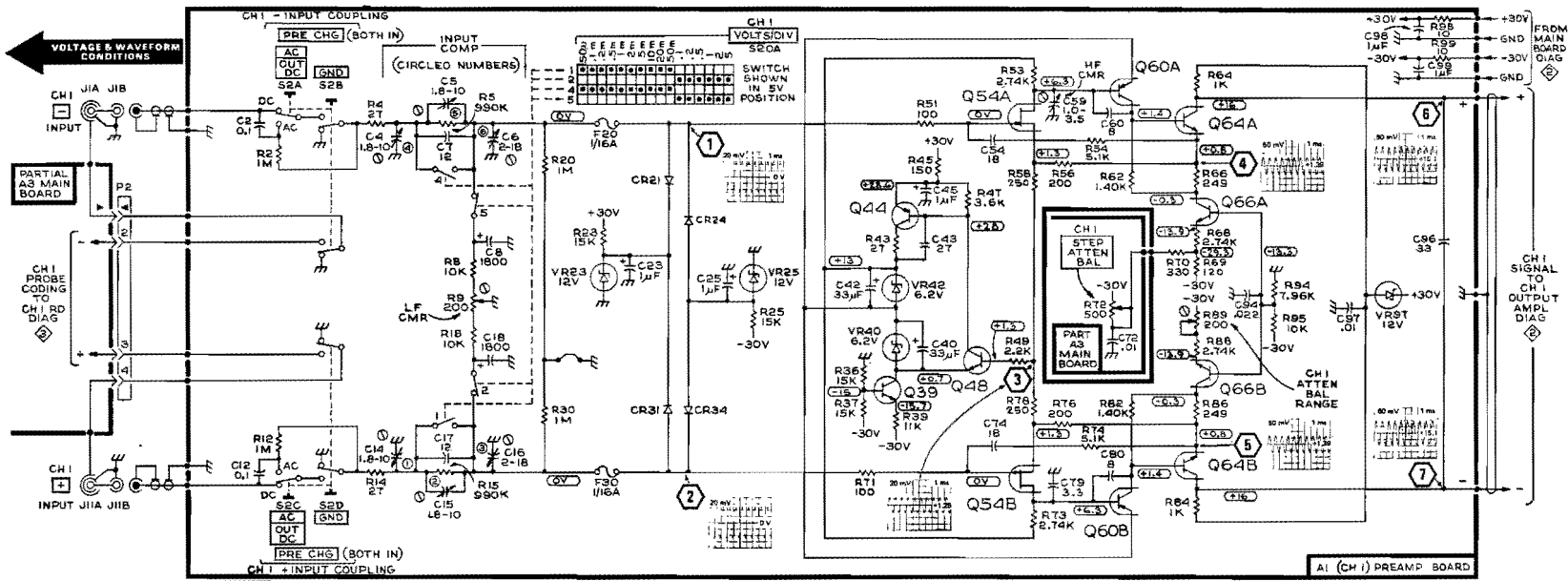

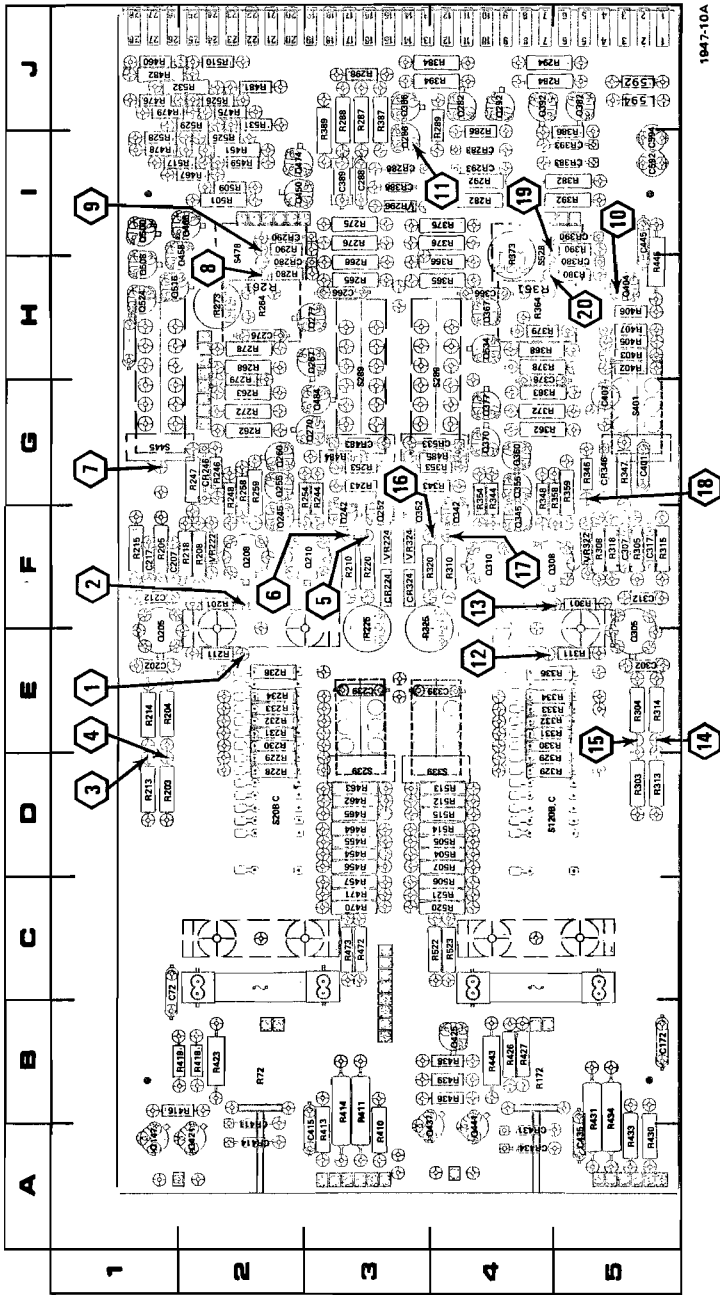

Fig. 4-6. A3—Main circuit board test point locations.

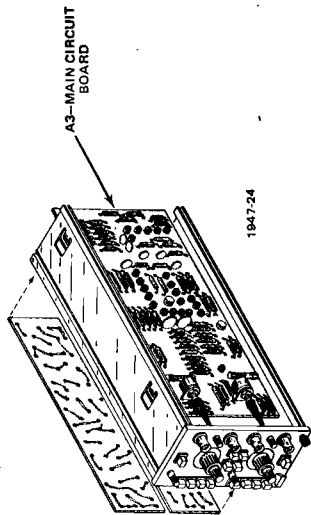

Fig. 4-7. A3—Main circuit board location.

VOLTAGE AND WAVEFORM CONDITIONS

The voltages and waveforms shown on this diagram were obtained from a calibrated 5A26 with the following recommended test equipment and set-up.

RECOMMENDED TEST EQUIPMENT

Item	Description	Recommended Type
Oscilloscope system	Deflection factor, 2 mV/div to 5 V/div. Input impedance, 1 M Ω . Frequency response, dc to 1 MHz.	Tektronix 5440 Oscilloscope with 5A15N Amplifier, P6062B 10X probe, and 5B10N Time Base Amplifier.
Voltmeter (non-loading digital multimeter)	Input impedance, 10 M Ω . Dc voltage range, ± 2 V to ± 30 V (full scale).	Tektronix DM502 Digital Multimeter with TM 500-series Power Module.
Sine wave generator	Frequency range, 1 kHz. Output amplitude, 10 V p-p (0 V dc offset).	Tektronix FG 503 Function Generator with TM 500-series Power Module.
Plug-in extension cable	Capable of extending 5A26 from oscilloscope plug-in compartment.	Tektronix part no. 067-0645-03.

VOLTAGES

Dc voltages are measured with no signal applied. The voltmeter common is connected to chassis ground. The 5A26 is connected to the oscilloscope left vertical plug-in compartment through the plug-in extension cable and the controls are set as follows:

Control Settings

NOTE

The following control settings apply for either input of CH 1 or CH 2.

VOLTS/DIV	5	MODE¹	CH 1 (button in)
+ Input Coupling		BW LIMIT	OUT:1 MHz (button out)
AC	OUT:DC (button out)	DISPLAY	ON (button in)
GND	GND (button in)	POS	Position trace to center screen
- Input Coupling			
AC	OUT:DC (button in)		
GND	GND (button in)		

Voltages are accurate to within 20%.

¹Voltages with \uparrow on this diagram apply only with CH 1 MODE button pressed in.

WAVEFORMS

The 5A26 is connected to the oscilloscope left vertical plug-in compartment through the plug-in extension cable. The amplifier plug-in is inserted to the right vertical oscilloscope plug-in compartment and the time-base plug-in is inserted in the extreme right oscilloscope plug-in compartment. A 1 kilohertz, 10 volt peak-to-peak sine wave is applied to the + or - input (single-ended). Waveforms are taken through the 10X probe and are accurate to within 20%.

Control Settings

NOTE

The following control settings apply for either input of CH 1 or CH 2.

VOLTS/DIV	2	MODE	CH 1 (button in)
+ Input Coupling		TRIGGER	OUT:CH 1 (button out)
AC	OUT:DC (button in)	BW LIMIT	OUT:1 MHz (button out)
GND	Off (button out)	DISPLAY	ON (button in)
- Input Coupling		POS	Position trace to center screen
AC	OUT:DC (button in)		
GND	Off (button out)		

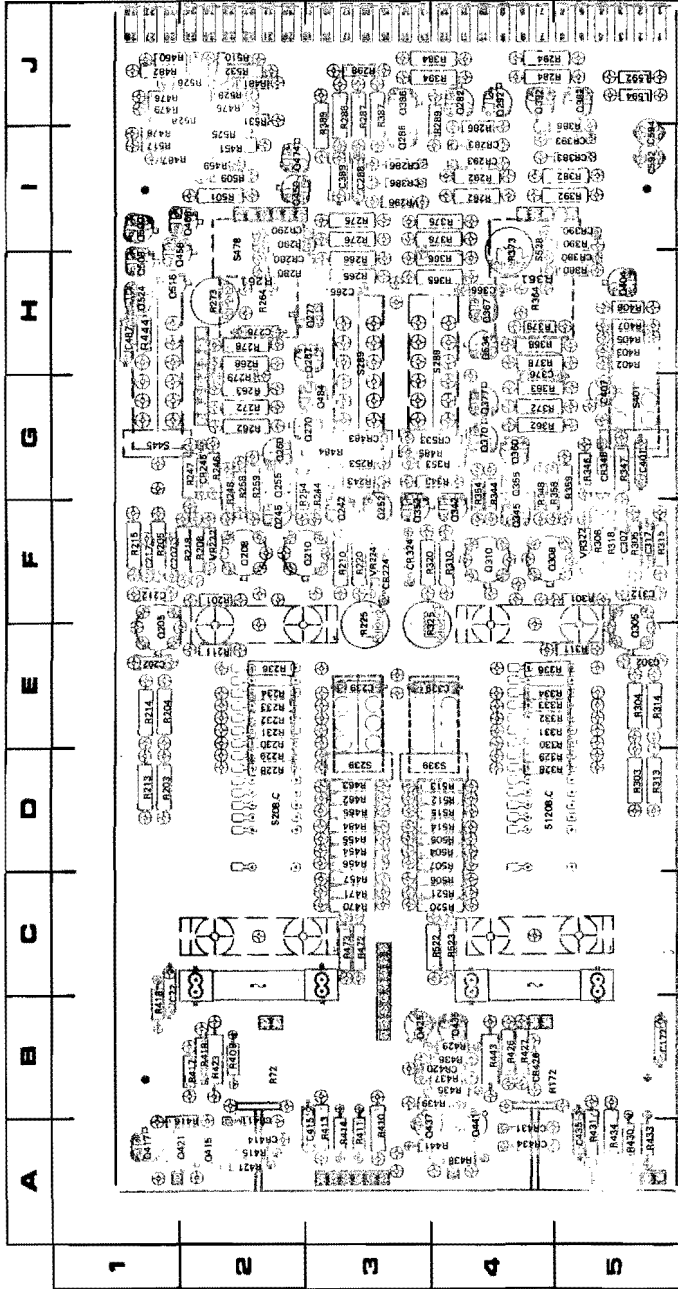

194721

Fig. 4-8. A3—Main circuit board component locations (SN B020000 & up).

VOLTAGE CONDITIONS

The dc voltages shown on this diagram were obtained from a calibrated 5A26 with the following test equipment and set-up.

RECOMMENDED TEST EQUIPMENT

Item	Description	Recommended Type
Voltmeter (Non-loading digital multimeter)	Input impedance: 10 M Ω . Dc voltage range: ± 2 V to ± 200 V (full scale)	Tektronix DM502 Digital Multimeter with TM 500-series Power Module.
Plug-in Extension Cable	Capable of extending 5A26 from oscilloscope plug-in compartment.	Tektronix part no. 067-0645-03.
10X Probe with readout coding connector	Readout coding resistance: 11 k Ω .	Tektronix P6062B Probe.

Dc voltages are measured with no signal applied. The voltmeter common is connected to chassis ground. The 5A26 is connected to the oscilloscope left vertical plug-in compartment through the plug-in extension cable. The 10X probe is connected to the CH 2 + input and the controls are set as follows:

Control Settings

CH 2 + GND	Off (button out)
CH 1 and CH 2 MODE	In (dual trace)

Voltages are accurate to within 20%.

VOLTAGE & WAVEFORM CONDITIONS

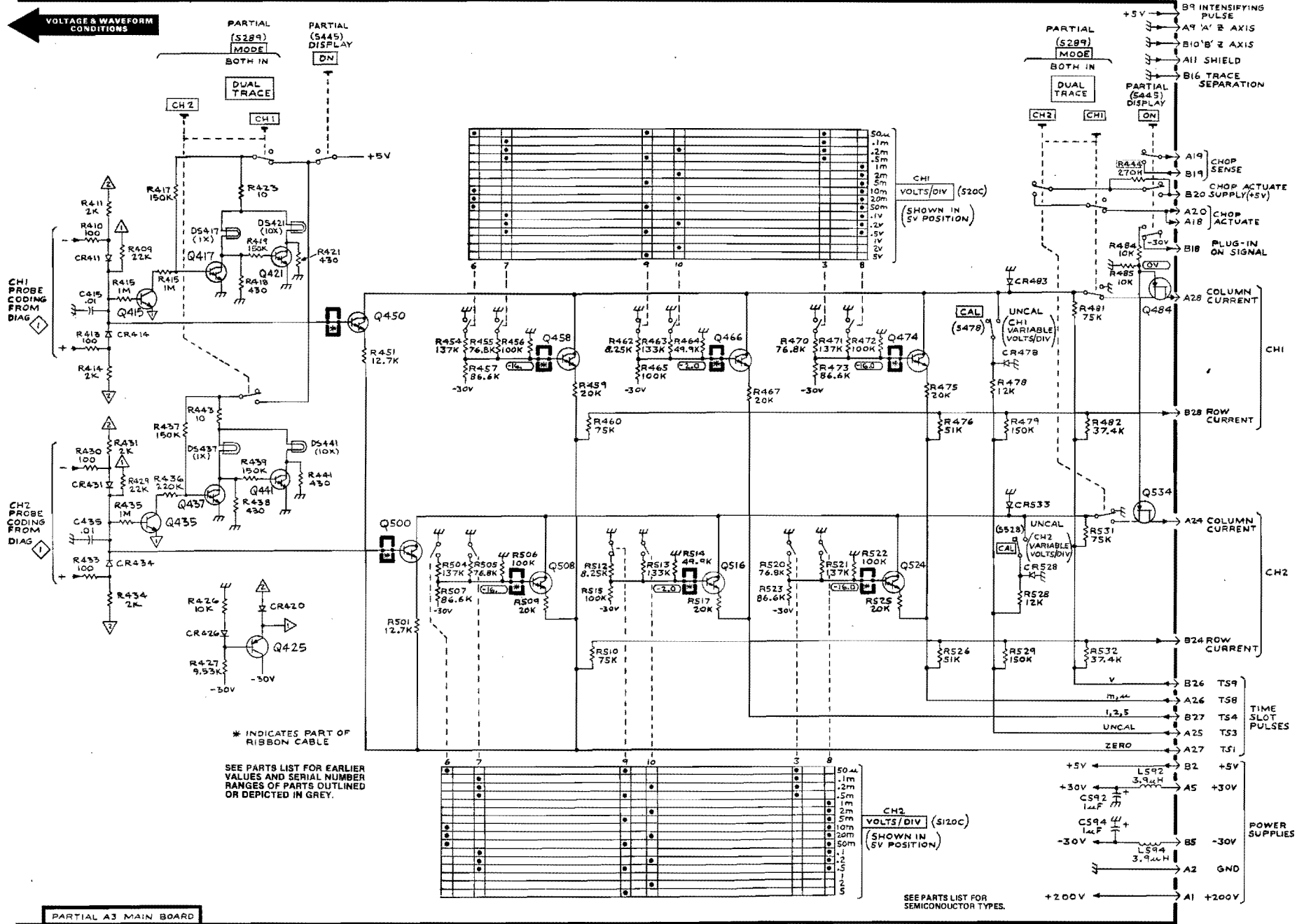

* INDICATES PART OF RIBBON CABLE

SEE PARTS LIST FOR EARLIER VALUES AND SERIAL NUMBER RANGES OF PARTS OUTLINED OR DEPICTED IN GREY.

SEE PARTS LIST FOR SEMICONDUCTOR TYPES.

(5N021000-UP)
READOUT 3

VOLTAGE & WAVEFORM CONDITIONS

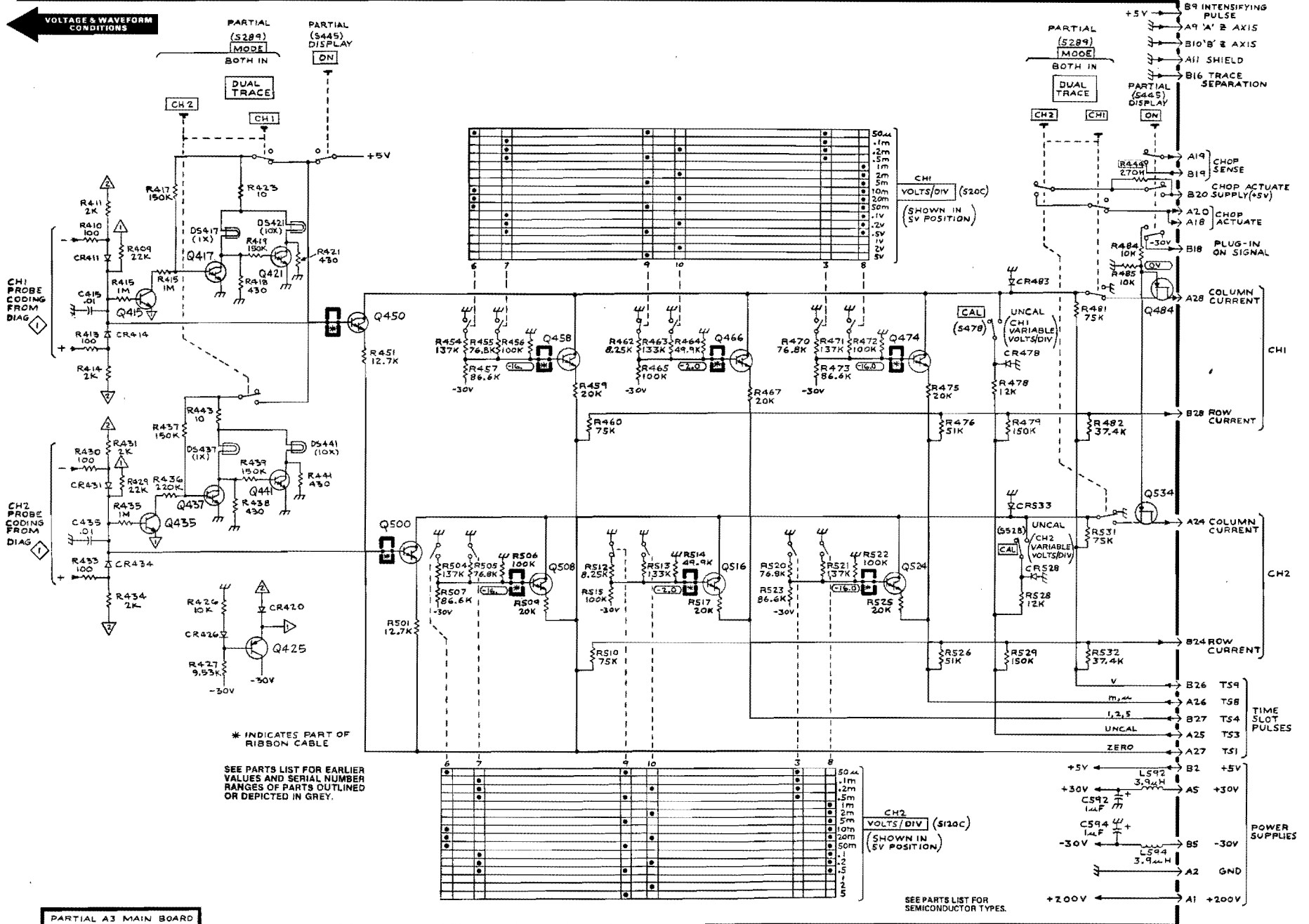

REPLACEABLE MECHANICAL PARTS

PARTS ORDERING INFORMATION

Replacement parts are available from or through your local Tektronix, Inc. Field Office or representative.

Changes to Tektronix instruments are sometimes made to accommodate improved components as they become available, and to give you the benefit of the latest circuit improvements developed in our engineering department. It is therefore important, when ordering parts, to include the following information in your order: Part number, instrument type or number, serial number, and modification number if applicable.

If a part you have ordered has been replaced with a new or improved part, your local Tektronix, Inc. Field Office or representative will contact you concerning any change in part number.

Change information, if any, is located at the rear of this manual.

SPECIAL NOTES AND SYMBOLS

X000 Part first added at this serial number
00X Part removed after this serial number

FIGURE AND INDEX NUMBERS

Items in this section are referenced by figure and index numbers to the illustrations.

INDENTATION SYSTEM

This mechanical parts list is indented to indicate item relationships. Following is an example of the indentation system used in the description column.

```

1 2 3 4 5           Name & Description
Assembly and/or Component
Attaching parts for Assembly and/or Component
    ---*---
Detail Part of Assembly and/or Component
Attaching parts for Detail Part
    ---*---
Parts of Detail Part
Attaching parts for Parts of Detail Part
    ---*---
  
```

Attaching Parts always appear in the same indentation as the item it mounts, while the detail parts are indented to the right. Indented items are part of, and included with, the next higher indentation. The separation symbol ---*--- indicates the end of attaching parts.

Attaching parts must be purchased separately, unless otherwise specified.

ITEM NAME

In the Parts List, an Item Name is separated from the description by a colon (:). Because of space limitations, an Item Name may sometimes appear as incomplete. For further Item Name identification, the U.S. Federal Cataloging Handbook H6-1 can be utilized where possible.

ABBREVIATIONS

"	INCH	ELCTRN	ELECTRON	IN	INCH	SE	SINGLE END
#	NUMBER SIZE	ELEC	ELECTRICAL	INCAND	INCANDESCENT	SECT	SECTION
ACTR	ACTUATOR	ELCTLT	ELECTROLYTIC	INSUL	INSULATOR	SEMICOND	SEMICONDUCTOR
ADPTR	ADAPTER	ELEM	ELEMENT	INTL	INTERNAL	SHLD	SHIELD
ALIGN	ALIGNMENT	EPL	ELECTRICAL PARTS LIST	LPHLDR	LAMPHOLDER	SHLDR	SHOULDERED
AL	ALUMINUM	EQPT	EQUIPMENT	MACH	MACHINE	SKT	SOCKET
ASSEM	ASSEMBLED	EXT	EXTERNAL	MECH	MECHANICAL	SL	SLIDE
ASSY	ASSEMBLY	FIL	FILLISTER HEAD	MTG	MOUNTING	SLFLKG	SELF-LOCKING
ATTEN	ATTENUATOR	FLEX	FLEXIBLE	NIP	NIPPLE	SLVG	SLEEVEING
AWG	AMERICAN WIRE GAGE	FLH	FLAT HEAD	NON WIRE	NOT WIRE WOUND	SPR	SPRING
BD	BOARD	FLTR	FILTER	OBD	ORDER BY DESCRIPTION	SQ	SQUARE
BRKT	BRACKET	FR	FRAME or FRONT	OD	OUTSIDE DIAMETER	SST	STAINLESS STEEL
BRS	BRASS	FSTNR	FASTENER	OVB	OVAL HEAD	STL	STEEL
BRZ	BRONZE	FT	FOOT	PH BRZ	PHOSPHOR BRONZE	SW	SWITCH
BSHG	BUSHING	FXD	FIXED	PL	PLAIN or PLATE	T	TUBE
CAB	CABINET	GSKT	GASKET	PLSTC	PLASTIC	TERM	TERMINAL
CAP	CAPACITOR	HDL	HANDLE	PN	PART NUMBER	THD	THREAD
CER	CERAMIC	HEX	HEXAGON	PNH	PAN HEAD	THK	THICK
CHAS	CHASSIS	HEX HD	HEXAGONAL HEAD	PWR	POWER	TNSN	TENSION
CKT	CIRCUIT	HEX SOC	HEXAGONAL SOCKET	RCPT	RECEPTACLE	TPG	TAPPING
COMP	COMPOSITION	HLCPS	HELICAL COMPRESSION	RES	RESISTOR	TRH	TRUSS HEAD
CONN	CONNECTOR	HLEXT	HELICAL EXTENSION	RGD	RIGID	V	VOLTAGE
COV	COVER	HV	HIGH VOLTAGE	RLF	RELIEF	VAR	VARIABLE
CPLG	COUPLING	IC	INTEGRATED CIRCUIT	RTNR	RETAINER	W/	WITH
CRT	CATHODE RAY TUBE	ID	INSIDE DIAMETER	SCH	SOCKET HEAD	WSHR	WASHER
DEG	DEGREE	IDNT	IDENTIFICATION	SCOPE	OSCILLOSCOPE	XFMR	TRANSFORMER
DWR	DRAWER	IMPLR	IMPELLER	SCR	SCREW	XSTR	TRANSISTOR

CROSS INDEX—MFR. CODE NUMBER TO MANUFACTURER

Mfr. Code	Manufacturer	Address	City, State, Zip
000BK	STAUFFER SUPPLY	105 SE TAYLOR	PORTLAND, OR 97214
000CY	NORTHWEST FASTENER SALES, INC.	7923 SW CIRRUS DRIVE	BEAVERTON, OREGON 97005
08261	SPECTRA-STRIP CORP.	7100 LAMPSON AVE.	GARDEN GROVE, CA 92642
15912	ANSLEY ELECTRONICS CORP., A SUB OF THOMAS AND BETTS CORP.	3208 HUMBOLDT ST.	LOS ANGELES, CA 90065
22526	BERG ELECTRONICS, INC.	YOUK EXPRESSWAY	NEW CUMBERLAND, PA 17070
28520	HEYMAN MFG. CO.	147 N. MICHIGAN AVE.	KENILWORTH, NJ 07033
45722	USM CORP., PARKER-KALON FASTENER DIV.		CAMPBELLSVILLE, KY 42718
55210	GETTIG ENG. AND MFG. COMPANY	PO BOX 85, OFF ROUTE 45	SPRING MILLS, PA 16875
71400	BUSSMAN MFG., DIVISION OF MCGRAW- EDISON CO.	2536 W. UNIVERSITY ST.	ST. LOUIS, MO 63107
71785	TRW, CINCH CONNECTORS	1501 MORSE AVENUE	ELK GROVE VILLAGE, IL 60007
73743	FISCHER SPECIAL MFG. CO.	446 MORGAN ST.	CINCINNATI, OH 45206
74445	HOLO-KROME CO.	31 BROOK ST. WEST	HARTFORD, CT 06110
78189	ILLINOIS TOOL WORKS, INC. SHAKEPROOF DIVISION	ST. CHARLES ROAD	ELGIN, IL 60120
78471	TILLEY MFG. CO.	900 INDUSTRIAL RD.	SAN CARLOS, CA 94070
80009	TEKTRONIX, INC.	P O BOX 500	BEAVERTON, OR 97077
83385	CENTRAL SCREW CO.	2530 CRESCENT DR.	BROADVIEW, IL 60153
93907	CAMCAR SCREW AND MFG. CO.	600 18TH AVE.	ROCKFORD, IL 61101
97464	INDUSTRIAL RETAINING RING CO.	57 CORDIER ST.	IRVINGTON, NJ 07111

Fig. & Index No.	Tektronix Part No.	Serial/Model No. Eff Dscont	Qty	1	2	3	4	5	Name & Description	Mfr Code	Mfr Part Number
1-1	337-1399-00		2						SHLD,ELECTRICAL:SIDE	80009	337-1399-00
-2	366-1317-00		2						KNOB:RED	80009	366-1317-00
	213-0153-00		1						. SETSCREW:5-40 X 0.125,STL BK OXD,HEX	000CY	OBD
-3	366-1618-00		2						KNOB:GRAY	80009	366-1618-00
	213-0153-00		2						. SETSCREW:5-40 X 0.125,STL BK OXD,HEX	000CY	OBD
-4	384-1114-00		2						EXTENSION SHAFT:7.6 LG X 0.125 OD W/KNOB	80009	384-1114-00
-5	358-0378-00		2						BUSHING,SLEEVE:PRESS MOUNT	80009	358-0378-00
-6	366-1564-00		2						KNOB:GRAY PLASTIC,PRESS MT	80009	366-1564-00
-7	366-1257-14		1						PUSH BUTTON:GRAY--ON	80009	366-1257-14
-8	366-1257-11		4						PUSH BUTTON:GRAY--AC PRE	80009	366-1257-11
-9	366-1257-12		4						PUSH BUTTON:GRAY--CHG GND	80009	366-1257-12
-10	366-1257-17		1						PUSH BUTTON:GRAY--CH1 DUAL	80009	366-1257-17
-11	366-1257-18		1						PUSH BUTTON:GRAY--TRACE CH 2	80009	366-1257-18
-12	366-1257-77		2						PUSH BUTTON:GRAY	80009	366-1257-77
-13	366-1557-20		1						PUSH BUTTON:GRAY	80009	366-1557-20
-14	366-1286-02	B010100 B019999	1						KNOB,LATCH:	80009	366-1286-02
	366-1690-00	B020000	1						KNOB,LATCH:	80009	366-1690-00
									(ATTACHING PARTS)		
-15	214-1840-00	B010100 B019999X	1						PIN,KNOB SECRG:0.094 OD X 0.120 INCH LONG	80009	214-1840-00
									- - - * - - -		
-16	-----		4						CONN,RCPT,ELEC:(SEE J1,J11,J101 J111 EPL)		
-17	426-0681-00		14						FR,PUSH BUTTON:GRAY PLASTIC	80009	426-0681-00
-18	358-0029-00		2						BSHG,MACH.THD:HEX,0.375-32 X 0.438"LONG	80009	358-0029-00
									(ATTACHING PARTS)		
-19	210-0590-00		2						NUT,PLAIN,HEX.:0.375 X 0.438 INCH,STL	73743	2X28269-402
	210-0012-00		4						WASHER,LOCK:INTL,0.375 ID X 0.50" OD STL	78189	1220-02-00-0541C
-20	210-0978-00		2						WASHER,FLAT:0.375 ID X 0.50 INCH OD,STL	78471	OBD
									- - - * - - -		
-21	344-0195-01		1						CLIP,ELECTRICAL:CAM SHAFT	80009	344-0195-01
-22	220-0633-00		1						NUT,PLAIN,KNURL:0.25-28 X 0.25 INCH L,BRS	80009	220-0633-00
-23	333-1874-00		1						PANEL,FRONT:	80009	333-1874-00
									(ATTACHING PARTS)		
-24	355-0170-00		1						STUD,SHOULDERED:6-32 X 0.40 INCH LONG	80009	355-0170-00
									- - - * - - -		
	358-0378-00	B010100 B021271	2						BUSHING,SLEEVE:PRESS MOUNT	80009	358-0378-00
	358-0599-00	B021272	2						BUSHING,SLEEVE:0.125 ID X 0.234 THK,PLSTC	28520	B-187-125
-25	214-1513-01	B010100 B019999	1						LCH,PLUG-IN RET:	80009	214-1513-01
	105-0718-00	B020000 B031421	1						BAR,LATCH RLSE:	80009	105-0718-00
	105-0718-01	B031422	1						BAR,LATCH RLSE:	80009	105-0718-01
									(ATTACHING PARTS)		
-26	213-0254-00		1						SCREW,TPG,TF:2-32 X 0.250,100 DEG,FLH	45722	OBD
									- - - * - - -		
	105-0719-00	XB020000	1						LATCH,RETAINING:PLUG-IN	80009	105-0719-00
-27	378-0729-00		4						LENS,LIGHT:CLEAR	80009	378-0729-00
-28	-----		4						LAMP,GLOW:(SEE DS417,421,437,441 EPL)		
-29	200-1860-00		4						COVER,LAMP:	80009	200-1860-00
-30	386-2896-00		1						SUBPANEL,FRONT:	80009	386-2896-00
									(ATTACHING PARTS)		
-31	213-0229-00		3						SCR,TPG,THD FOR:6-20 X0.375"100 DEG,FLH STL	93907	OBD
									- - - * - - -		
-32	337-2005-00		1						SHIELD,ELEC:	80009	337-2005-00
-33	384-1059-00		4						EXTENSION SHAFT:6.58 INCH LONG	80009	384-1059-00
-34	384-1061-00		2						EXTENSION SHAFT:3.981 INCH LONG	80009	384-1061-00
-35	384-1121-00		2						EXTENSION SHAFT:1.41 INCH LONG	80009	384-1121-00
-36	337-2199-00		1						SHIELD,ELEC:CIRCUIT CARD	80009	337-2199-00
-37	334-2360-00	B010100 B019999X	1						MARKER,IDENT:WARNING	80009	334-2360-00
-38	175-1405-00		1						CA ASSY,SP,ELEC:FLAT,2.0 LONG	15912	FST 22A-10
									(DIVIDED INTO 2 SEPARATE 5 CONDUCTOR WIDTHS)		
	672-0527-00	B010100 B019999	1						CKT BOARD ASSY:MAIN AND PRE AMP	80009	672-0527-00
	672-0527-01	B020000	1						CKT BOARD ASSY:MAIN & PREAMPL	80009	672-0527-01
									(ATTACHING PARTS)		
-39	213-0336-00		2						SCR,TPG,THD FOR:6-32 X 1.25 INCH,PNH STL	000BK	OBD
-40	213-0146-00		2						SCR,TPG,THD FOR:6-20 X 0.313 INCH,PNH STL	83385	OBD
-41	361-0516-00		2						SPACER,SLEEVE:0.189 OD X 0.986"LONG BRS	80009	361-0516-00
									- - - * - - -		

Reaplaceable Mechanical Parts—5A26

Fig. & Index No.	Tektronix Part No.	Serial/Model No. Eff	Dscont	Qty	1 2 3 4 5	Name & Description	Mfr Code	Mfr Part Number
1-	-----	-----		-	.	CKT BOARD ASSY INCLUDES:		
-42	-----	-----		2	.	CKT BOARD ASSY:PRE AMPL(SEE A1 AND A2 EPL) (ATTACHING PARTS FOR EACH)		
-43	211-0116-00	B010100	B010209	4	.	SCR,ASSEM WSHR:4-40 X 0.312 INCH,PNH BRS	83385	OBD
	211-0207-00	B010210	B021261	4	.	SCR,ASSEM WSHR:4-40 X 0.312 DOUBLE SEMS	83385	OBD
	211-0116-00	B021262		4	.	SCR,ASSEM WSHR:4-40 X 0.312 INCH,PNH BRS	83385	OBD
	-----	-----		-	.	EACH CKT BOARD INCLUDES:		
-44	-----	-----		1	.	SWITCH,PUSH:(SEE S2 AND S102 EPL)		
-45	361-0382-00			4	.	SPACER,PB SW:BROWN,0.275 INCH LONG	80009	361-0382-00
-46	337-2200-00			2	.	SHIELD,ELEC:	80009	337-2200-00
-47	344-0154-00			4	.	CLIP,ELECTRICAL:FOR 0.25 INCH DIA FUSE	80009	344-0154-00
-48	200-0687-01			1	.	COV,TRANSISTOR:0.438 DIA X 0.47 INCH H	80009	200-0687-01
-49	136-0235-00			4	.	SOCKET,PLUG-IN:6 CONTACT,ROUND	71785	133-96-12-062
-50	131-0566-00			1	.	LINK,TERM.CONNE:0.086 DIA X 2.375 INCH L	55210	L-2007-1
-51	376-0051-01			1	.	CPLG,SHAFT,FLEX:0.127 ID X 0.375 OD	80009	376-0051-01
-52	-----	-----		1	.	RES.,VARIABLE:(SEE R274,R374 EPL) (ATTACHING PARTS)		
-53	210-0583-00			1	.	NUT,PLAIN,HEX.:0.25-32 X 0.312 INCH,BRS	73743	2X20317-402
-54	210-0046-00			1	.	WASHER,LOCK:INTL,0.26 ID X 0.40" OD,STL	78189	1214-05-00-0541C
-55	386-2273-00			1	.	PL,VAR RES MTG:HORIZONTAL CKT BD	80009	386-2273-00
-56	131-0604-00			4	.	CONTACT,ELEC:CKT BD SW,SPR,CU BE	80009	131-0604-00
	-----	-----		2	.	ACTR ASSY,CAM S:(SEE S20,S120 EPL) (ATTACHING PARTS FOR EACH)		
-57	211-0116-00	B010100	B010209	4	.	SCR,ASSEM WSHR:4-40 X 0.312 INCH,PNH BRS	83385	OBD
	211-0207-00	B010210	B021261	4	.	SCR,ASSEM WSHR:4-40 X 0.312 DOUBLE SEMS	83385	OBD
	211-0116-00	B021262		4	.	SCR,ASSEM WSHR:4-40 X 0.312 INCH,PNH BRS	83385	OBD
	334-3448-00	XB041592		1	.	MARKER,IDENT:MARKED NOTICE	80009	334-3448-00
	-----	-----		-	.	EACH ACTUATOR INCLUDES:		
-58	210-0406-00			4	.	NUT,PLAIN,HEX.:4-40 X 0.188 INCH,BRS	73743	2X12161-402
-59	214-1139-02			2	.	SPRING,FLAT:GREEN COLORED	80009	214-1139-02
-60	214-1127-00			2	.	ROLLER,DETENT:0.125 DIA X 0.125 INCH L	80009	214-1127-00
-61	401-0081-02			1	.	BEARING,CAM SW:FRONT (ATTACHING PARTS)	80009	401-0081-02
-62	354-0391-00			1	.	RING,RETAINING:0.395"FREE ID X 0.025" STL	97464	3100-43-CD
-63	105-0691-00			1	.	ACTUATOR,CAM SW:VOLTS/DIV	80009	105-0691-00
-64	401-0115-00			1	.	BEARING,CAM SW:CENTER	80009	401-0115-00
-65	384-0162-00			2	.	EXTENSION SHAFT:8.564 L X 0.125 OD AL	80009	384-0162-00
-66	376-0051-01			2	.	CPLG,SHAFT,FLEX:0.127 ID X 0.375 OD	80009	376-0051-01
	213-0048-00			4	.	SETSCREW:4-40 X 0.125 INCH,HEX SOC STL	74445	OBD
-67	-----	-----		-	.	RES,VARIABLE:(SEE R264,R364 EPL)		
-68	-----	-----		-	.	CKT BOARD ASSY:MAIN(SEE A3 EPL)		
-69	131-0604-00			30	.	CONTACT,ELEC:CKT BD SW,SPR,CU BE	80009	131-0604-00
-70	-----	-----		1	.	SWITCH,PUSH:(SEE S445 EPL)		
-71	361-0383-00			2	.	SPACER,PB SW:CHARCOAL,0.33 INCH LONG	80009	361-0383-00
-72	-----	-----		1	.	SWITCH,PUSH:(SEE S401 EPL)		
-73	361-0383-00			2	.	SPACER,PB SW:CHARCOAL,0.33 INCH LONG	80009	361-0383-00
-74	-----	-----		1	.	SWITCH,PUSH:(SEE S289 EPL)		
-75	361-0383-00			4	.	SPACER,PB SW:CHARCOAL,0.33 INCH LONG	80009	361-0383-00
-76	-----	-----		2	.	SWITCH,PUSH:(SEE S239,S339 EPL)		
	361-0685-00	XB010135		4	.	SPACER,SWITCH:0.365 INCH LONG	80009	361-0685-00
-77	-----	-----		2	.	RES.,VARIABLE:(SEE R72,R172 EPL) (ATTACHING PARTS FOR EACH)		
-78	210-0583-00			1	.	NUT,PLAIN,HEX.:0.25-32 X 0.312 INCH,BRS	73743	2X20317-402
-79	210-0046-00			1	.	WASHER,LOCK:INTL,0.26 ID X 0.40" OD,STL	78189	1214-05-00-0541C
-80	386-2273-00			2	.	PL,VAR RES MTG:HORIZONTAL CKT BD	80009	386-2273-00
-81	344-0154-00			4	.	CLIP,ELECTRICAL:FOR 0.25 INCH DIA FUSE	80009	344-0154-00
-82	159-0024-00			2	.	FUSE,CARTRIDGE:3AG,0.06A,250V,FAST BLOW	71400	AGC 1/16
-83	136-0235-00			6	.	SOCKET,PLUG-IN:6 CONTACT,ROUND	71785	133-96-12-062
-84	131-0608-00			8	.	TERMINAL,PIN:0.365 L X 0.25 PH,BRZ,GOLD PL	22526	47357

Fig. & Index No.	Tektronix Part No.	Serial/Model No.		Qty	1 2 3 4 5	Name & Description	Mfr	
		Eff	Dscont				Code	Mfr Part Number
1-85	426-0724-01			1		FR SECT, PLUG-IN: BOTTOM	80009	426-0724-01
-86	426-0725-01	B010100	B051677	1		FR SECT, PLUG-IN: TOP	80009	426-0725-01
	426-0725-00	B051678		1		FR SECT, PLUG-IN: TOP	80009	426-0725-00
-87	175-0826-00			FT		WIRE, ELECTRICAL: 3 WIRE RIBBON	80009	175-0826-00
-88	175-0827-00			FT		WIRE, ELECTRICAL: 4 WIRE RIBBON	08261	SS-0426-710610C
-89	175-0831-00			FT		WIRE, ELECTRICAL: 8 WIRE RIBBON	08261	OBD
-90	352-0162-01			2		CONN BODY, PL, EL: 4 WIRE BROWN	80009	352-0162-01

ACCESSORIES

070-1947-00				1		MANUAL, TECH: INSTRUCTION (NOT SHOWN)	80009	070-1947-00
-------------	--	--	--	---	--	---------------------------------------	-------	-------------

Fig. & Index No.	Tektronix Part No.	Serial/Model No. Eff	Dscont	Qty	1	2	3	4	5	Name & Description	Mfr Code	Mfr Part Number
1-85	426-0724-01			1						FR SECT, PLUG-IN: BOTTOM	80009	426-0724-01
-86	426-0725-01	B010100	B051677	1						FR SECT, PLUG-IN: TOP	80009	426-0725-01
	426-0725-00	B051678		1						FR SECT, PLUG-IN: TOP	80009	426-0725-00
-87	175-0826-00			FT						WIRE, ELECTRICAL: 3 WIRE RIBBON	80009	175-0826-00
-88	175-0827-00			FT						WIRE, ELECTRICAL: 4 WIRE RIBBON	08261	SS-0426-710610C
-89	175-0831-00			FT						WIRE, ELECTRICAL: 8 WIRE RIBBON	08261	0BD
-90	352-0162-01			2						CONN BODY, PL, EL: 4 WIRE BROWN	80009	352-0162-01

ACCESSORIES

070-1947-00				1						MANUAL, TECH: INSTRUCTION(NOT SHOWN)	80009	070-1947-00
-------------	--	--	--	---	--	--	--	--	--	--------------------------------------	-------	-------------

FIG. 1 EXPLODED

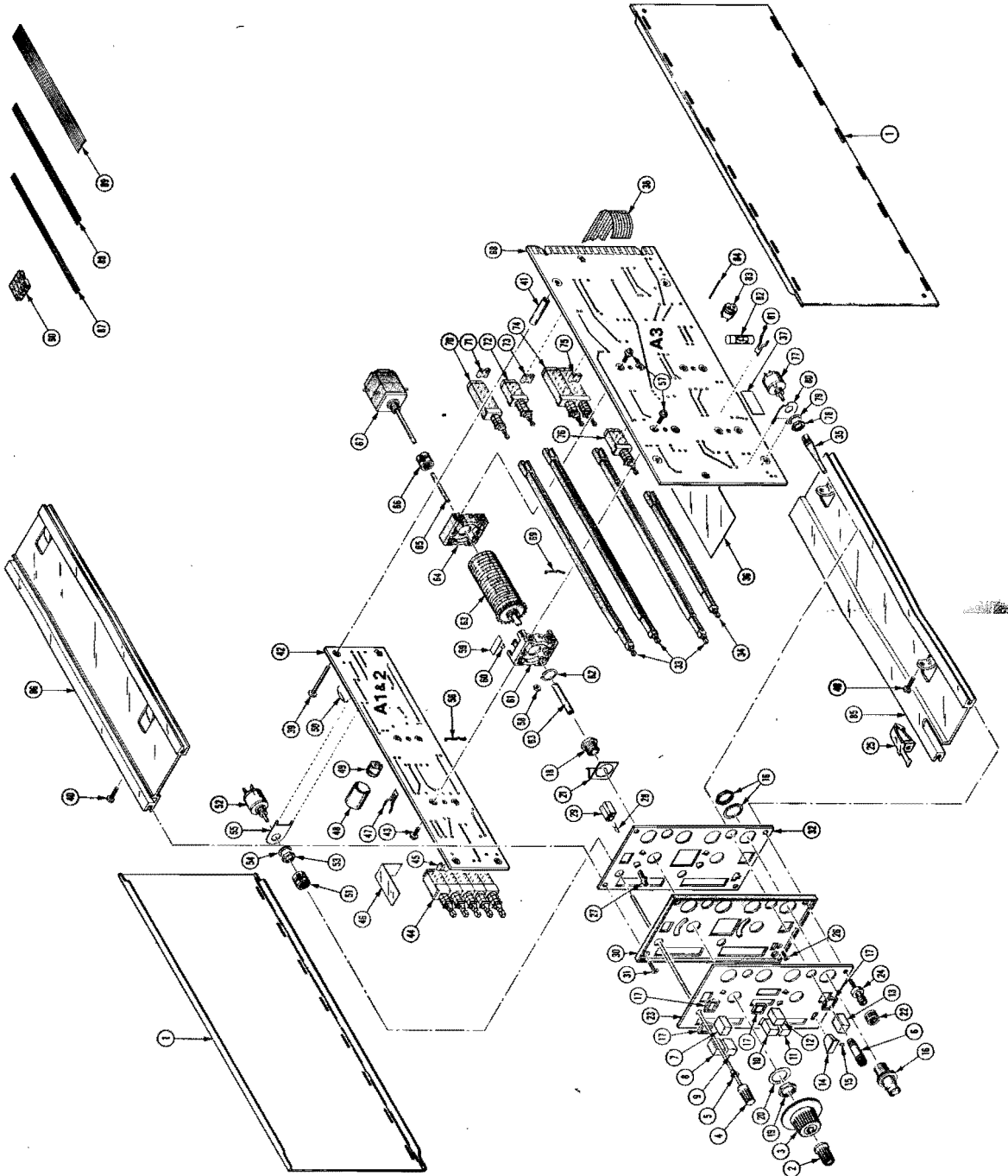

MANUAL CHANGE INFORMATION

At Tektronix, we continually strive to keep up with latest electronic developments by adding circuit and component improvements to our instruments as soon as they are developed and tested.

Sometimes, due to printing and shipping requirements, we can't get these changes immediately into printed manuals. Hence, your manual may contain new change information on following pages.

A single change may affect several sections. Since the change information sheets are carried in the manual until all changes are permanently entered, some duplication may occur. If no such change pages appear following this page, your manual is correct as printed.

SERVICE NOTE

Because of the universal parts procurement problem, some electrical parts in your instrument may be different from those described in the Replaceable Electrical Parts List. The parts used will in no way alter or compromise the performance or reliability of this instrument. They are installed when necessary to ensure prompt delivery to the customer. Order replacement parts from the Replaceable Electrical Parts List.

CALIBRATION TEST EQUIPMENT REPLACEMENT

Calibration Test Equipment Chart

This chart compares TM 500 product performance to that of older Tektronix equipment. Only those characteristics where significant specification differences occur, are listed. In some cases the new instrument may not be a total functional replacement. Additional support instrumentation may be needed or a change in calibration procedure may be necessary.

Comparison of Main Characteristics

DM 501 replaces 7D13		
PG 501 replaces 107 108	PG 501 - Risetime less than 3.5 ns into 50 Ω . PG 501 - 5 V output pulse; 3.5 ns Risetime	107 - Risetime less than 3.0 ns into 50 Ω . 108 - 10 V output pulse 1 ns Risetime
PG 502 replaces 107 108 111	PG 502 - 5 V output PG 502 - Risetime less than 1 ns; 10 ns Pretrigger pulse delay	108 - 10 V output 111 - Risetime 0.5 ns; 30 to 250 ns Pretrigger pulse delay
PG 508 replaces 114 115 2101	Performance of replacement equipment is the same or better than equipment being replaced.	
PG 506 replaces 106 067-0502-01	PG 506 - Positive-going trigger output signal at least 1 V; High Amplitude output, 60 V. PG 506 - Does not have chopped feature.	106 - Positive and Negative-going trigger output signal, 50 ns and 1 V; High Amplitude output, 100 V. 0502-01 - Comparator output can be alternately chopped to a reference voltage.
SG 503 replaces 190, 190A, 190B 191 067-0532-01	SG 503 - Amplitude range 5 mV to 5.5 V p-p. SG 503 - Frequency range 250 kHz to 250 MHz.	190B - Amplitude range 40 mV to 10 V p-p. 0532-01 - Frequency range 65 MHz to 500 MHz.
SG 504 replaces 067-0532-01 067-0650-00	SG 504 - Frequency range 245 MHz to 1050 MHz.	0532-01 - Frequency range 65 MHz to 500 MHz.
TG 501 replaces 180, 180A 181 184 2901	TG 501 - Trigger output-slaved to marker output from 5 sec through 100 ns. One time-mark can be generated at a time. TG 501 - Trigger output-slaved to market output from 5 sec through 100 ns. One time-mark can be generated at a time. TG 501 - Trigger output-slaved to marker output from 5 sec through 100 ns. One time-mark can be generated at a time.	180A - Trigger pulses 1, 10, 100 Hz; 1, 10, and 100 kHz. Multiple time-marks can be generated simultaneously. 181 - Multiple time-marks 184 - Separate trigger pulses of 1 and 0.1 sec; 10, 1, and 0.1 ms; 10 and 1 μ s. 2901 - Separate trigger pulses, from 5 sec to 0.1 μ s. Multiple time-marks can be generated simultaneously.

NOTE: All TM 500 generator outputs are short-proof. All TM 500 plug-in instruments require TM 500-Series Power Module.

CHANGE	DESCRIPTION	
ELECTRICAL PARTS LIST AND SCHEMATIC CHANGES		
CHANGE TO:		
A3	670-3143-02	CKT BOARD ASSY:MAIN
C389	283-0115-00	CAP.,FXD,CER DI:47PF,5%,200V
Q282	151-1025-00	TRANSISTOR:SILICON,FET,N-CHANNEL,2N4416
Q292	151-1025-00	TRANSISTOR:SILICON,FET,N-CHANNEL,2N4416
Q382	151-1025-00	TRANSISTOR:SILICON,FET,N-CHANNEL,2N4416
Q392	151-1025-00	TRANSISTOR:SILICON,FET,N-CHANNEL,2N4416
R262	321-0257-00	RES.,FXD,FILM:4.64K OHM,1%,0.125W
R263	321-0181-00	RES.,FXD,FILM:750 OHM,1%,0.125W
R268	321-0295-00	RES.,FXD,FILM:11.5K OHM,1%,0.125W
R272	321-0257-00	RES.,FXD,FILM:4.64K OHM,1%,0.125W
R273	311-1566-00	RES.,VAR,NONWIR:200 OHM,20%,0.50W
R278	321-0295-00	RES.,FXD,FILM:11.5K OHM,1%,0.125W
R279	321-0661-00	RES.,FXD,FILM:600 OHM,1%,0.125W
R284	321-0130-00	RES.,FXD,FILM:221 OHM,1%,0.125W
R294	321-0130-00	RES.,FXD,FILM:221 OHM,1%,0.125W
R362	321-0257-00	RES.,FXD,FILM:4.64K OHM,1%,0.125W
R363	321-0181-00	RES.,FXD,FILM:750 OHM,1%,0.125W
R368	321-0295-00	RES.,FXD,FILM:11.5K OHM,1%,0.125W
R372	321-0257-00	RES.,FXD,FILM:4.64K OHM,1%,0.125W
R373	311-1566-00	RES.,VAR,NONWIR:200 OHM,20%,0.50W
R378	321-0295-00	RES.,FXD,FILM:11.5K OHM,1%,0.125W
R379	321-0661-00	RES.,FXD,FILM:600 OHM,1%,0.125W
R384	321-0130-00	RES.,FXD,FILM:221 OHM,1%,0.125W

CHANGE	DESCRIPTION	
CHANGE TO:		
R387	321-0332-00	RES., FXD, FILM: 28K OHM, 1%, 0.125W
R389	321-0338-00	RES., FXD, FILM: 32.4K OHM, 1%, 0.125W
R394	321-0130-00	RES., FXD, FILM: 221 OHM, 1%, 0.125W
ADD:		
R261	321-0260-00	RES., FXD, FILM: 4.99K OHM, 1%, 0.125W
R361	321-0260-00	RES., FXD, FILM: 4.99K OHM, 1%, 0.125W
DIAGRAM  OUTPUT AMPLIFIERS		
R261 is added in parallel with R264.		
R361 is added in parallel with R364.		